

AGENDA

SPECIAL SCHOOL BOARD MEETING

GADSDEN COUNTY SCHOOL BOARD
MAX D. WALKER ADMINISTRATION BUILDING
35 MARTIN LUTHER KING, JR. BLVD.
QUINCY, FLORIDA

October 10, 2023

5:00 P.M.

THIS MEETING IS OPEN TO THE PUBLIC

1. CALL TO ORDER
2. OPENING PRAYER
3. PLEDGE OF ALLEGIANCE

ITEMS FOR CONSENT

4. AGREEMENT/CONTRACT/PROJECT APPLICATIONS

- a. Purchase Order Request for Pro Playgrounds – **SEE PAGE #3**

Fund Source: ESSER 3

Amount: Bold Step Infant Care - \$103,999.00
 Chattahoochee Elementary - \$179,999.00
 Gadsden Elementary Magnet - \$169,999.00
 George Munroe Elementary - \$195,999.00
 Greensboro Elementary - \$193,999.00
 Havana Magnet - \$199,999.00
 Stewart Street Elementary - \$203,999.00

ACTION REQUESTED: The Superintendent recommends approval.

- b. Purchase Order Request for Shaw Integrated Solutions – **SEE PAGE #107**

Fund Source: ESSER 2 Lump Sum

Amount: Gadsden County High School - \$44,072.00
 Building #7 at 655 South Stewart Street - \$25,941.16

ACTION REQUESTED: The Superintendent recommends approval.

- c. Contractual Agreement between Gadsden County District Schools and Ethica, LLC
SEE PAGE #148

Fund Source: Title I

Amount: \$21,000.00

ACTION REQUESTED: The Superintendent recommends approval.

5. EDUCATIONAL ISSUES

- a. Gadsden County High School Agriculture Students Field Trip Request
SEE PAGE #157

Fund Source: N/A

Amount: N/A

ACTION REQUESTED: The Superintendent recommends approval.

- b. 2023 - 2024 Code of Student Conduct – **SEE PAGE #165**

Fund Source: N/A

Amount: N/A

ACTION REQUESTED: The Superintendent recommends approval.

ITEMS FOR DISCUSSION

6. ESSER 2 & 3 Funding Update
7. Educational Items by the Superintendent
8. School Board Requests and Concerns
9. Adjournment

SUMMARY SHEET

RECOMMENDATION TO SUPERINTENDENT FOR SCHOOL BOARD AGENDA

AGENDA ITEM NO. 4a

DATE OF SCHOOL BOARD MEETING: October 10, 2023

TITLE OF AGENDA ITEM: Purchase Order Request for Pro Playgrounds

DIVISION: Facilities

 This is a CONTINUATION of a current project, grant, etc.

PURPOSE AND SUMMARY OF ITEM: This request is for School Board approval of seven purchase orders to be issued to Pro Playgrounds. This would be for the removal of existing playground equipment and the purchase and installation of new playground equipment. The locations are Bold Step Infant Care, Chattahoochee Elementary, Gadsden Elementary Magnet, George Munroe Elementary, Greensboro Elementary, Havana Magnet and Stewart Street Elementary. Attached are copies of the seven quotes.

FUND SOURCE: ESSR 3

AMOUNT:
Bold Step Infant Care - \$103,999.00
Chattahoochee Elementary - \$179,999.00
Gadsden Elementary Magnet - \$169,999.00
George Munroe Elementary - \$195,999.00
Greensboro Elementary - \$193,999.00
Havana Magnet - \$199,999.00
Stewart Street Elementary - \$203,999.00

PREPARED BY: Brenton Hudson *BEH*

POSITION: Director of Facilities

INTERNAL INSTRUCTIONS TO BE COMPLETED BY PREPARER

1 Number of ORIGINAL SIGNATURES NEEDED by preparer.

SUPERINTENDENT'S SIGNATURE: page(s) numbered 1

CHAIRMAN'S SIGNATURE: page(s) numbered NA

REVIEWED BY: 

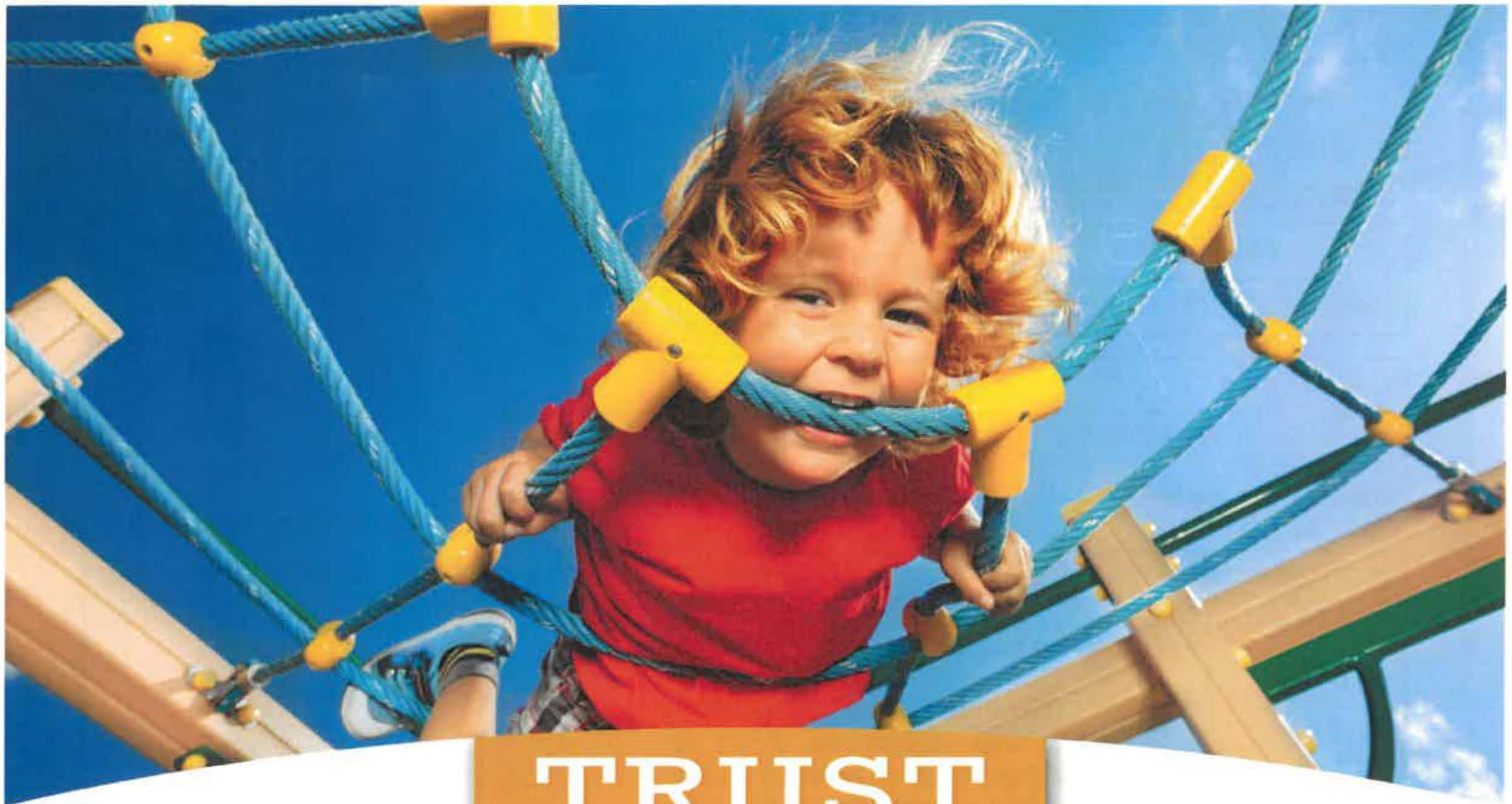

TRUST — the — EXPERTS

For over a decade, our customers have entrusted us to provide safe and affordable playground and recreational equipment. Our team of Certified General Contractors and Playground Safety Inspectors will insure that your project is completed to perfection, providing truly turnkey service, with every step of the process from planning and budgeting, through the installation being handled under one roof.



1-800-573-7529 | www.proplaygrounds.com



Pro Playgrounds
8490 Cabin Hill Road
Tallahassee, FL 32311

Quote

Date	Estimate #
9/12/2023	21968

Project Name
Gadsden County SD - Carter Par...



Customer / Bill To
Gadsden County School District Tammy McGriff 35 Martin Luther King Blvd Quincy, FL 32351

Ship To
Carter Parramore Academy Johnny Riley 631 S Stewart St. Quincy, FL 32351



WE WILL BEAT ANY PRICE BY 5%!

Item	Description	Qty	Cost	Total:
	<p>Furnish labor and materials to:</p> <p>**KINDERGARTEN/PRE-K PLAYGROUND SCOPE OF WORK** Age range - 2-5 years old</p> <ol style="list-style-type: none"> 1.) Install 1x Ketchum Playground System 2.) Install 1x 1 Bay 2 Cantilever Swing Set 2.) Remove 1,596 square feet of sod 3.) Install 33 tons of aggregate rock subbase at a 4" depth 3.) Install 572 square feet of poured in place rubber surfacing with a 1.5" SBR thickness (4' fall height compliance) with a 50% color tpv and 50% black tpv .5" granule mix (2" total rubber thickness) over an aggregate rock subbase *UNDER PLAYGROUND EQUIPMENT* 4.) Install 1,024 square feet of poured in place rubber surfacing with a 3" SBR thickness (8' fall height compliance) with a 50% color tpv and 50% black tpv .5" granule mix (3.5" total rubber thickness) over an aggregate rock subbase *UNDER SWING SET* 4.) Install 1x 30'x24'x10' Hip Shade with Glide (inground mount) <p>**NOTES**</p>			

AGREED AND ACCEPTED:
If the above total price, scope of work, specifications, terms and conditions are acceptable, sign below indicating your acceptance and authorization for Pro Playgrounds to proceed with the work and/or sales transaction described in this quotation. Upon signature and payment in accordance with this quote, Pro Playgrounds will proceed with the work and/or sales transaction.

Signature Name / Title Date

Subtotal:
Sales Tax: (7.5%)
Total:

Terms and Conditions - Price valid for 30 days and subject to change. 1. If installation is not included with your purchase, client will be responsible for coordinating, receiving and unloading of all goods, delivery drivers will not help unload goods. 2. Client will be responsible to inspect goods for defect, damage or missing parts, any deficiency or missing parts must be noted on delivery slip. 3. Client will be responsible for costs due to cancelled or missed delivery appointments. 4. Client has reviewed all items, colors and descriptions on this quote for accuracy and correctness. 5. If quote includes installation of goods, the installation is subject to the terms and conditions of Pro Playgrounds "Standard Installation Agreement" a copy of which may be obtained from your Sales Representative.



Pro Playgrounds
8490 Cabin Hill Road
Tallahassee, FL 32311

Quote

Project Name
Gadsden County SD - Carter Par...



Date	Estimate #
9/12/2023	21968



Customer / Bill To
Gadsden County School District Tammy McGriff 35 Martin Luther King Blvd Quincy, FL 32351

Ship To
Carter Parramore Academy Johnny Riley 631 S Stewart St. Quincy, FL 32351

WE WILL BEAT ANY PRICE BY 5%!

Item	Description	Qty	Cost	Total:
	-Surfacing area is 26'x22' for Playground Equipment -Surfacing area is 32'x32 for swing set -Total square footage is 1,596 square feet **INFANT PLAYGROUND SCOPE OF WORK** Age range - 6-23 months 1.) Install 1x Stamford Playground System 3.) Remove 288 square feet of sod 4.) Install 6 tons of aggregate rock subbase at a 4" depth 5.) Install 288 square feet of poured in place rubber surfacing at a 1.5" SBR thickness (4' fall height compliance) with a 50% color tpv and 50% black tpv .5" granule mix (2" total rubber thickness) over an aggregate rock subbase 6.) Install 1x 20'x18'x10' Hip Shade with Glide (inground mount) **NOTES** -Surfacing area is 18'x16' -Total square footage is 288 square feet **GENERAL SCOPE OF WORK** 1.) Assemble 2x Metal Outdoor Bench 2.) Assemble 1x 6' Regal ADA Picnic Table			

AGREED AND ACCEPTED:
If the above total price, scope of work, specifications, terms and conditions are acceptable, sign below indicating your acceptance and authorization for Pro Playgrounds to proceed with the work and/or sales transaction described in this quotation. Upon signature and payment in accordance with this quote, Pro Playgrounds will proceed with the work and/or sales transaction.

_____/_____/_____
Signature Name / Title Date

Subtotal:
Sales Tax: (7.5%)
Total:

Terms and Conditions - Price valid for 30 days and subject to change. 1. If installation is not included with your purchase, client will be responsible for coordinating, receiving and unloading of all goods, delivery drivers will not help unload goods. 2. Client will be responsible to inspect goods for defect, damage or missing parts, any deficiency or missing parts must be noted on delivery slip. 3. Client will be responsible for costs due to cancelled or missed delivery appointments. 4. Client has reviewed all items, colors and descriptions on this quote for accuracy and correctness. 5. If quote includes installation of goods, the installation is subject to the terms and conditions of Pro Playgrounds "Standard Installation Agreement" a copy of which may be obtained from your Sales Representative.



Pro Playgrounds
 8490 Cabin Hill Road
 Tallahassee, FL 32311

Quote

Date	Estimate #
9/12/2023	21968

Project Name
Gadsden County SD - Carter Par...



Customer / Bill To
Gadsden County School District Tammy McGriff 35 Martin Luther King Blvd Quincy, FL 32351

Ship To
Carter Parramore Academy Johnny Riley 631 S Stewart St. Quincy, FL 32351

WE WILL BEAT ANY PRICE BY 5%!

Item	Description	Qty	Cost	Total:
	3.) Assemble 1x 6' Regal Picnic Table			
	NOTES -There is no equipment removal at this site. -Total square footage for both playground areas is 1,884 square feet			
	KINDERGARTEN/PRE-K PLAYGROUND EQUIPMENT			
23-PKP260	Ketchum - child capacity is 14	1	9,153.00	9,153.00
QS-23-PSW120...	1 Bay 2 Cantilevers - Frame w/ Hangers, 1 Bay Belt Seat Package, 1 Bay Bucket Package	1	1,699.00	1,699.00
	INFANT PLAYGROUND			
23-PKP177	Stamford - child capacity is 34	1	12,811.00	12,811.00
Shipping	Combined Shipping and Freight Charges	1	3,125.00	3,125.00
	SHADE/SHELTER			
22-RD243010IG	10' Height -INGROUND - WITH GLIDE - RECTANGLE	1	9,899.00	9,899.00
22-RD182010IG	10' Height -INGROUND - WITH GLIDE - RECTANGLE	1	6,599.00	6,599.00
Shipping	Combined Shipping and Freight Charges	1	1,412.56	1,412.56
	SITE AMMENITIES			

AGREED AND ACCEPTED:
 If the above total price, scope of work, specifications, terms and conditions are acceptable, sign below indicating your acceptance and authorization for Pro Playgrounds to proceed with the work and/or sales transaction described in this quotation. Upon signature and payment in accordance with this quote, Pro Playgrounds will proceed with the work and/or sales transaction.

 Signature Name / Title Date

Subtotal:
Sales Tax: (7.5%)
Total:

Terms and Conditions - Price valid for 30 days and subject to change. 1. If installation is not included with your purchase, client will be responsible for coordinating, receiving and unloading of all goods, delivery drivers will not help unload goods. 2. Client will be responsible to inspect goods for defect, damage or missing parts, any deficiency or missing parts must be noted on delivery slip. 3. Client will be responsible for costs due to cancelled or missed delivery appointments. 4. Client has reviewed all items, colors and descriptions on this quote for accuracy and correctness. 5. If quote includes installation of goods, the installation is subject to the terms and conditions of Pro Playgrounds "Standard Installation Agreement" a copy of which may be obtained from your Sales Representative.



The Play & Recreation Experts

Pro Playgrounds
8490 Cabin Hill Road
Tallahassee, FL 32311

Quote

Date	Estimate #
9/12/2023	21968



WE WILL BEAT ANY PRICE BY 5%!

Project Name
Gadsden County SD - Carter Par...



Customer / Bill To
Gadsden County School District Tammy McGriff 35 Martin Luther King Blvd Quincy, FL 32351

Ship To
Carter Parramore Academy Johnny Riley 631 S Stewart St. Quincy, FL 32351

Item	Description	Qty	Cost	Total:
22-B6WBULP	6' UltraLeisureStandard Bench with Back, Portable	2	599.00	1,198.00
22-T6UL	6' UltraLeisureRectangular Portable Table	1	1,099.00	1,099.00
22-T6ULHDCP	6' UltraLeisureAccessible Rectangular Portable Table*	1	1,199.00	1,199.00
Shipping	Combined Shipping and Freight Charges	1	1,009.60	1,009.60
SURFACING MATERIALS				
TPV-BT	Premium 1350 Black Granules T	40	37.881	1,515.24
TPV-CT	Color TPV Granules T	40	106.1145	4,244.58
SBRT	SBR Buffings T	159	30.95239	4,921.43
ARODT	PremArc Aromatic T Binder Drum	4	1,741.5725	6,966.29
AROPT	PremArc Aromatic Binder-T Pail	4	188.50	754.00
Shipping	Combined Shipping and Freight Charges	1	2,000.00	2,000.00
RAW MATERIALS				
AGG	Locally sourced crushed aggregate base materials (ABC Crush and Run Typical)	39	45.00	1,755.00
FBLOCK	Footer Blocks	62	3.75	232.50
CC80	Concrete for Anchoring - Delivered Cost	68	8.40	571.20
RBAR5	No. 5 Rebar	390	1.25	487.50
RMC	Ready Mix Concrete 2500 PSI MIN	9	200.00	1,800.00
RENTALS, LABOR, AND INSTALLATION				
22-Rentals	Rentals Necessary for Installation	1	7,723.16	7,723.16
LBR	Surfacing Removal Labor and Installation	1	5,250.00	5,250.00

AGREED AND ACCEPTED:
If the above total price, scope of work, specifications, terms and conditions are acceptable, sign below indicating your acceptance and authorization for Pro Playgrounds to proceed with the work and/or sales transaction described in this quotation. Upon signature and payment in accordance with this quote, Pro Playgrounds will proceed with the work and/or sales transaction.

_____/_____/_____
Signature Name / Title Date

Subtotal:
Sales Tax: (7.5%)
Total:

Terms and Conditions - Price valid for 30 days and subject to change. 1. If installation is not included with your purchase, client will be responsible for coordinating, receiving and unloading of all goods, delivery drivers will not help unload goods. 2. Client will be responsible to inspect goods for defect, damage or missing parts, any deficiency or missing parts must be noted on delivery slip. 3. Client will be responsible for costs due to cancelled or missed delivery appointments. 4. Client has reviewed all items, colors and descriptions on this quote for accuracy and correctness. 5. If quote includes installation of goods, the installation is subject to the terms and conditions of Pro Playgrounds "Standard Installation Agreement" a copy of which may be obtained from your Sales Representative.



Pro Playgrounds
8490 Cabin Hill Road
Tallahassee, FL 32311

Quote

Date	Estimate #
9/12/2023	21968

Project Name
Gadsden County SD - Carter Par...



Customer / Bill To
Gadsden County School District Tammy McGriff 35 Martin Luther King Blvd Quincy, FL 32351

Ship To
Carter Parramore Academy Johnny Riley 631 S Stewart St. Quincy, FL 32351

WE WILL BEAT ANY PRICE BY 5%!

Item	Description	Qty	Cost	Total:
LBR	Pour in Place Rubber Surfacing Labor and Installation	1	6,440.53	6,440.53
LBR	Labor and Installation Equipment	1	22,374.10	22,374.10
DSC	Discount - Per Contract Equipment		-6,392.60	-6,392.60
DSC	Discount - Per Contract Surfacing		-1,840.15	-1,840.15
DSC	Discount - Additional		-4,007.94	-4,007.94

AGREED AND ACCEPTED:

If the above total price, scope of work, specifications, terms and conditions are acceptable, sign below indicating your acceptance and authorization for Pro Playgrounds to proceed with the work and/or sales transaction described in this quotation. Upon signature and payment in accordance with this quote, Pro Playgrounds will proceed with the work and/or sales transaction.

Signature _____	Name / Title _____	Date _____
-----------------	--------------------	------------

Subtotal: \$103,999.00

Sales Tax: (7.5%) \$0.00

Total: \$103,999.00

Terms and Conditions - Price valid for 30 days and subject to change. 1. If installation is not included with your purchase, client will be responsible for coordinating, receiving and unloading of all goods, delivery drivers will not help unload goods. 2. Client will be responsible to inspect goods for defect, damage or missing parts, any deficiency or missing parts must be noted on delivery slip. 3. Client will be responsible for costs due to cancelled or missed delivery appointments. 4. Client has reviewed all items, colors and descriptions on this quote for accuracy and correctness. 5. If quote includes installation of goods, the installation is subject to the terms and conditions of Pro Playgrounds "Standard Installation Agreement" a copy of which may be obtained from your Sales Representative.











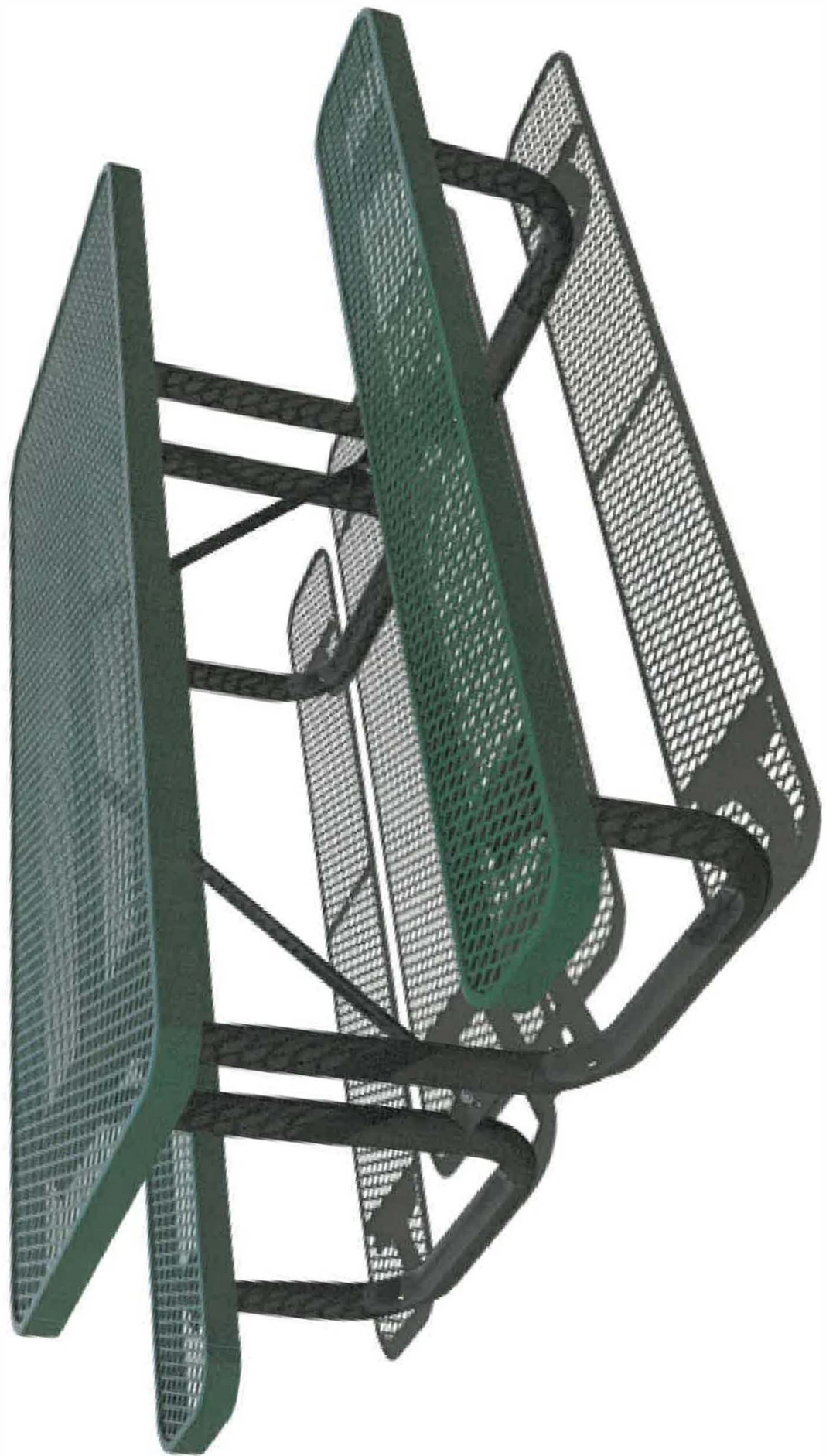

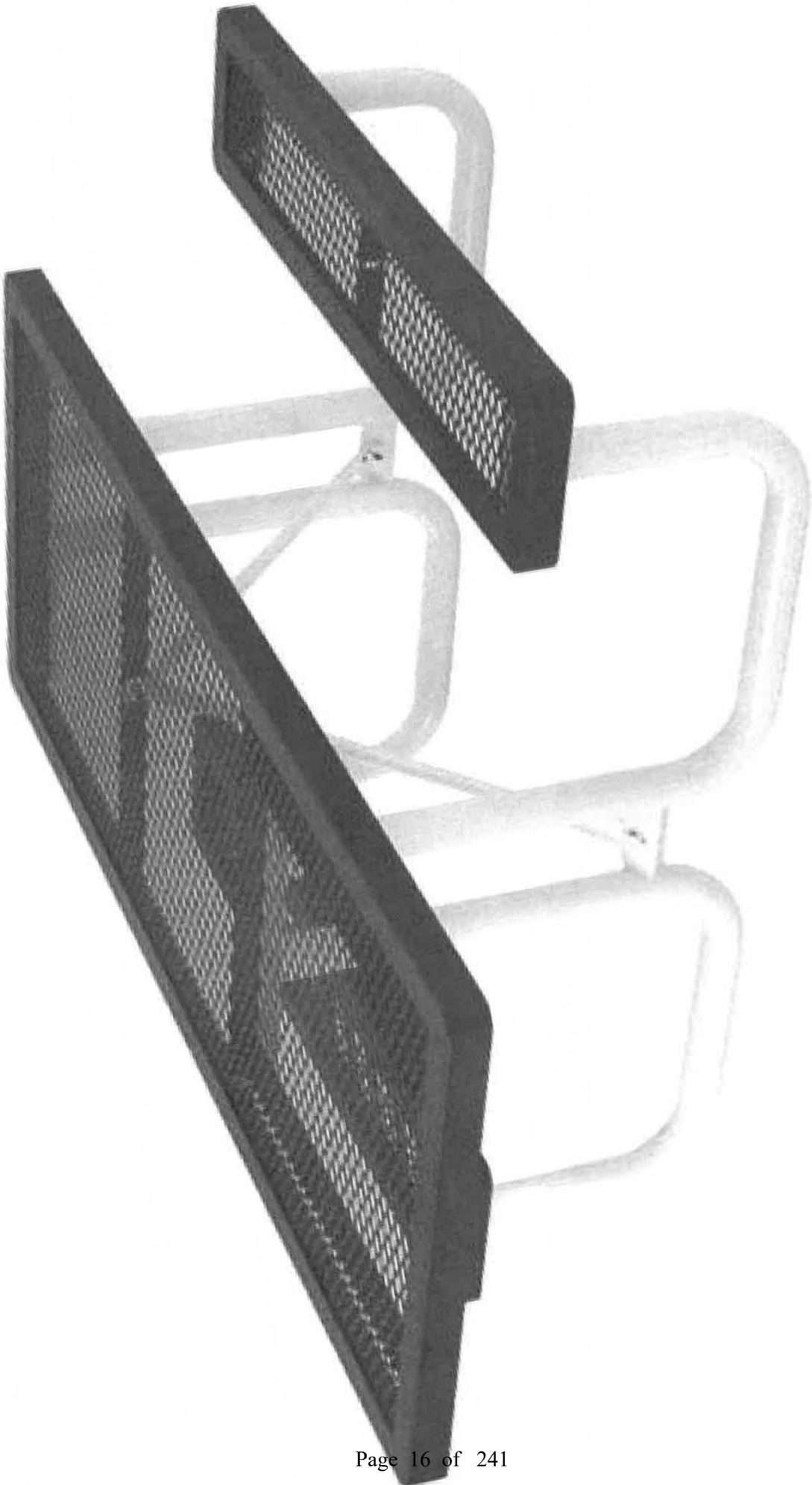

Hip Shade

Length	20'	Width	18'	Entry Height	10'
Peak Height	13.33'	Elbow	Glide	Column Mount	Embedded
Column Size	Ø5.0" 7-Ga	Rafter Size	Ø2.875" 12-Ga	Ridge Size	Ø2.875" 12-Ga
Column Length	13'	Rafter Length	11.73'	Ridge Length	6.5'
Dome Qty.	1	Column Qty.	4		

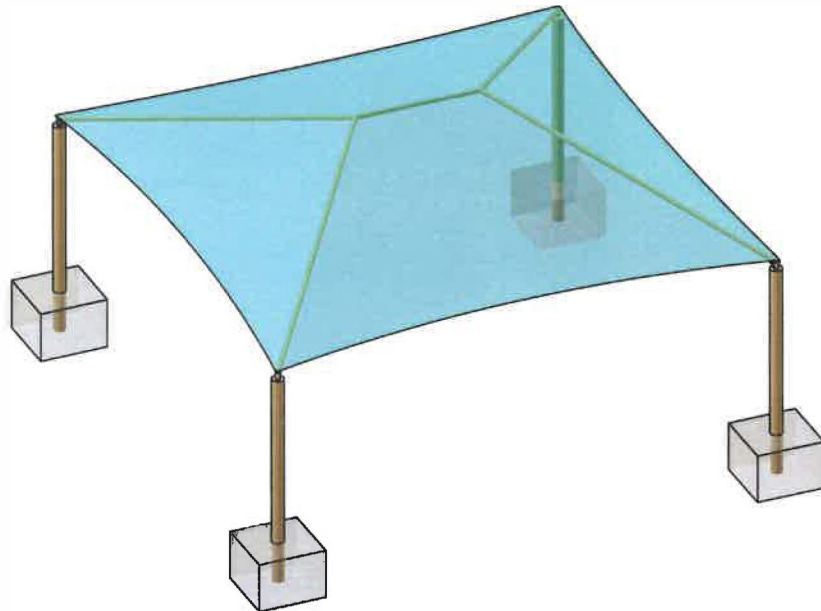

Square Footing		
Column	Length & Width	Depth
Single Cap	2.49	3
Double Cap	N/A	3

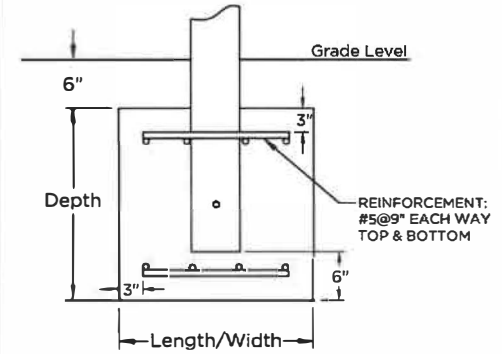

Auger Footing		
Diameter	Single Cap Depth	Double Cap Depth
1'-6"		
2'-0"	4.72	N/A
2'-6"	3.02	N/A
3'-0"	Out of range	N/A

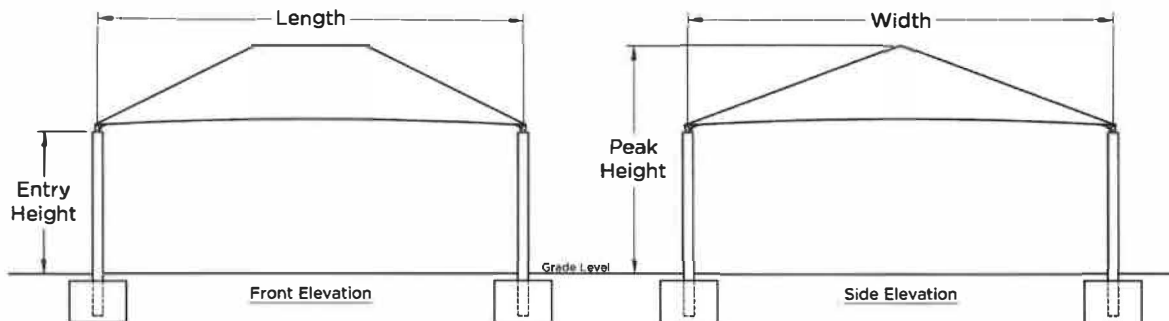
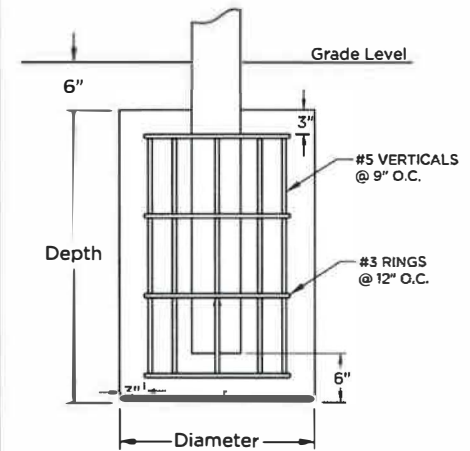

SuperiorShade

QUOTE

SHADE SIZE

20 X 18

SHADE STYLE

Hip Shade

These drawings are for reference only and should not be used as construction details. They show the general character and rough dimensions of the structural features. Exact spans, fasteners, materials, and foundations can be determined by a licensed professional engineer upon request. Estimated footing size above is based on 1,500 PSF soil bearing pressure.

Hip Shade

Length	30'	Width	24'	Entry Height	10'
Peak Height	14.85'	Elbow	Glide	Column Mount	Embedded
Column Size	Ø5.5" Sch-40	Rafter Size	Ø3.5" 11-Ga	Ridge Size	Ø3.5" 11-Ga
Column Length	13'	Rafter Length	17.06'	Ridge Length	7.76'
Dome Qty.	1	Column Qty.	4		

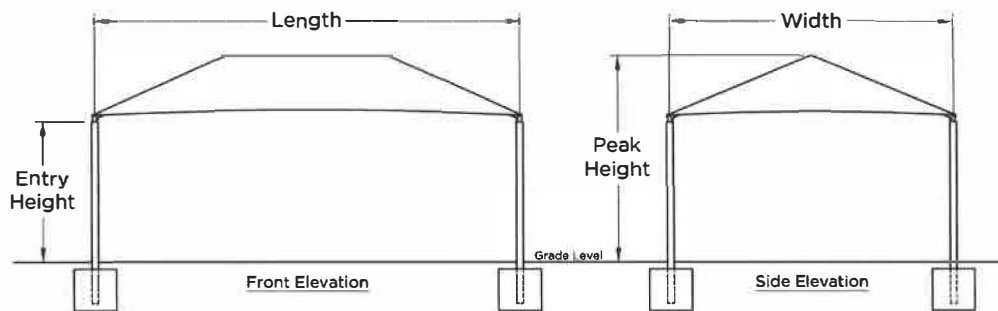
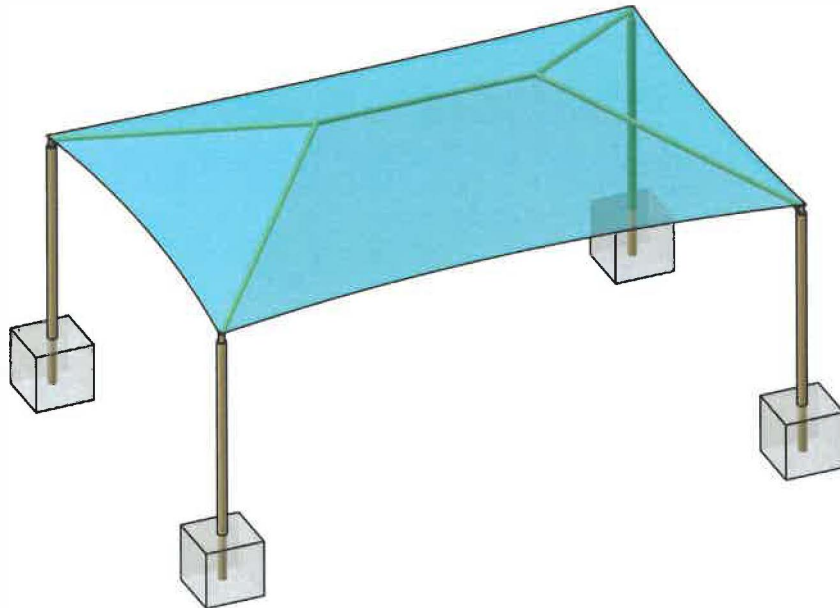

Square Footing		
Column	Length & Width	Depth
Single Cap	3.52	3
Double Cap	N/A	3

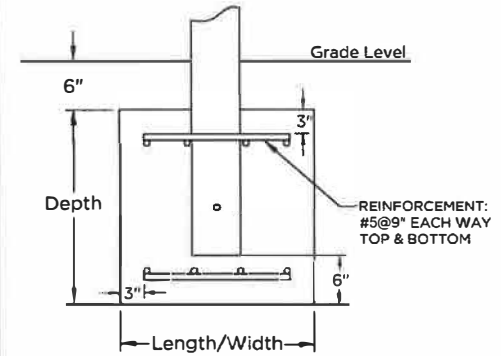

Auger Footing		
Diameter	Single Cap Depth	Double Cap Depth
1'-6"		
2'-0"	Out of range	N/A
2'-6"	Out of range	N/A
3'-0"	4.2	N/A

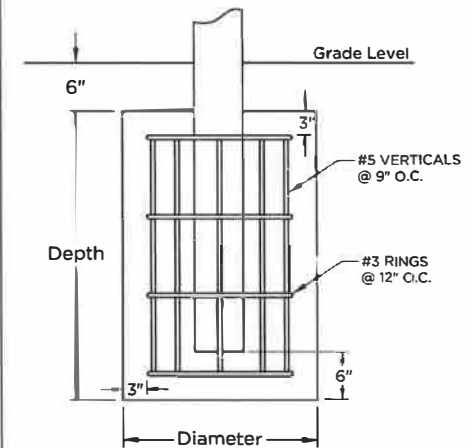

SuperiorShade

QUOTE

SHADE SIZE

30 X 24

SHADE STYLE

Hip Shade

These drawings are for reference only and should not be used as construction details. They show the general character and rough dimensions of the structural features. Exact spans, fasteners, materials, and foundations can be determined by a licensed professional engineer upon request. Estimated footing size above is based on 1,500 PSF soil bearing pressure.

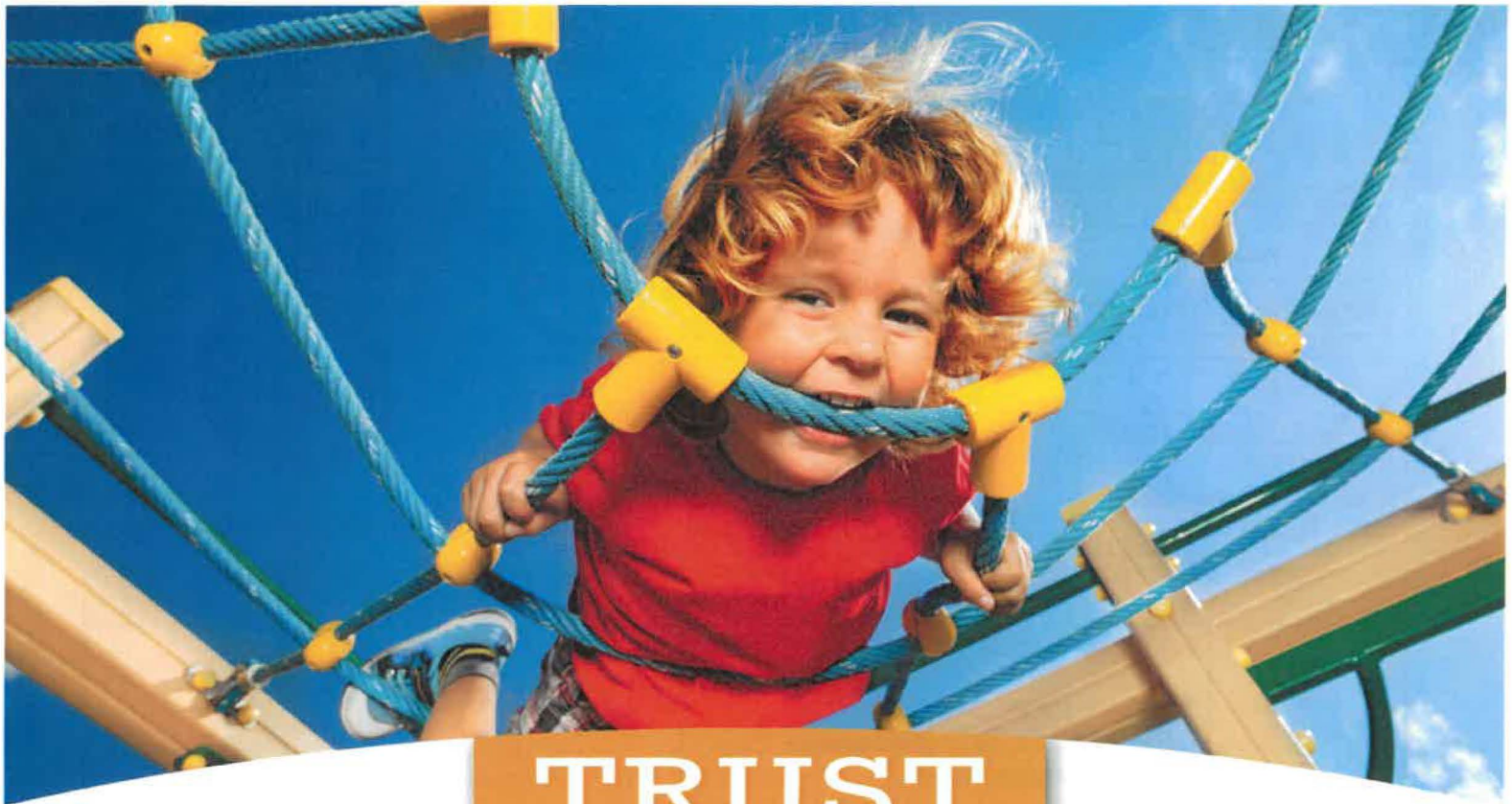

TRUST — the — EXPERTS

For over a decade, our customers have entrusted us to provide safe and affordable playground and recreational equipment. Our team of Certified General Contractors and Playground Safety Inspectors will insure that your project is completed to perfection, providing truly turnkey service, with every step of the process from planning and budgeting, through the installation being handled under one roof.



1-800-573-7529 | www.proplaygrounds.com



Pro Playgrounds
 8490 Cabin Hill Road
 Tallahassee, FL 32311

Quote

Date	Estimate #
9/1/2023	21794

Project Name
Gadsden County SD - Chattahoo...



Customer / Bill To
Gadsden County School District Tammy McGriff 35 Martin Luther King Blvd Quincy, FL 32351

Ship To
Chattahoochee Elementary Johnny Riley 335 Maple Street Chattahoochee, FL 32324



WE WILL BEAT ANY PRICE BY 5%!

Item	Description	Qty	Cost	Total:
	Furnish labor and materials to: **GENERAL SCOPE OF WORK** 1.) Remove existing playground equipment a.) 2 deck layground system b.) 1 climber c.) 1 T-cantilever swing b.) 1695 square feet of wood mulch and borders 2.) Remove 800 square foot concrete path 3.) Remove Existing Safety Surfacing 4.) Assemble 4x Portable Metal Outdoor Bench 5.) Assemble 1x Portable Picnic Table 6.) Assemble 1x Portable ADA Picnic Table **NOTES** -Total Square footage is 2,585 **ELEMENTARY PLAYGROUND SCOPE OF WORK** 1.) Install 1x Barrington Ridge Play System 2.) Install 1x Camp Walden Interactive Panels 3.) Install 1x 1 Bay 2 Cantilever Swing Set 4.) Install 37 tons of aggregate rock subbase 5.) Install 989 square feet of poured in place rubber surfacing with a 2" SBR thickness (6' fall height)			

AGREED AND ACCEPTED:
 If the above total price, scope of work, specifications, terms and conditions are acceptable, sign below indicating your acceptance and authorization for Pro Playgrounds to proceed with the work and/or sales transaction described in this quotation. Upon signature and payment in accordance with this quote, Pro Playgrounds will proceed with the work and/or sales transaction.

 Signature Name / Title Date

Subtotal:
Sales Tax: (7.5%)
Total:

Terms and Conditions - Price valid for 30 days and subject to change. 1. If installation is not included with your purchase, client will be responsible for coordinating, receiving and unloading of all goods, delivery drivers will not help unload goods. 2. Client will be responsible to inspect goods for defect, damage or missing parts, any deficiency or missing parts must be noted on delivery slip. 3. Client will be responsible for costs due to cancelled or missed delivery appointments. 4. Client has reviewed all items, colors and descriptions on this quote for accuracy and correctness. 5. If quote includes installation of goods, the installation is subject to the terms and conditions of Pro Playgrounds "Standard Installation Agreement" a copy of which may be obtained from your Sales Representative.



Pro Playgrounds
8490 Cabin Hill Road
Tallahassee, FL 32311

Quote

Date	Estimate #
9/1/2023	21794

Project Name
Gadsden County SD - Chattahoo...



Customer / Bill To
Gadsden County School District
Tammy McGriff
35 Martin Luther King Blvd
Quincy, FL 32351

Ship To
Chattahoochee Elementary
Johnny Riley
335 Maple Street
Chattahoochee, FL 32324

WE WILL BEAT ANY PRICE BY 5%!

Item	Description	Qty	Cost	Total:
	<p>compliance) with a 50% color tpv and 50% black tpv .5" granule mix (2.5" total rubber thickness) over an aggregate base</p> <p>6.) Install 1,024 square feet of poured in place rubber surfacing with a 3" SBR thickness (8' fall height compliance) with a 50% color tpv and 50% black tpv .5" granule mix (3.5" total rubber thickness) over an aggregate base</p> <p>7.) Install 1x 45'x28'x15' Standard Hip Shade (on base plates)</p> <p>**NOTES**</p> <p>-Surfacing area is 43'x23' - Playground -Surfacing area is 32'x32' - Swingset -Total Square footage is 2,013</p> <p>**KINDERGARTEN/PRE-K PLAYGROUND SCOPE OF WORK**</p> <p>1.) Install 1x Ketchum Playground System 2.) Install 10 tons of aggregate rock subbase at a 4" depth 3.) Install 572 square feet of poured in place rubber surfacing with a 1.5" SBR thickness (4' fall height compliance) with a 50% color tpv and 50% black tpv .5" granule mix (2" total rubber thickness) over an</p>			

AGREED AND ACCEPTED:
If the above total price, scope of work, specifications, terms and conditions are acceptable, sign below indicating your acceptance and authorization for Pro Playgrounds to proceed with the work and/or sales transaction described in this quotation. Upon signature and payment in accordance with this quote, Pro Playgrounds will proceed with the work and/or sales transaction.

_____/_____/_____
Signature Name / Title Date

Subtotal:
Sales Tax: (7.5%)
Total:

Terms and Conditions - Price valid for 30 days and subject to change. 1. If installation is not included with your purchase, client will be responsible for coordinating, receiving and unloading of all goods, delivery drivers will not help unload goods. 2. Client will be responsible to inspect goods for defect, damage or missing parts, any deficiency or missing parts must be noted on delivery slip. 3. Client will be responsible for costs due to cancelled or missed delivery appointments. 4. Client has reviewed all items, colors and descriptions on this quote for accuracy and correctness. 5. If quote includes installation of goods, the installation is subject to the terms and conditions of Pro Playgrounds "Standard Installation Agreement" a copy of which may be obtained from your Sales Representative.



Pro Playgrounds
8490 Cabin Hill Road
Tallahassee, FL 32311

Quote

Date	Estimate #
9/1/2023	21794

Project Name
Gadsden County SD - Chattahoo...



Customer / Bill To
Gadsden County School District
Tammy McGriff
35 Martin Luther King Blvd
Quincy, FL 32351

Ship To
Chattahoochee Elementary
Johnny Riley
335 Maple Street
Chattahoochee, FL 32324



WE WILL BEAT ANY PRICE BY 5%!

Item	Description	Qty	Cost	Total:
	aggregate rock base. 4.) Install 1x 30'x24'x10' Hip Shade with Glide (inground mount)			
	NOTES -Surfacing area is 26'x22' -Square footage is 572			
	ELEMENTARY PLAY EQUIPMENT			
23-PMF035	Barrington Ridge	1	36,839.00	36,839.00
QS-23-PKP025P	Camp Walden - Primary	1	5,913.00	5,913.00
QS-23-PSW120...	1 Bay 2 Cantilevers - Frame w/ Hangers, 1 Bay Belt Seat Package, 1 Bay Bucket Package	1	1,699.00	1,699.00
	KINDERGARTEN/PRE-K PLAYGROUND			
23-PKP260	Ketchum	1	9,153.00	9,153.00
Shipping	Combined Shipping and Freight Charges	1	3,600.00	3,600.00
	SHADE/SHELTER			
CSSD	Custom Shade Design - 45'x28'x15' Standard Hip Shade (on base plates)	1	21,199.00	21,199.00
22-RD243010IG	30'x24'x10' Height -INGROUND - WITH GLIDE - RECTANGLE	1	9,799.00	9,799.00
Shipping	Combined Shipping and Freight Charges	1	1,188.55	1,188.55

AGREED AND ACCEPTED:
If the above total price, scope of work, specifications, terms and conditions are acceptable, sign below indicating your acceptance and authorization for Pro Playgrounds to proceed with the work and/or sales transaction described in this quotation. Upon signature and payment in accordance with this quote, Pro Playgrounds will proceed with the work and/or sales transaction.

Signature Name / Title Date

Subtotal:
Sales Tax: (7.5%)
Total:

Terms and Conditions - Price valid for 30 days and subject to change. 1. If installation is not included with your purchase, client will be responsible for coordinating, receiving and unloading of all goods, delivery drivers will not help unload goods. 2. Client will be responsible to inspect goods for defect, damage or missing parts, any deficiency or missing parts must be noted on delivery slip. 3. Client will be responsible for costs due to cancelled or missed delivery appointments. 4. Client has reviewed all items, colors and descriptions on this quote for accuracy and correctness. 5. If quote includes installation of goods, the installation is subject to the terms and conditions of Pro Playgrounds "Standard Installation Agreement" a copy of which may be obtained from your Sales Representative.



The Play & Recreation Experts

Pro Playgrounds
8490 Cabin Hill Road
Tallahassee, FL 32311

Quote

Date	Estimate #
9/1/2023	21794

Project Name
Gadsden County SD - Chattahoo...



Customer / Bill To
Gadsden County School District Tammy McGriff 35 Martin Luther King Blvd Quincy, FL 32351

Ship To
Chattahoochee Elementary Johnny Riley 335 Maple Street Chattahoochee, FL 32324

WE WILL BEAT ANY PRICE BY 5%!

Item	Description	Qty	Cost	Total:
SITE AMMENITIES				
22-B6WBULP	6' UltraLeisureStandard Bench with Back, Portable	4	599.00	2,396.00
22-T6UL	6' UltraLeisureRectangular Portable Table	1	1,099.00	1,099.00
22-T6ULHDCP	6' UltraLeisureAccessible Rectangular Portable Table*	1	1,199.00	1,199.00
Shipping	Combined Shipping and Freight Charges	1	1,366.60	1,366.60
SURFACING MATERIALS				
TPV-BT	Premium 1350 Black Granules T	55	37.88091	2,083.45
TPV-CT	Color TPV Granules T	55	107.30018	5,901.51
SBRT	SBR Buffings T	268	30.95239	8,295.24
ARODT	PremArc Aromatic T Binder Drum	6	1,741.57167	10,449.43
AROPT	PremArc Aromatic Binder-T Pail	8	188.50	1,508.00
Shipping	Combined Shipping and Freight Charges	1	2,520.00	2,520.00
RAW MATERIALS				
AGG	Locally sourced crushed aggregate base materials (ABC Crush and Run Typical)	47	45.00	2,115.00
FBLOCK	Footer Blocks	80	3.75	300.00
CC80	Concrete for Anchoring - Delivered Cost	104	8.40	873.60
RBAR5	No. 5 Rebar	950	1.25	1,187.50
RMC	Ready Mix Concrete 2500 PSI MIN	21	200.00	4,200.00
RENTALS, LABOR, AND INSTALLATION				
22-Rentals	Rentals Necessary for Installation	1	11,522.29	11,522.29

AGREED AND ACCEPTED:
If the above total price, scope of work, specifications, terms and conditions are acceptable, sign below indicating your acceptance and authorization for Pro Playgrounds to proceed with the work and/or sales transaction described in this quotation. Upon signature and payment in accordance with this quote, Pro Playgrounds will proceed with the work and/or sales transaction.

_____/_____/_____
Signature Name / Title Date

Subtotal:
Sales Tax: (7.5%)
Total:

Terms and Conditions - Price valid for 30 days and subject to change. 1. If installation is not included with your purchase, client will be responsible for coordinating, receiving and unloading of all goods, delivery drivers will not help unload goods. 2. Client will be responsible to inspect goods for defect, damage or missing parts, any deficiency or missing parts must be noted on delivery slip. 3. Client will be responsible for costs due to cancelled or missed delivery appointments. 4. Client has reviewed all items, colors and descriptions on this quote for accuracy and correctness. 5. If quote includes installation of goods, the installation is subject to the terms and conditions of Pro Playgrounds "Standard Installation Agreement" a copy of which may be obtained from your Sales Representative.



Pro Playgrounds
8490 Cabin Hill Road
Tallahassee, FL 32311

Quote

Date	Estimate #
9/1/2023	21794

Project Name
Gadsden County SD - Chattahoo...



Customer / Bill To
Gadsden County School District Tammy McGriff 35 Martin Luther King Blvd Quincy, FL 32351

Ship To
Chattahoochee Elementary Johnny Riley 335 Maple Street Chattahoochee, FL 32324

WE WILL BEAT ANY PRICE BY 5%!

Item	Description	Qty	Cost	Total:
LBR	Labor for Demolition and Removal	1	11,126.25	11,126.25
LBR	Equipment Installation Per Contract	1	31,253.60	31,253.60
LBR	Surfacing Installation Per Contract	1	9,883.17	9,883.17
DSC	Discount - Per Contract Equipment	1	-8,929.60	-8,929.60
DSC	Discount - Per Contract Surfacing		-2,823.76	-2,823.76
DSC	Discount - Additional		-6,917.83	-6,917.83

AGREED AND ACCEPTED:
If the above total price, scope of work, specifications, terms and conditions are acceptable, sign below indicating your acceptance and authorization for Pro Playgrounds to proceed with the work and/or sales transaction described in this quotation. Upon signature and payment in accordance with this quote, Pro Playgrounds will proceed with the work and/or sales transaction.

Signature Name / Title Date

Subtotal:	\$179,999.00
Sales Tax: (7.5%)	\$0.00
Total:	<u>\$179,999.00</u>

Terms and Conditions - Price valid for 30 days and subject to change. 1. If installation is not included with your purchase, client will be responsible for coordinating, receiving and unloading of all goods, delivery drivers will not help unload goods. 2. Client will be responsible to inspect goods for defect, damage or missing parts, any deficiency or missing parts must be noted on delivery slip. 3. Client will be responsible for costs due to cancelled or missed delivery appointments. 4. Client has reviewed all items, colors and descriptions on this quote for accuracy and correctness. 5. If quote includes installation of goods, the installation is subject to the terms and conditions of Pro Playgrounds "Standard Installation Agreement" a copy of which may be obtained from your Sales Representative.

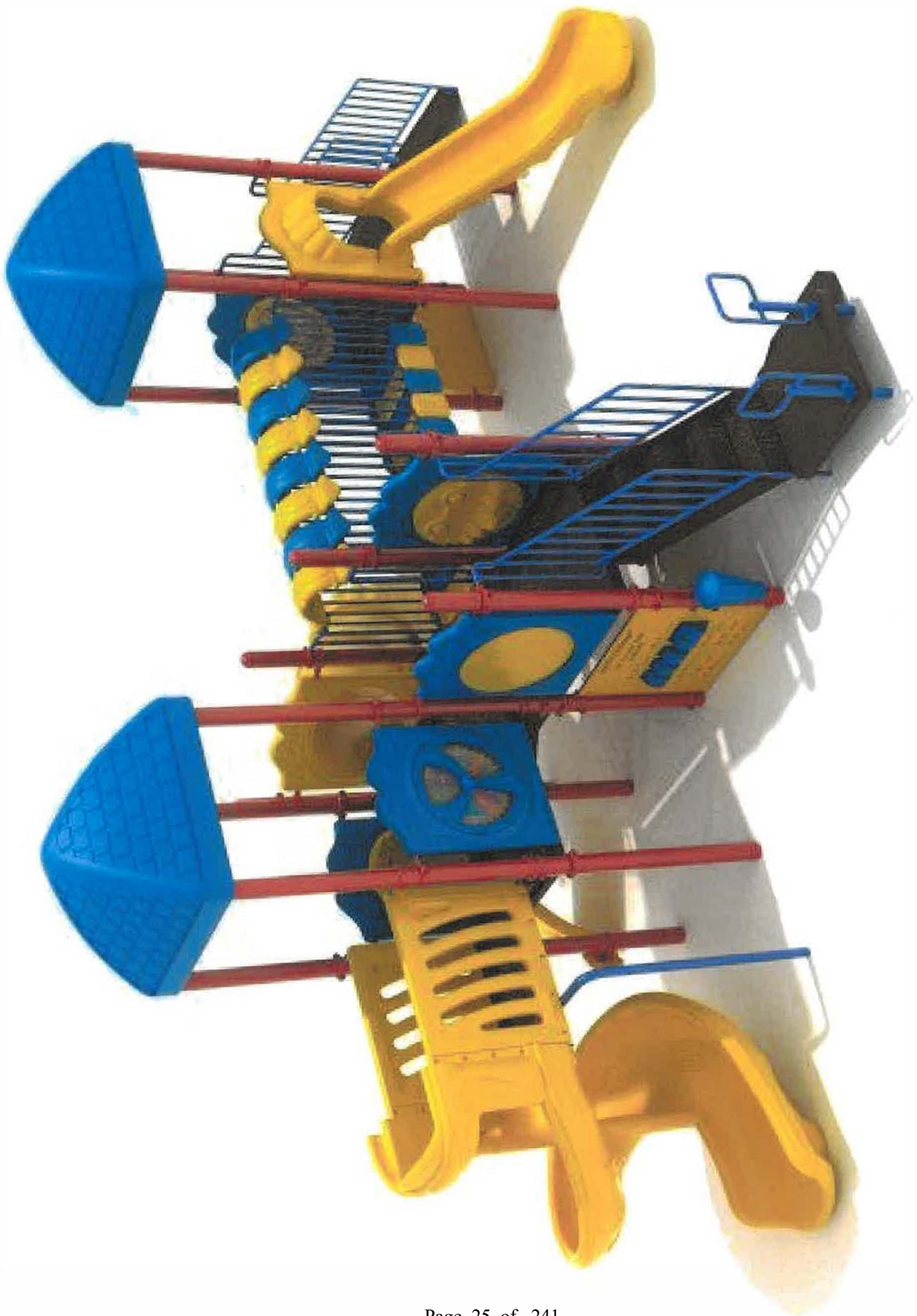

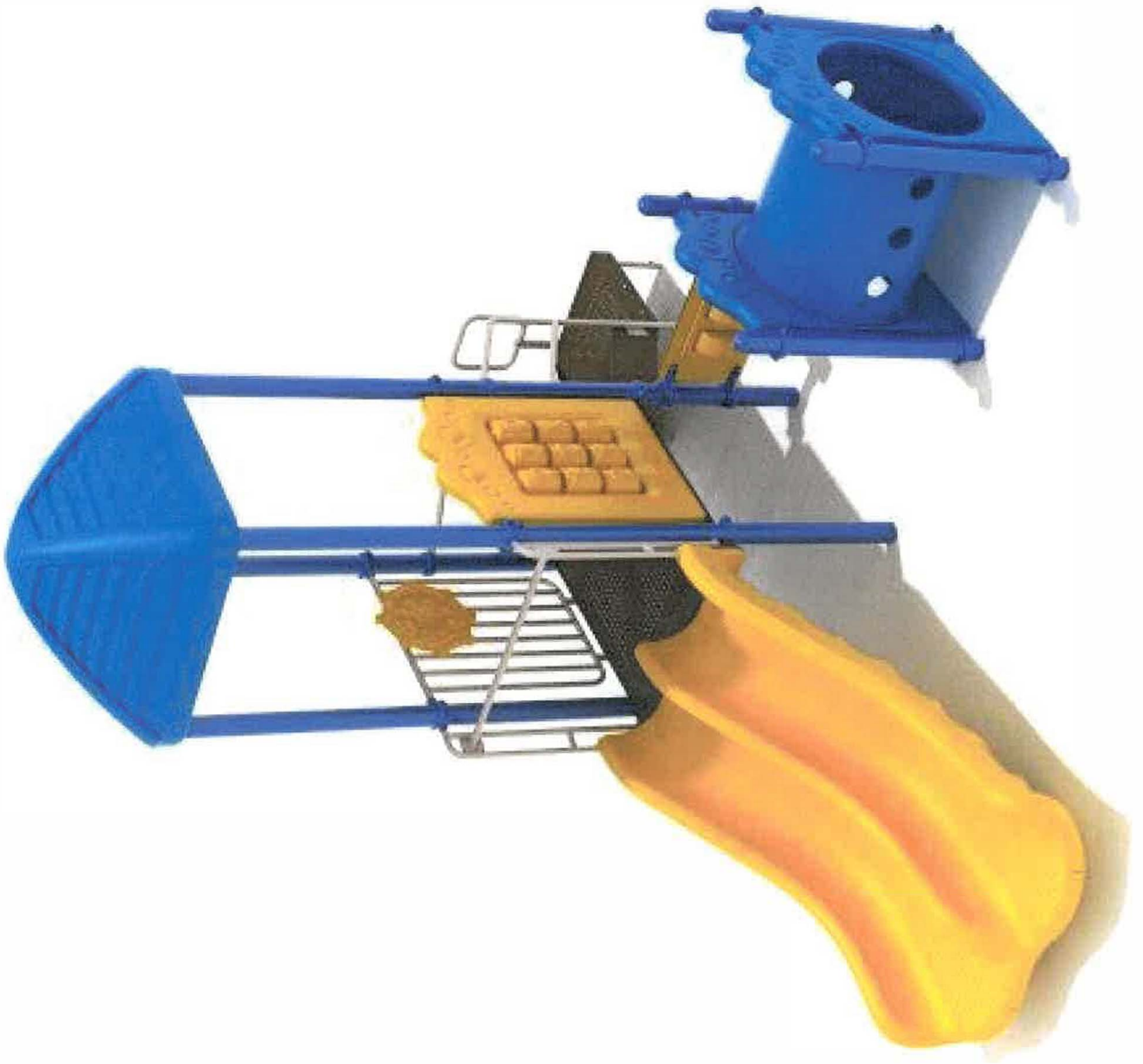

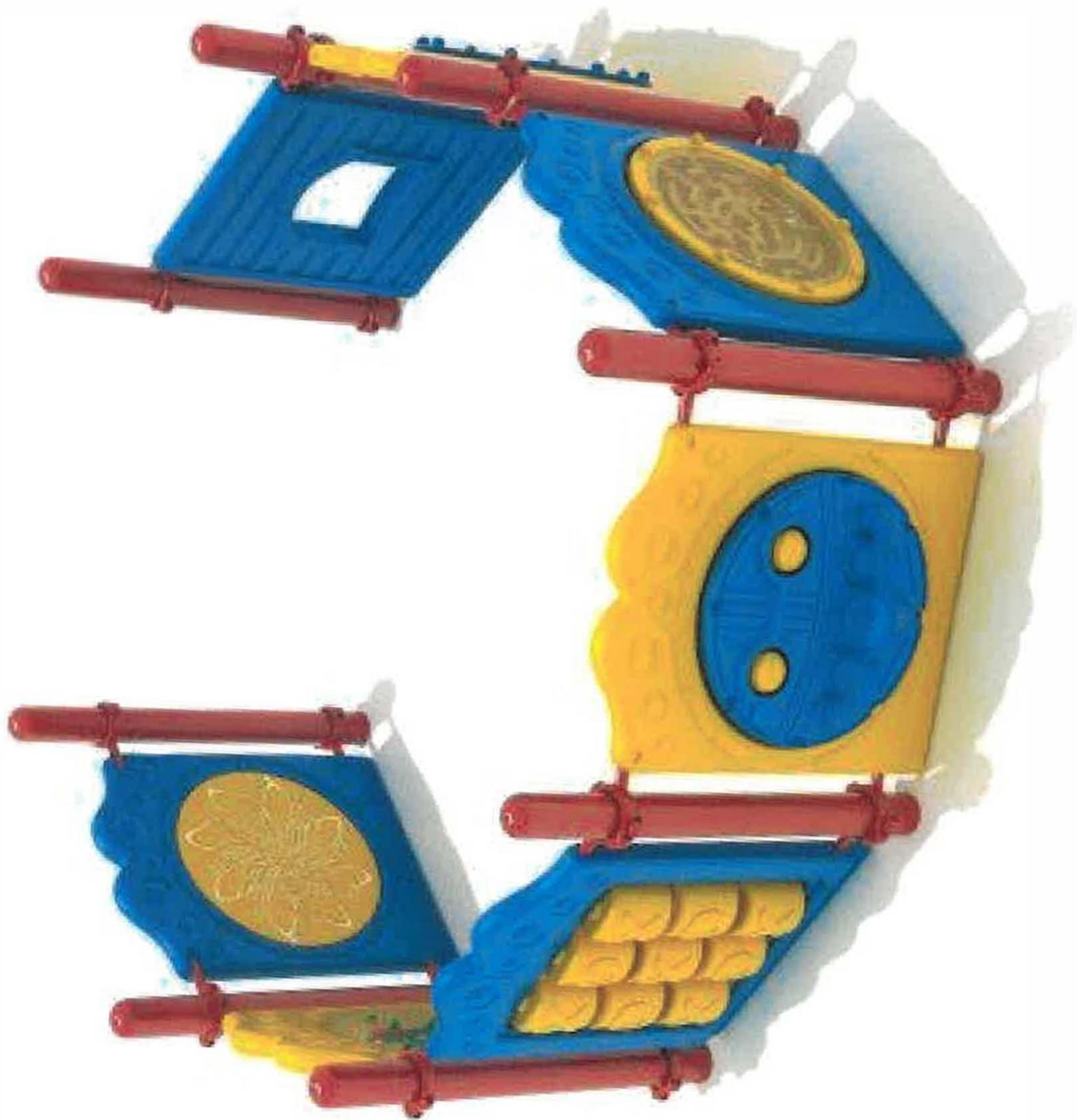



Hip Shade

Length	30'	Width	24'	Entry Height	10'
Peak Height	14.85'	Elbow	Glide	Column Mount	Embedded
Column Size	Ø5.5" Sch-40	Rafter Size	Ø3.5" 11-Ga	Ridge Size	Ø3.5" 11-Ga
Column Length	13'	Rafter Length	17.06'	Ridge Length	7.76'
Dome Qty.	1	Column Qty.	4		

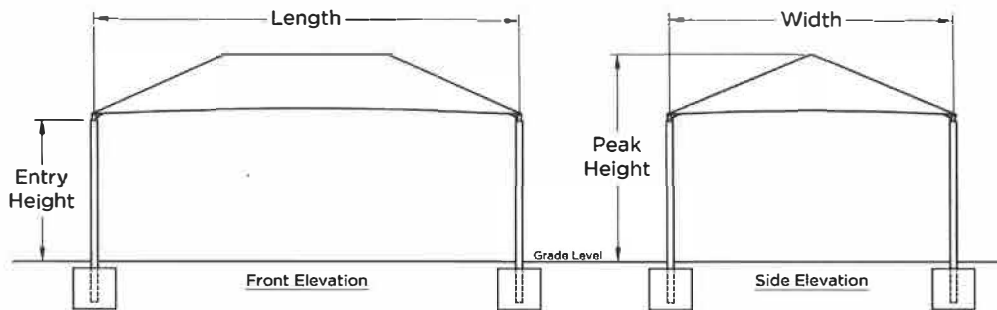
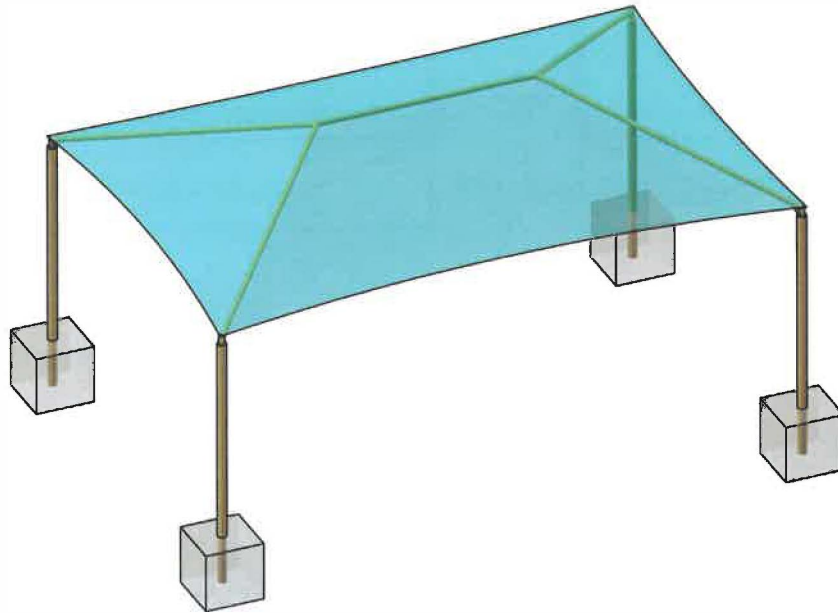

Square Footing		
Column	Length & Width	Depth
Single Cap	3.52	3
Double Cap	N/A	3

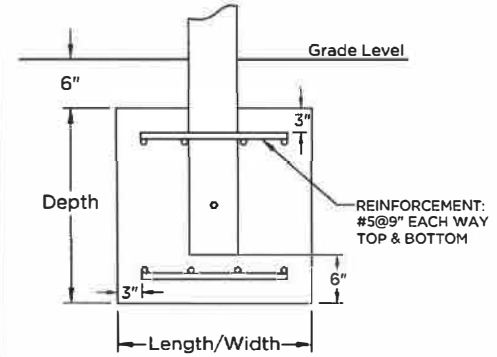

Auger Footing		
Diameter	Single Cap Depth	Double Cap Depth
1'-6"		
2'-0"	Out of range	N/A
2'-6"	Out of range	N/A
3'-0"	4.2	N/A

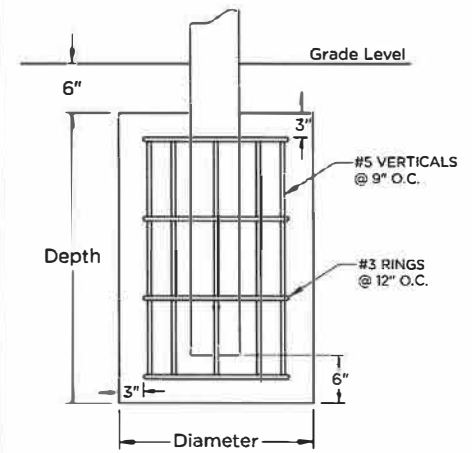

SuperiorShade

QUOTE

SHADE SIZE

30 X 24

SHADE STYLE

Hip Shade

These drawings are for reference only and should not be used as construction details. They show the general character and rough dimensions of the structural features. Exact spans, fasteners, materials, and foundations can be determined by a licensed professional engineer upon request. Estimated footing size above is based on 1,500 PSF soil bearing pressure.

Hip Shade

Length	45'	Width	28'	Entry Height	15'
Peak Height	20.65'	Elbow	Standard	Column Mount	Base Plate
Column Size	10"x10"x1/4"	Rafter Size	Ø5.0" 7-Ga	Ridge Size	Ø5.0" 7-Ga
Column Length	15.5'	Rafter Length	19.91'	Ridge Length	19.06'
Dome Qty.	1	Column Qty.	4		

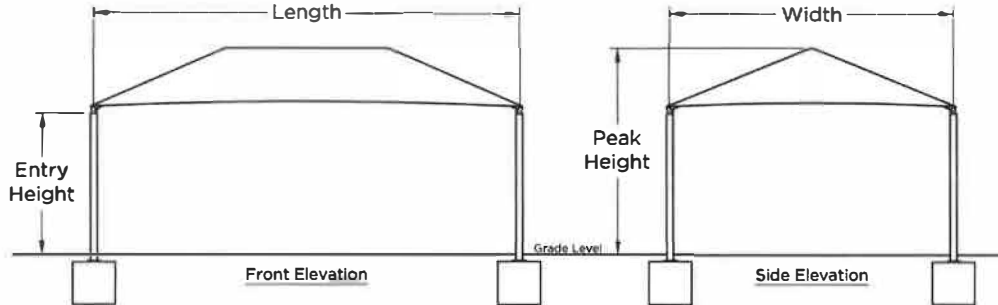
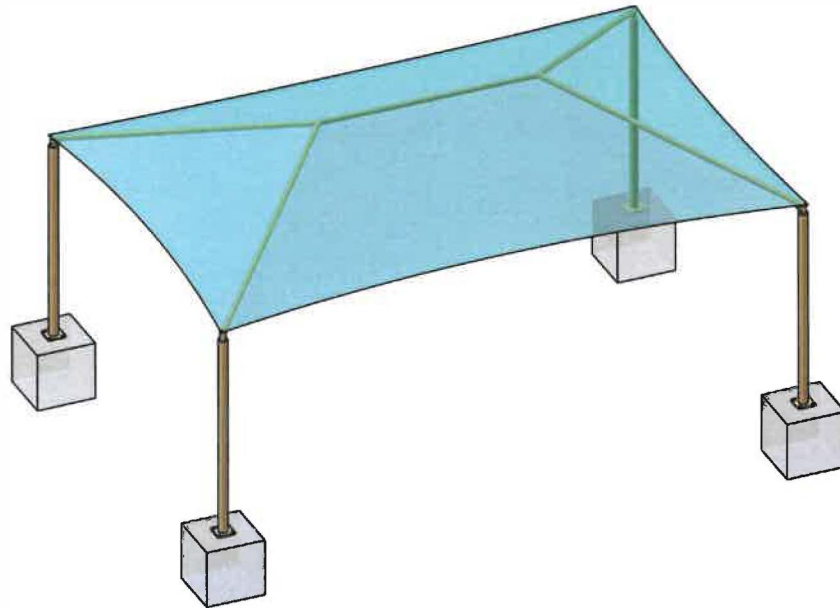

Square Footing		
Column	Length & Width	Depth
Single Cap	5.63	3
Double Cap	N/A	3

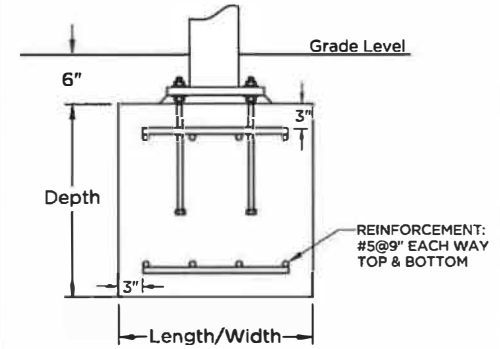

Auger Footing		
Diameter	Single Cap Depth	Double Cap Depth
1'-6"		
2'-0"	Out of range	N/A
2'-6"	Out of range	N/A
3'-0"	10.78	N/A

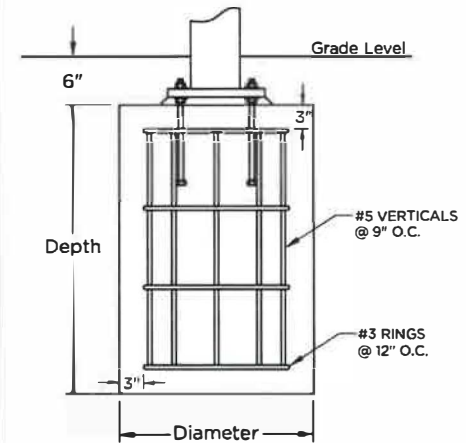

SuperiorShade

QUOTE

SHADE SIZE

45 X 28

SHADE STYLE

Hip Shade

These drawings are for reference only and should not be used as construction details. They show the general character and rough dimensions of the structural features. Exact spans, fasteners, materials, and foundations can be determined by a licensed professional engineer upon request. Estimated footing size above is based on 1,500 PSF soil bearing pressure.

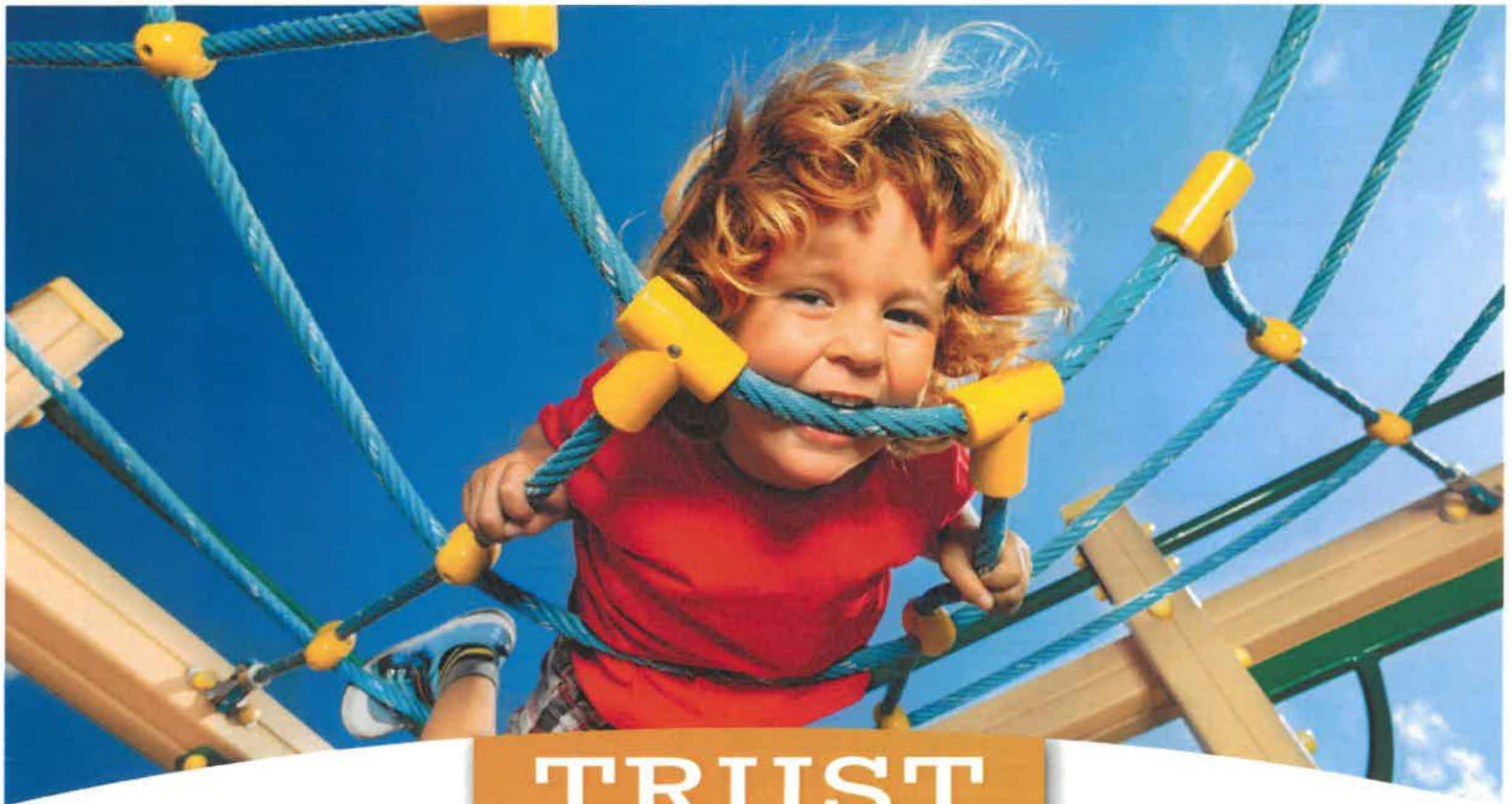

TRUST — the — EXPERTS

For over a decade, our customers have entrusted us to provide safe and affordable playground and recreational equipment. Our team of Certified General Contractors and Playground Safety Inspectors will insure that your project is completed to perfection, providing truly turnkey service, with every step of the process from planning and budgeting, through the installation being handled under one roof.



1-800-573-7529 | www.proplaygrounds.com



The Play & Recreation Experts

Pro Playgrounds
8490 Cabin Hill Road
Tallahassee, FL 32311

Quote

Table with 2 columns: Date, Estimate #. Values: 9/15/2023, 22059

Project Name: Gadsden County SD - Magnet El...



Customer / Bill To: Gadsden County School District, Tammy McGriff, 35 Martin Luther King Blvd, Quincy, FL 32351

Ship To: Gadsden Elementary Magnet, Johnny Riley, 200 Providence Rd., Quincy, FL 32351

WE WILL BEAT ANY PRICE BY 5%!

Main table with 5 columns: Item, Description, Qty, Cost, Total. Description includes labor and materials, general scope of work (remove sod, assemble benches/tables), notes (total square footage), and elementary playground area scope of work (install play system, swing set, panels, aggregate rock, rubber surfacing).

AGREED AND ACCEPTED: If the above total price, scope of work, specifications, terms and conditions are acceptable, sign below indicating your acceptance and authorization for Pro Playgrounds to proceed with the work and/or sales transaction described in this quotation. Includes signature, name/title, and date lines.

Summary table with Subtotal, Sales Tax: (7.5%), and Total rows.

Terms and Conditions - Price valid for 30 days and subject to change. 1. If installation is not included with your purchase, client will be responsible for coordinating, receiving and unloading of all goods, delivery drivers will not help unload goods. 2. Client will be responsible to inspect goods for defect, damage or missing parts, any deficiency or missing parts must be noted on delivery slip. 3. Client will be responsible for costs due to cancelled or missed delivery appointments. 4. Client has reviewed all items, colors and descriptions on this quote for accuracy and correctness. 5. If quote includes installation of goods, the installation is subject to the terms and conditions of Pro Playgrounds "Standard Installation Agreement" a copy of which may be obtained from your Sales Representative.



Pro Playgrounds
 8490 Cabin Hill Road
 Tallahassee, FL 32311

Quote

Date	Estimate #
9/15/2023	22059

Project Name
Gadsden County SD - Magnet El...



Customer / Bill To
Gadsden County School District Tammy McGriff 35 Martin Luther King Blvd Quincy, FL 32351

Ship To
Gadsden Elementary Magnet Johnny Riley 200 Providence Rd. Quincy, FL 32351

WE WILL BEAT ANY PRICE BY 5%!

Item	Description	Qty	Cost	Total:
	<p>black tpv .5" granule mix (3.5" total rubber thickness) over an aggregate rock subbase. 7.) Install 1x 45'x28'x15' Standard Hip Shade (on base plates)</p> <p>**NOTES** -Surfacing Area is 43'x23' - Playground -Surfacing Area is 32'x32' - Swing set -Total square footage is 2,013</p> <p>**PRE-K/KINDERGARTEN PLAYGROUND SCOPE OF WORK** 1.) Install 1x Ketchum Playground System 2.) Install 10 tons of aggregate rock subbase. 3.) Install 572 square feet of poured in place rubber surfacing with a 1.5" SBR thickness (4' fall height compliance) with a 50% color tpv and 50% black tpv .5" granule mix (2" total rubber thickness) over an aggregate rock subbase. 4.) Install 1x 30'x24'x10' Hip Shade with Glide (inground mount)</p> <p>**NOTES** -Surfacing area is 26'x22' -Total Square footage is 572</p>			

AGREED AND ACCEPTED:
 If the above total price, scope of work, specifications, terms and conditions are acceptable, sign below indicating your acceptance and authorization for Pro Playgrounds to proceed with the work and/or sales transaction described in this quotation. Upon signature and payment in accordance with this quote, Pro Playgrounds will proceed with the work and/or sales transaction.

Signature _____ Name / Title _____ Date _____

Subtotal:
Sales Tax: (7.5%)
Total:

Terms and Conditions - Price valid for 30 days and subject to change. 1. If installation is not included with your purchase, client will be responsible for coordinating, receiving and unloading of all goods, delivery drivers will not help unload goods. 2. Client will be responsible to inspect goods for defect, damage or missing parts, any deficiency or missing parts must be noted on delivery slip. 3. Client will be responsible for costs due to cancelled or missed delivery appointments. 4. Client has reviewed all items, colors and descriptions on this quote for accuracy and correctness. 5. If quote includes installation of goods, the installation is subject to the terms and conditions of Pro Playgrounds "Standard Installation Agreement" a copy of which may be obtained from your Sales Representative.



Pro Playgrounds
8490 Cabin Hill Road
Tallahassee, FL 32311

Quote

Date	Estimate #
9/15/2023	22059

Project Name
Gadsden County SD - Magnet El...



Customer / Bill To
Gadsden County School District Tammy McGriff 35 Martin Luther King Blvd Quincy, FL 32351

Ship To
Gadsden Elementary Magnet Johnny Riley 200 Providence Rd. Quincy, FL 32351

WE WILL BEAT ANY PRICE BY 5%!

Item	Description	Qty	Cost	Total:
	PLAY EQUIPMENT			
QS-23-PSW120...	1 Bay 2 Cantilevers - Frame w/ Hangers, 1 Bay Belt Seat Package, 1 Bay Bucket Package	1	1,699.00	1,699.00
23-PMF035	Barrington Ridge	1	36,839.00	36,839.00
QS-23-PPK025P	Camp Walden - Primary	1	5,913.00	5,913.00
	KINDERGARTEN/PRE-K PLAYGROUND			
Shipping	Combined Shipping and Freight Charges	1	3,600.00	3,600.00
23-PPK260	Ketchum	1	9,153.00	9,153.00
	SHADE/SHELTER			
22-RD243010IG	30'x24'x10' Height -INGROUND - WITH GLIDE - RECTANGLE	1	9,799.00	9,799.00
Shipping	Combined Shipping and Freight Charges	1	1,188.55	1,188.55
CSSD	Custom Shade Design - 45'x28'x15' Standard Hip Shade (on base plates)	1	21,199.00	21,199.00
	SITE AMMENITIES			
22-T6ULHDCP	6' UltraLeisureAccessible Rectangular Portable Table*	1	1,199.00	1,199.00
22-T6UL	6' UltraLeisureRectangular Portable Table	1	1,099.00	1,099.00
22-B6WBULP	6' UltraLeisureStandard Bench with Back, Portable	4	599.00	2,396.00
Shipping	Combined Shipping and Freight Charges	1	1,366.60	1,366.60

AGREED AND ACCEPTED:
If the above total price, scope of work, specifications, terms and conditions are acceptable, sign below indicating your acceptance and authorization for Pro Playgrounds to proceed with the work and/or sales transaction described in this quotation. Upon signature and payment in accordance with this quote, Pro Playgrounds will proceed with the work and/or sales transaction.

_____/_____/_____
Signature Name / Title Date

Subtotal:
Sales Tax: (7.5%)
Total:

Terms and Conditions - Price valid for 30 days and subject to change. 1. If installation is not included with your purchase, client will be responsible for coordinating, receiving and unloading of all goods, delivery drivers will not help unload goods. 2. Client will be responsible to inspect goods for defect, damage or missing parts, any deficiency or missing parts must be noted on delivery slip. 3. Client will be responsible for costs due to cancelled or missed delivery appointments. 4. Client has reviewed all items, colors and descriptions on this quote for accuracy and correctness. 5. If quote includes installation of goods, the installation is subject to the terms and conditions of Pro Playgrounds "Standard Installation Agreement" a copy of which may be obtained from your Sales Representative.



Pro Playgrounds
8490 Cabin Hill Road
Tallahassee, FL 32311

Quote

Date	Estimate #
9/15/2023	22059

Project Name
Gadsden County SD - Magnet El...



WE WILL BEAT ANY PRICE BY 5%!

Customer / Bill To	Ship To
Gadsden County School District Tammy McGriff 35 Martin Luther King Blvd Quincy, FL 32351	Gadsden Elementary Magnet Johnny Riley 200 Providence Rd. Quincy, FL 32351

Item	Description	Qty	Cost	Total:
SURFACING MATERIALS				
TPV-CT	Color TPV Granules T	55	106.11455	5,836.30
Shipping	Combined Shipping and Freight Charges	1	2,520.00	2,520.00
AROFT	PremArc Aromatic Binder-T Pail	8	188.50	1,508.00
ARODT	PremArc Aromatic T Binder Drum	6	1,741.57167	10,449.43
TPV-BT	Premium 1350 Black Granules T	55	37.88091	2,083.45
SBRT	SBR Buffings T	268	30.95239	8,295.24
RAW MATERIALS				
CC80	Concrete for Anchoring - Delivered Cost	104	8.40	873.60
FBLOCK	Footer Blocks	80	3.75	300.00
AGG	Locally sourced crushed aggregate base materials (ABC Crush and Run Typical)	7	45.00	315.00
RBAR5	No. 5 Rebar	950	1.25	1,187.50
RMC	Ready Mix Concrete 2500 PSI MIN	21	200.00	4,200.00
RENTALS, LABOR, AND INSTALLATION				
22-Rentals	Rentals Necessary for Installation	1	8,805.92	8,805.92
LBR	Labor and Installation - Demolition or Removal	1	5,250.00	5,250.00
LBR	Equipment Installation Per Contract	1	31,953.60	31,953.60
LBR	Surfacing Installation Per Contract	1	9,860.35	9,860.35
DSC	Discount - Per Contract Equipment		-9,129.60	-9,129.60
DSC	Discount - Per Contract Surfacing		-2,817.24	-2,817.24
DSC	Discount - Additional		-6,943.70	-6,943.70

AGREED AND ACCEPTED:
If the above total price, scope of work, specifications, terms and conditions are acceptable, sign below indicating your acceptance and authorization for Pro Playgrounds to proceed with the work and/or sales transaction described in this quotation. Upon signature and payment in accordance with this quote, Pro Playgrounds will proceed with the work and/or sales transaction.

Signature _____ Name / Title _____ Date _____

Subtotal:	\$169,999.00
Sales Tax: (7.5%)	\$0.00
Total:	\$169,999.00

Terms and Conditions - Price valid for 30 days and subject to change. 1. If installation is not included with your purchase, client will be responsible for coordinating, receiving and unloading of all goods, delivery drivers will not help unload goods. 2. Client will be responsible to inspect goods for defect, damage or missing parts, any deficiency or missing parts must be noted on delivery slip. 3. Client will be responsible for costs due to cancelled or missed delivery appointments. 4. Client has reviewed all items, colors and descriptions on this quote for accuracy and correctness. 5. If quote includes installation of goods, the installation is subject to the terms and conditions of Pro Playgrounds "Standard Installation Agreement" a copy of which may be obtained from your Sales Representative.





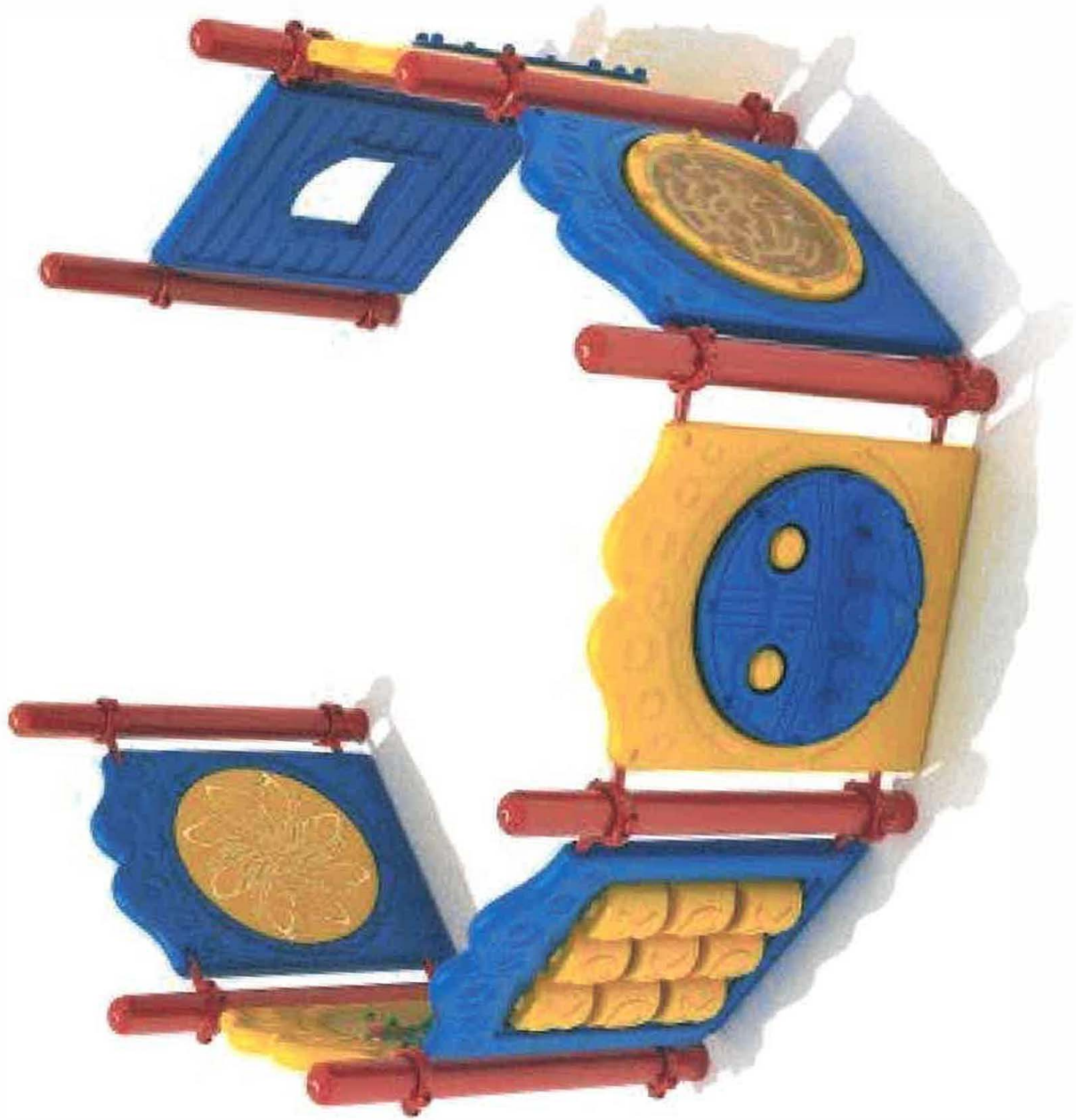







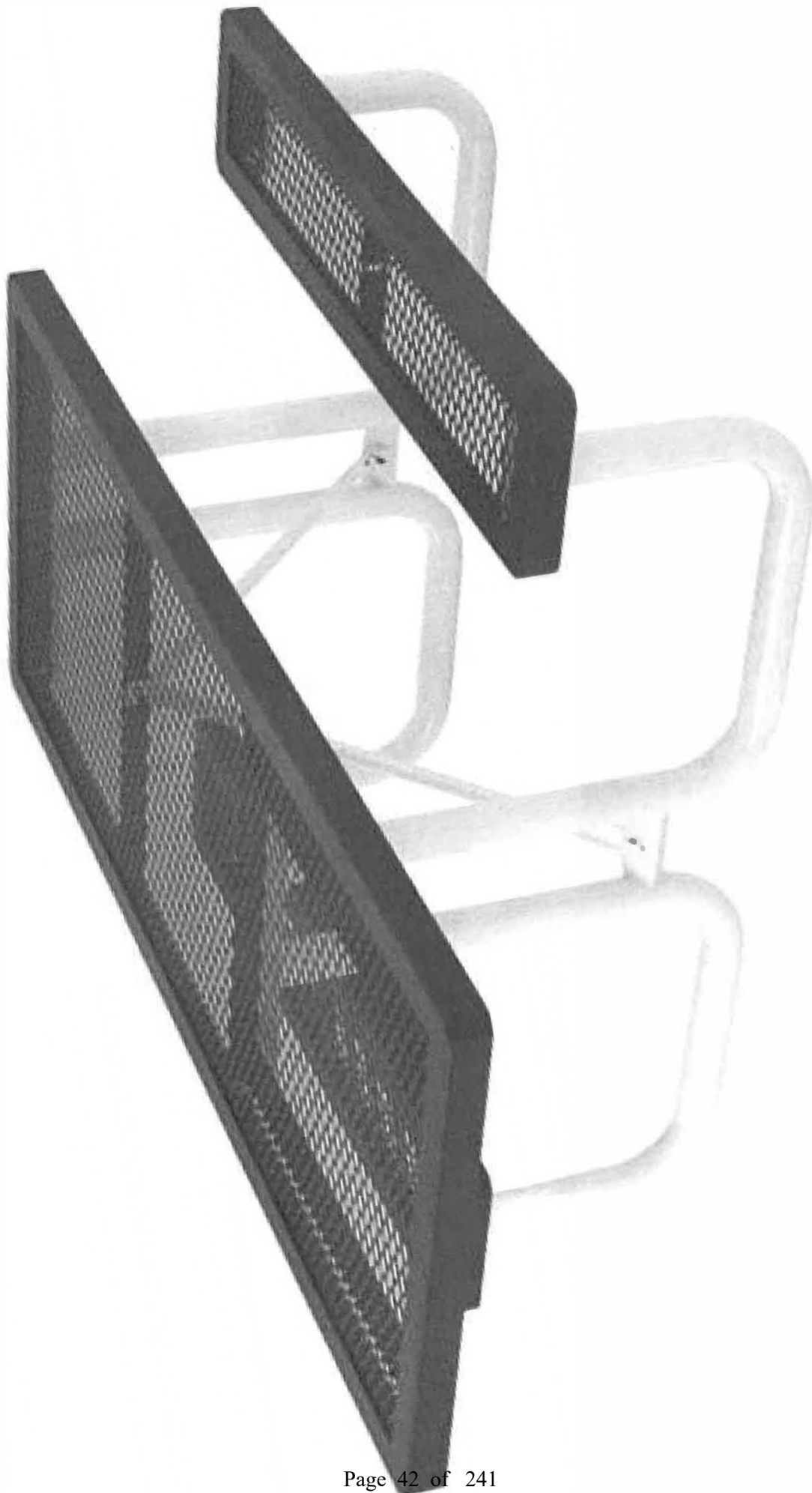

Hip Shade

Length	30'	Width	24'	Entry Height	10'
Peak Height	14.85'	Elbow	Glide	Column Mount	Embedded
Column Size	Ø5.5" Sch-40	Rafter Size	Ø3.5" 11-Ga	Ridge Size	Ø3.5" 11-Ga
Column Length	13'	Rafter Length	17.06'	Ridge Length	7.76'
Dome Qty.	1	Column Qty.	4		

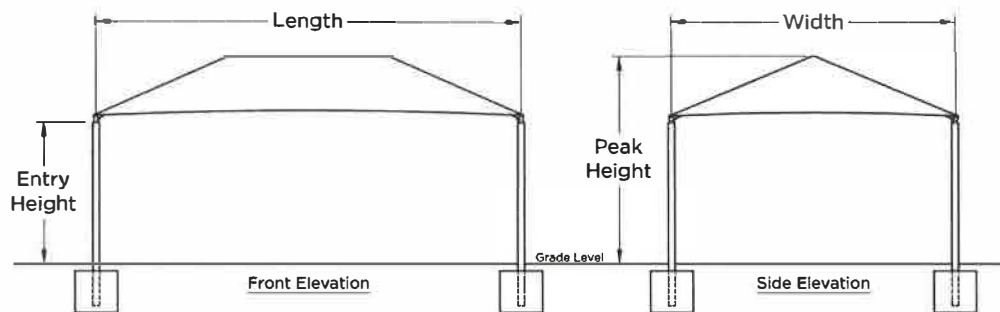
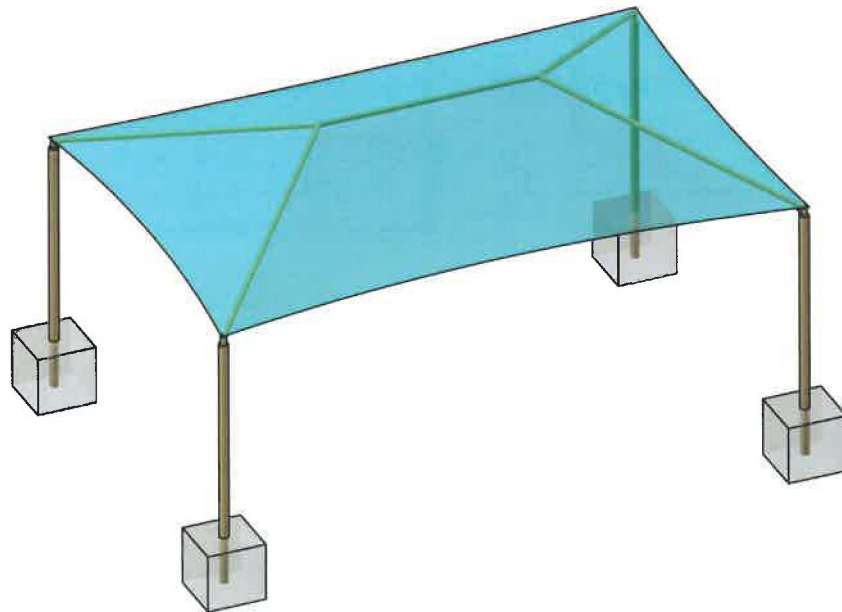

Square Footing		
Column	Length & Width	Depth
Single Cap	3.52	3
Double Cap	N/A	3

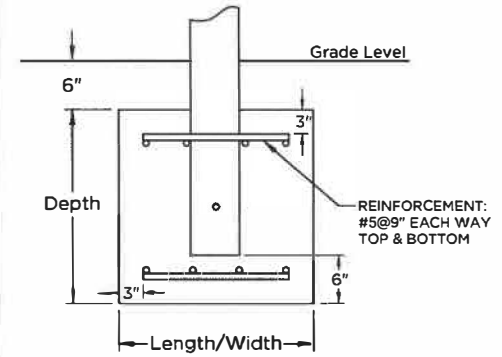

Auger Footing		
Diameter	Single Cap Depth	Double Cap Depth
1'-6"		
2'-0"	Out of range	N/A
2'-6"	Out of range	N/A
3'-0"	4.2	N/A

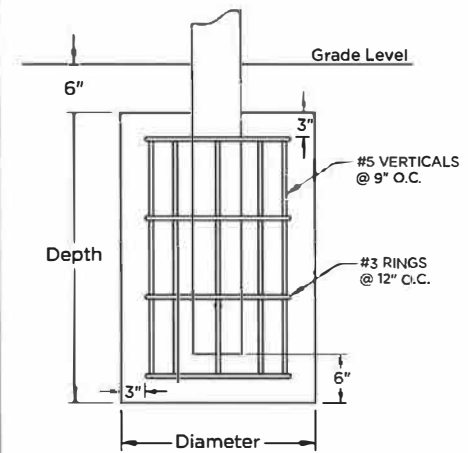

SuperiorShade

QUOTE

SHADE SIZE

30 X 24

SHADE STYLE

Hip Shade

These drawings are for reference only and should not be used as construction details. They show the general character and rough dimensions of the structural features. Exact spans, fasteners, materials, and foundations can be determined by a licensed professional engineer upon request. Estimated footing size above is based on 1,500 PSF soil bearing pressure.

Hip Shade

Length	45'	Width	28'	Entry Height	15'
Peak Height	20.65'	Elbow	Standard	Column Mount	Base Plate
Column Size	10"x10"x1/4"	Rafter Size	Ø5.0" 7-Ga	Ridge Size	Ø5.0" 7-Ga
Column Length	15.5'	Rafter Length	19.91'	Ridge Length	19.06'
Dome Qty.	1	Column Qty.	4		

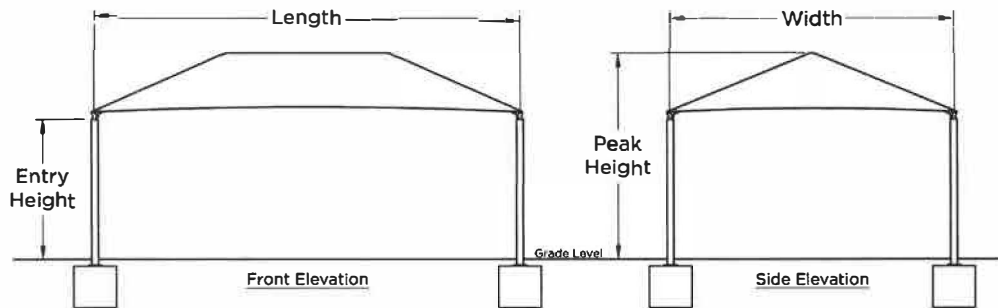
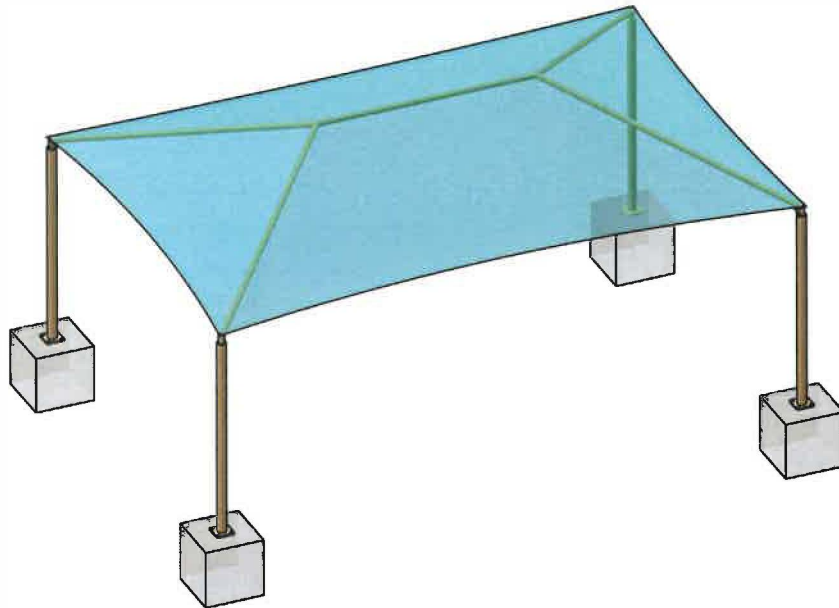

Column	Length & Width	Depth
Single Cap	5.63	3
Double Cap	N/A	3

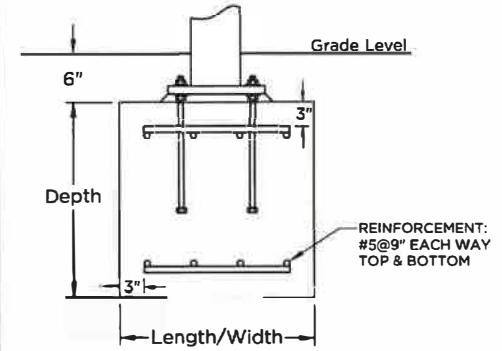

Diameter	Single Cap Depth	Double Cap Depth
1'-6"		
2'-0"	Out of range	N/A
2'-6"	Out of range	N/A
3'-0"	10.78	N/A

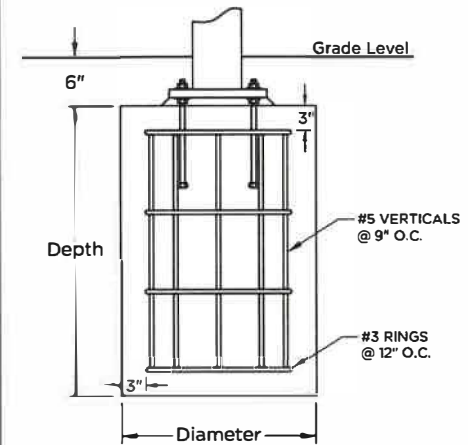

SuperiorShade

QUOTE

SHADE SIZE
45 X 28

SHADE STYLE
Hip Shade

These drawings are for reference only and should not be used as construction details. They show the general character and rough dimensions of the structural features. Exact spans, fasteners, materials, and foundations can be determined by a licensed professional engineer upon request. Estimated footing size above is based on 1,500 PSF soil bearing pressure.

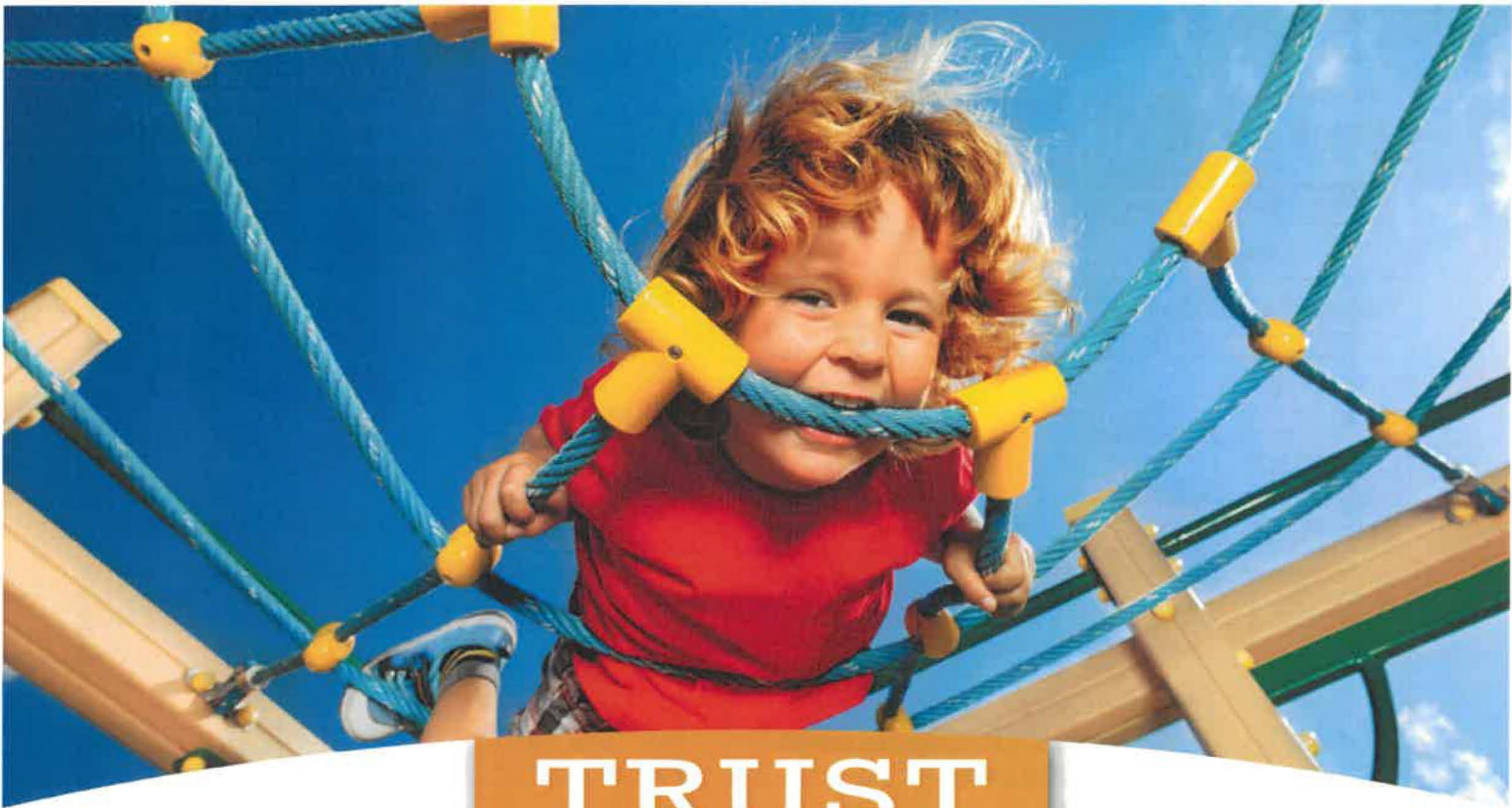

TRUST
— *the* —
EXPERTS

For over a decade, our customers have entrusted us to provide safe and affordable playground and recreational equipment. Our team of Certified General Contractors and Playground Safety Inspectors will insure that your project is completed to perfection, providing truly turnkey service, with every step of the process from planning and budgeting, through the installation being handled under one roof.



1-800-573-7529 | www.proplaygrounds.com



Pro Playgrounds
 8490 Cabin Hill Road
 Tallahassee, FL 32311

Quote

Date	Estimate #
9/14/2023	22037

Project Name
 Gadsden County SD - George M...



Customer / Bill To
 Gadsden County School District
 Tammy McGriff
 35 Martin Luther King Blvd
 Quincy, FL 32351

Ship To
 George Munroe Elementary
 Johnnie Riley
 1830 West King Street
 Quincy, FL 32351

WE WILL BEAT ANY PRICE BY 5%!

Item	Description	Qty	Cost	Total:
	Furnish labor and materials to: **GENERAL SCOPE OF WORK** 1.) Remove existing playground equipment a.) 1x 2 deck play system b.) 1x climber c.) 1x 4 bay swing set d.) 1x double slide 2.) Remove existing borders and 5,800 square feet of existing wood mulch surfacing 3.) Assemble 4x Portable Metal Outdoor Benches 4.) Assemble 1x Portable Picnic Table 5.) Assemble 1x Portable ADA Picnic Table **NOTES** -Total square footage is 2,585 **ELEMENTARY PLAYGROUND AREA SCOPE OF WORK** 1.) Install 1x Barrington Ridge Play System 2.) Install 1x 1 Bay 2 Cantilever Swing Set 3.) Install 1x Camp Walden Interactive Panels 4.) Install 37 tons of aggregate rock subbase 5.) Install 989 square feet of poured in place rubber surfacing with a 2" SBR thickness (6' fall height)			

AGREED AND ACCEPTED:
 If the above total price, scope of work, specifications, terms and conditions are acceptable, sign below indicating your acceptance and authorization for Pro Playgrounds to proceed with the work and/or sales transaction described in this quotation. Upon signature and payment in accordance with this quote, Pro Playgrounds will proceed with the work and/or sales transaction.

 Signature Name / Title Date

Subtotal:
Sales Tax: (7.5%)
Total:

Terms and Conditions - Price valid for 30 days and subject to change. 1. If installation is not included with your purchase, client will be responsible for coordinating, receiving and unloading of all goods, delivery drivers will not help unload goods. 2. Client will be responsible to inspect goods for defect, damage or missing parts, any deficiency or missing parts must be noted on delivery slip. 3. Client will be responsible for costs due to cancelled or missed delivery appointments. 4. Client has reviewed all items, colors and descriptions on this quote for accuracy and correctness. 5. If quote includes installation of goods, the installation is subject to the terms and conditions of Pro Playgrounds "Standard Installation Agreement" a copy of which may be obtained from your Sales Representative.



Pro Playgrounds
8490 Cabin Hill Road
Tallahassee, FL 32311

Quote

Date	Estimate #
9/14/2023	22037

Project Name
Gadsden County SD - George M...



Customer / Bill To
Gadsden County School District Tammy McGriff 35 Martin Luther King Blvd Quincy, FL 32351

Ship To
George Munroe Elementary Johnnie Riley 1830 West King Street Quincy, FL 32351



WE WILL BEAT ANY PRICE BY 5%!

Item	Description	Qty	Cost	Total:
	<p>compliance) with a 50% color tpv and 50% black tpv .5" granule mix (2.5" total rubber thickness) over an aggregate rock subbase.</p> <p>6.) Install 1,024 square feet of poured in place rubber surfacing with 3" SBR thickness (8' fall height compliance) with a 50% color tpv and 50% black tpv .5" granule mix (3.5" total rubber thickness) over an aggregate rock subbase.</p> <p>7.) Install 1x 45'x28'x15' Standard Hip Shade (on base plates)</p> <p>**NOTES** -Surfacing Area is 43'x23' - Playground -Surfacing Area is 32'x32' - Swing set -Total square footage is 2,013</p> <p>**PRE-K/KINDERGARTEN PLAYGROUND SCOPE OF WORK** 1.) Install 1x Ketchum Playground System 2.) Install 10 tons of aggregate rock subbase. 3.) Install 572 square feet of poured in place rubber surfacing with a 1.5" SBR thickness (4' fall height compliance) with a 50% color tpv and 50% black tpv .5" granule mix (2" total rubber thickness) over an aggregate rock subbase.</p>			

AGREED AND ACCEPTED:

If the above total price, scope of work, specifications, terms and conditions are acceptable, sign below indicating your acceptance and authorization for Pro Playgrounds to proceed with the work and/or sales transaction described in this quotation. Upon signature and payment in accordance with this quote, Pro Playgrounds will proceed with the work and/or sales transaction.

Signature _____ Name / Title _____ Date _____

Subtotal:

Sales Tax: (7.5%)

Total:

Terms and Conditions - Price valid for 30 days and subject to change. 1. If installation is not included with your purchase, client will be responsible for coordinating, receiving and unloading of all goods, delivery drivers will not help unload goods. 2. Client will be responsible to inspect goods for defect, damage or missing parts, any deficiency or missing parts must be noted on delivery slip. 3. Client will be responsible for costs due to cancelled or missed delivery appointments. 4. Client has reviewed all items, colors and descriptions on this quote for accuracy and correctness. 5. If quote includes installation of goods, the installation is subject to the terms and conditions of Pro Playgrounds "Standard Installation Agreement" a copy of which may be obtained from your Sales Representative.



Pro Playgrounds
8490 Cabin Hill Road
Tallahassee, FL 32311

Quote

Date	Estimate #
9/14/2023	22037

Project Name
Gadsden County SD - George M...



Customer / Bill To
Gadsden County School District Tammy McGriff 35 Martin Luther King Blvd Quincy, FL 32351

Ship To
George Munroe Elementary Johnnie Riley 1830 West King Street Quincy, FL 32351

WE WILL BEAT ANY PRICE BY 5%!

Item	Description	Qty	Cost	Total:
	4.) Install 1x 30'x24'x10' Hip Shade with Glide (inground mount)			
	NOTES -Surfacing area is 26'x22' -Total Square footage is 572			
	PLAY EQUIPMENT			
23-PMF035	Barrington Ridge	1	36,839.00	36,839.00
QS-23-PKP025P	Camp Walden - Primary	1	5,913.00	5,913.00
QS-23-PSW120...	1 Bay 2 Cantilevers - Frame w/ Hangers, 1 Bay Belt Seat Package, 1 Bay Bucket Package	1	1,699.00	1,699.00
	KINDERGARTEN/PRE-K PLAYGROUND			
23-PKP260	Ketchum	1	9,153.00	9,153.00
Shipping	Combined Shipping and Freight Charges	1	3,600.00	3,600.00
	SHADE/SHELTER			
CSSD	Custom Shade Design - 45'x28'x15' Standard Hip Shade (on base plates)	1	21,199.00	21,199.00
22-RD243010IG	30'x24'x10' Height -INGROUND - WITH GLIDE - RECTANGLE	1	9,799.00	9,799.00
Shipping	Combined Shipping and Freight Charges	1	1,188.55	1,188.55
	SITE AMMENITIES			

AGREED AND ACCEPTED:
If the above total price, scope of work, specifications, terms and conditions are acceptable, sign below indicating your acceptance and authorization for Pro Playgrounds to proceed with the work and/or sales transaction described in this quotation. Upon signature and payment in accordance with this quote, Pro Playgrounds will proceed with the work and/or sales transaction.

_____/_____/_____
Signature Name / Title Date

Subtotal:
Sales Tax: (7.5%)
Total:

Terms and Conditions - Price valid for 30 days and subject to change. 1. If installation is not included with your purchase, client will be responsible for coordinating, receiving and unloading of all goods, delivery drivers will not help unload goods. 2. Client will be responsible to inspect goods for defect, damage or missing parts, any deficiency or missing parts must be noted on delivery slip. 3. Client will be responsible for costs due to cancelled or missed delivery appointments. 4. Client has reviewed all items, colors and descriptions on this quote for accuracy and correctness. 5. If quote includes installation of goods, the installation is subject to the terms and conditions of Pro Playgrounds "Standard Installation Agreement" a copy of which may be obtained from your Sales Representative.



Pro Playgrounds
 8490 Cabin Hill Road
 Tallahassee, FL 32311

Quote

Project Name
 Gadsden County SD - George M...



Date	Estimate #
9/14/2023	22037



Customer / Bill To
 Gadsden County School District
 Tammy McGriff
 35 Martin Luther King Blvd
 Quincy, FL 32351

Ship To
 George Munroe Elementary
 Johnnie Riley
 1830 West King Street
 Quincy, FL 32351

WE WILL BEAT ANY PRICE BY 5%!

Item	Description	Qty	Cost	Total:
22-B6WBULP	6' UltraLeisureStandard Bench with Back, Portable	4	599.00	2,396.00
22-T6UL	6' UltraLeisureRectangular Portable Table	1	1,099.00	1,099.00
22-T6ULHDCP	6' UltraLeisureAccessible Rectangular Portable Table*	1	1,199.00	1,199.00
Shipping	Combined Shipping and Freight Charges	1	1,366.60	1,366.60
SURFACING MATERIALS				
TPV-BT	Premium 1350 Black Granules T	55	37.88091	2,083.45
TPV-CT	Color TPV Granules T	55	106.11455	5,836.30
SBRT	SBR Buffings T	268	30.95239	8,295.24
ARODT	PremArc Aromatic T Binder Drum	6	1,741.57167	10,449.43
AROFT	PremArc Aromatic Binder-T Pail	8	188.50	1,508.00
Shipping	Combined Shipping and Freight Charges	1	2,520.00	2,520.00
RAW MATERIALS				
AGG	Locally sourced crushed aggregate base materials (ABC Crush and Run Typical)	7	45.00	315.00
FBLOCK	Footer Blocks	80	3.75	300.00
CC80	Concrete for Anchoring - Delivered Cost	104	8.40	873.60
RBAR5	No. 5 Rebar	950	1.25	1,187.50
RMC	Ready Mix Concrete 2500 PSI MIN	21	200.00	4,200.00
RENTALS, LABOR, AND INSTALLATION				
22-Rentals	Rentals Necessary for Installation	1	16,766.18	16,766.18
LBR	Demolition and Removal	1	22,252.50	22,252.50

AGREED AND ACCEPTED:
 If the above total price, scope of work, specifications, terms and conditions are acceptable, sign below indicating your acceptance and authorization for Pro Playgrounds to proceed with the work and/or sales transaction described in this quotation. Upon signature and payment in accordance with this quote, Pro Playgrounds will proceed with the work and/or sales transaction.

_____/_____/_____
 Signature Name / Title Date

Subtotal:
Sales Tax: (7.5%)
Total:

Terms and Conditions - Price valid for 30 days and subject to change. 1. If installation is not included with your purchase, client will be responsible for coordinating, receiving and unloading of all goods, delivery drivers will not help unload goods. 2. Client will be responsible to inspect goods for defect, damage or missing parts, any deficiency or missing parts must be noted on delivery slip. 3. Client will be responsible for costs due to cancelled or missed delivery appointments. 4. Client has reviewed all items, colors and descriptions on this quote for accuracy and correctness. 5. If quote includes installation of goods, the installation is subject to the terms and conditions of Pro Playgrounds "Standard Installation Agreement" a copy of which may be obtained from your Sales Representative.



Pro Playgrounds
8490 Cabin Hill Road
Tallahassee, FL 32311

Quote

Date	Estimate #
9/14/2023	22037

Project Name
Gadsden County SD - George M...



Customer / Bill To
Gadsden County School District Tammy McGriff 35 Martin Luther King Blvd Quincy, FL 32351

Ship To
George Munroe Elementary Johnnie Riley 1830 West King Street Quincy, FL 32351

WE WILL BEAT ANY PRICE BY 5%!

Item	Description	Qty	Cost	Total:
LBR	Equipment Installation Per Contract	1	31,253.60	31,253.60
LBR	Surfacing Installation Per Contract	1	9,860.35	9,860.35
DSC	Discount - Per Contract Equipment		-8,929.60	-8,929.60
DSC	Discount - Per Contract Surfacing		-2,817.25	-2,817.25
DSC	Discount - Additional		-5,406.45	-5,406.45

AGREED AND ACCEPTED:
If the above total price, scope of work, specifications, terms and conditions are acceptable, sign below indicating your acceptance and authorization for Pro Playgrounds to proceed with the work and/or sales transaction described in this quotation. Upon signature and payment in accordance with this quote, Pro Playgrounds will proceed with the work and/or sales transaction.

Signature Name / Title Date

Subtotal:	\$195,999.00
Sales Tax: (7.5%)	\$0.00
Total:	\$195,999.00

Terms and Conditions - Price valid for 30 days and subject to change. 1. If installation is not included with your purchase, client will be responsible for coordinating, receiving and unloading of all goods, delivery drivers will not help unload goods. 2. Client will be responsible to inspect goods for defect, damage or missing parts, any deficiency or missing parts must be noted on delivery slip. 3. Client will be responsible for costs due to cancelled or missed delivery appointments. 4. Client has reviewed all items, colors and descriptions on this quote for accuracy and correctness. 5. If quote includes installation of goods, the installation is subject to the terms and conditions of Pro Playgrounds "Standard Installation Agreement" a copy of which may be obtained from your Sales Representative.





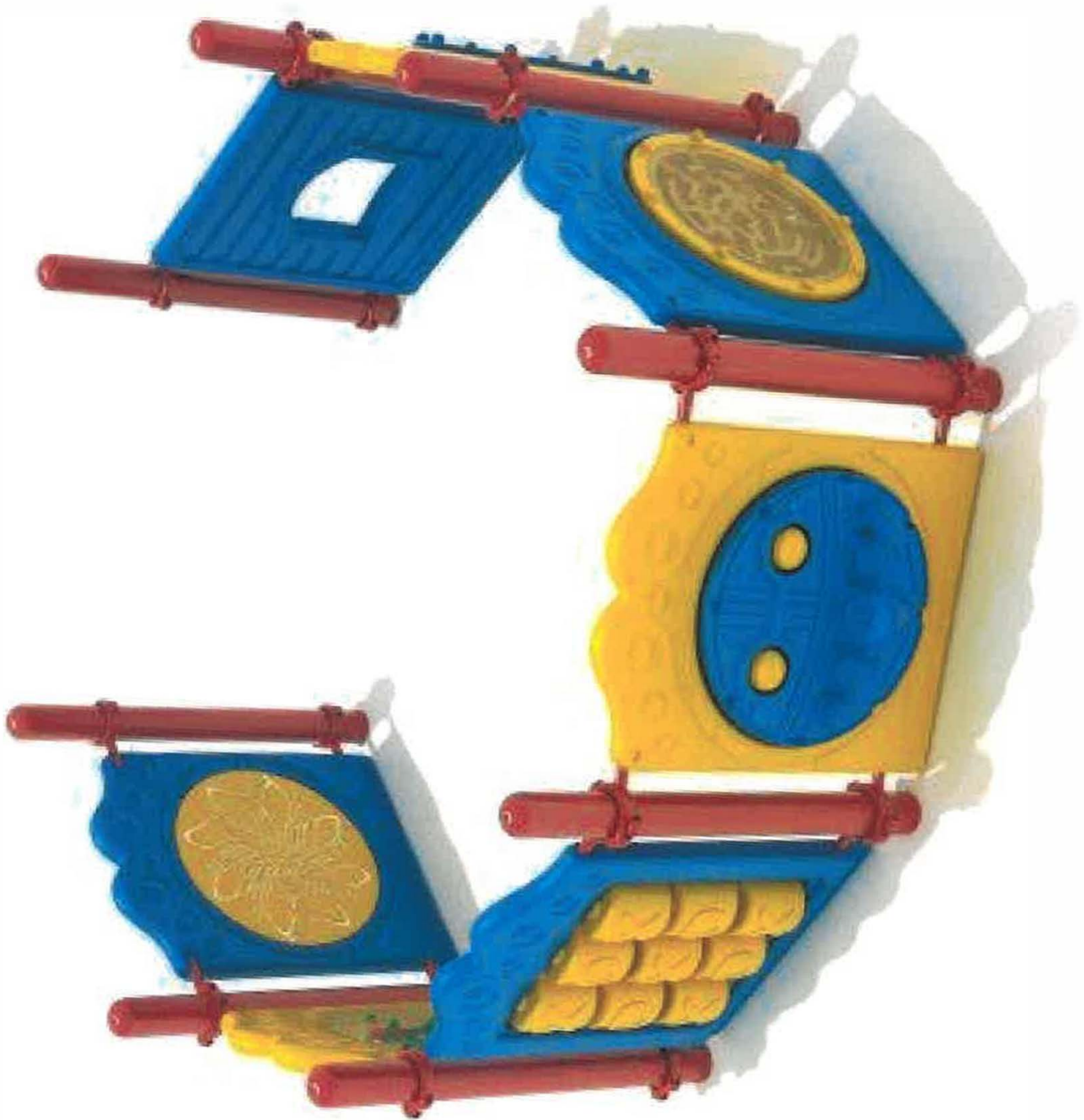





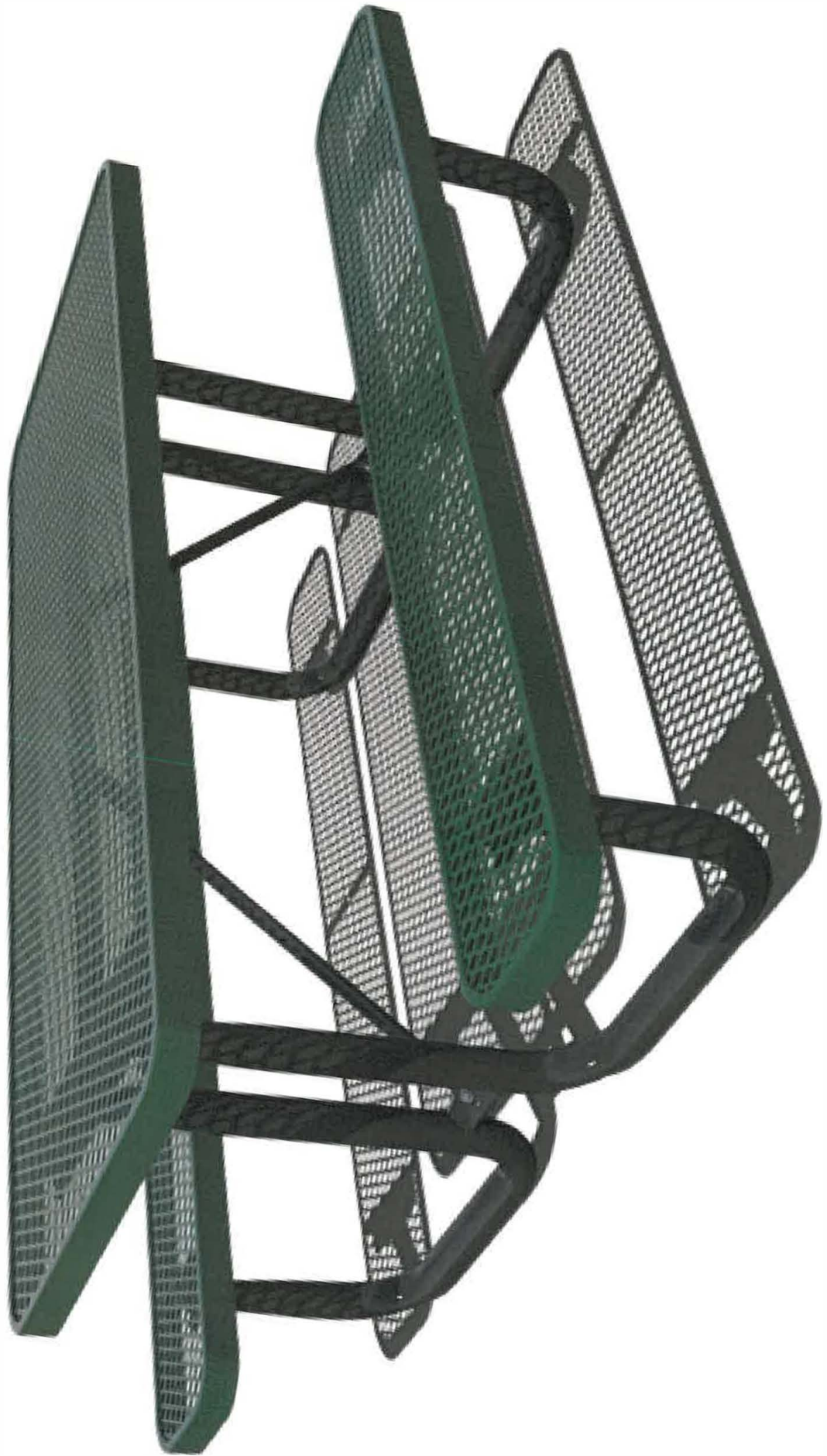

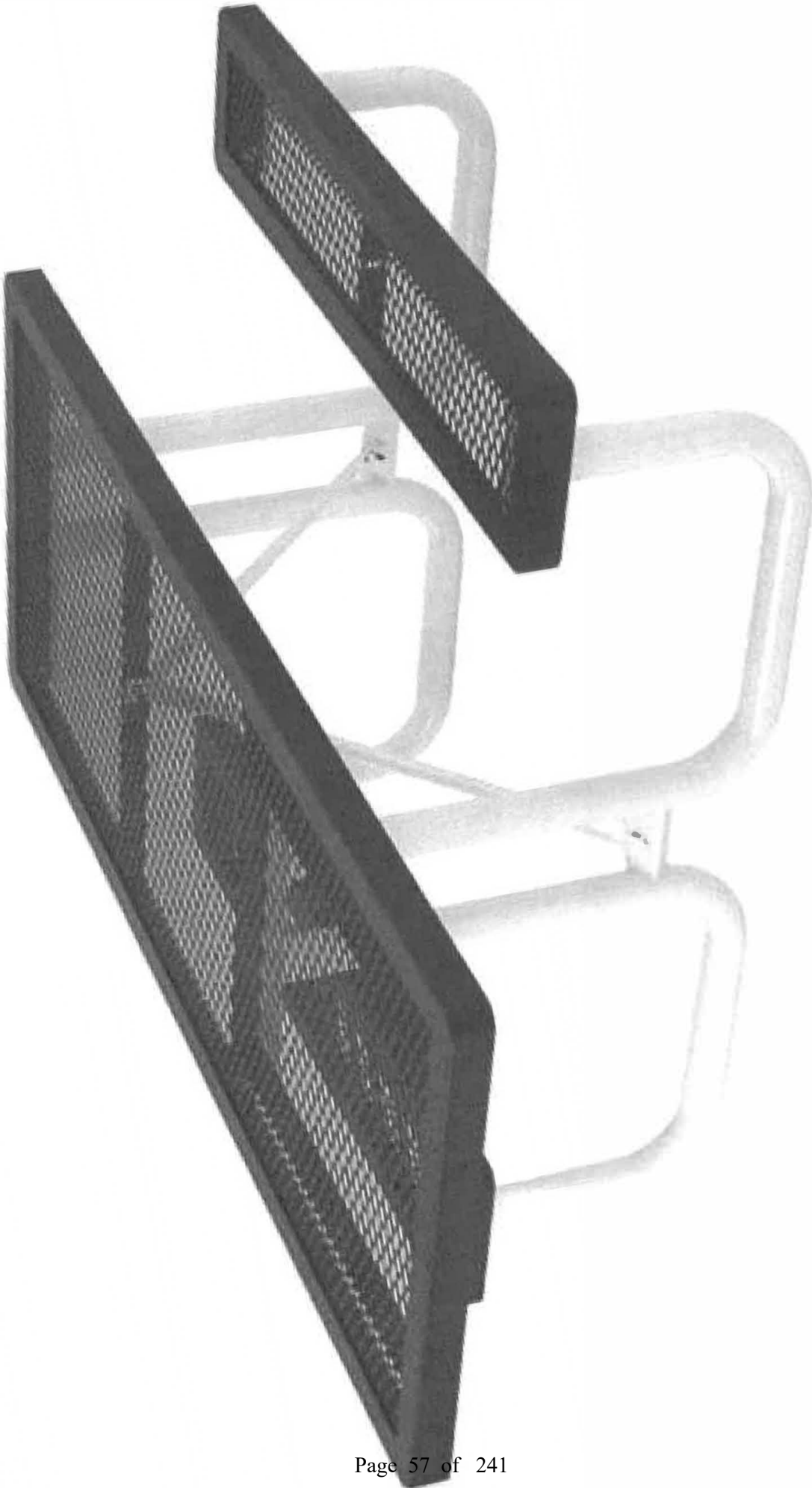

Hip Shade

Length	30'	Width	24'	Entry Height	10'
Peak Height	14.85'	Elbow	Glide	Column Mount	Embedded
Column Size	Ø5.5" Sch-40	Rafter Size	Ø3.5" 11-Ga	Ridge Size	Ø3.5" 11-Ga
Column Length	13'	Rafter Length	17.06'	Ridge Length	7.76'
Dome Qty.	1	Column Qty.	4		

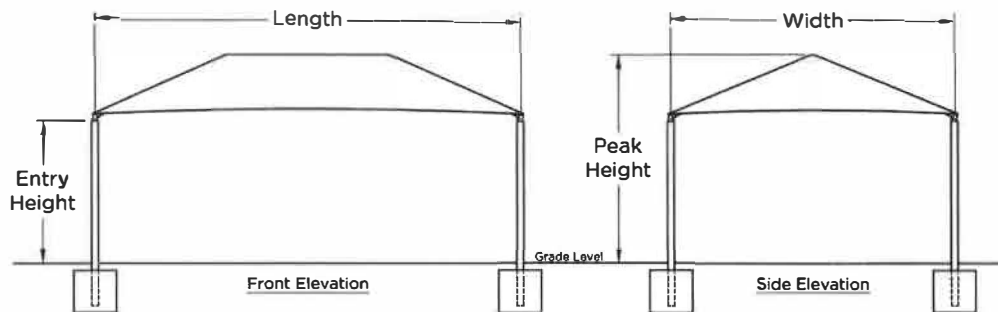
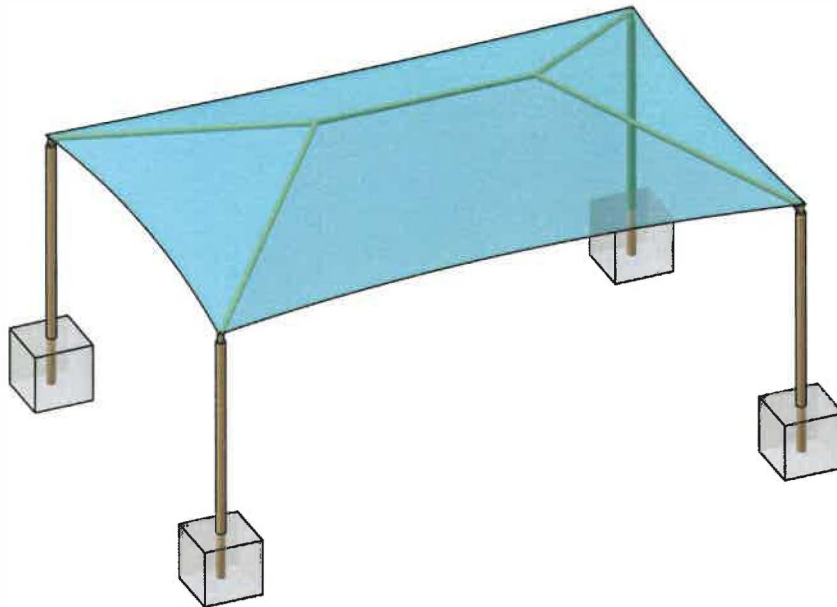

Square Footing		
Column	Length & Width	Depth
Single Cap	3.52	3
Double Cap	N/A	3

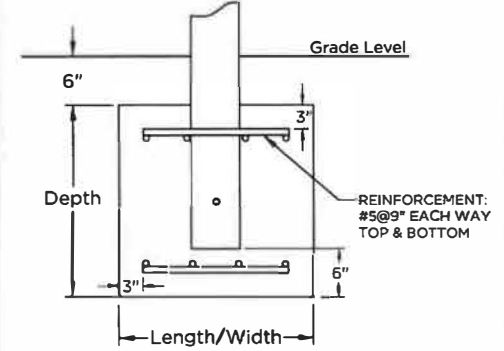

Auger Footing		
Diameter	Single Cap Depth	Double Cap Depth
1'-6"		
2'-0"	Out of range	N/A
2'-6"	Out of range	N/A
3'-0"	4.2	N/A

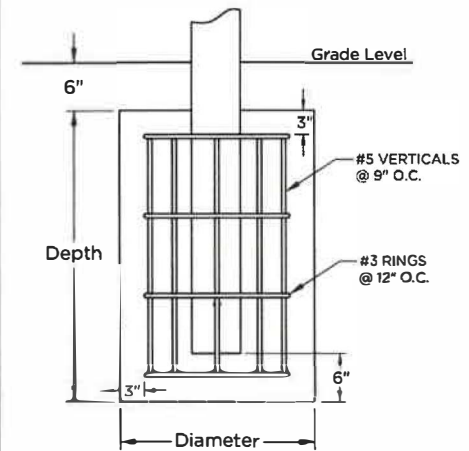

SuperiorShade

QUOTE

SHADE SIZE

30 X 24

SHADE STYLE

Hip Shade

These drawings are for reference only and should not be used as construction details. They show the general character and rough dimensions of the structural features. Exact spans, fasteners, materials, and foundations can be determined by a licensed professional engineer upon request. Estimated footing size above is based on 1,500 PSF soil bearing pressure.

Hip Shade

Length	45'	Width	28'	Entry Height	15'
Peak Height	20.65'	Elbow	Standard	Column Mount	Base Plate
Column Size	10"x10"x1/4"	Rafter Size	Ø5.0" 7-Ga	Ridge Size	Ø5.0" 7-Ga
Column Length	15.5'	Rafter Length	19.91'	Ridge Length	19.06'
Dome Qty.	1	Column Qty.	4		

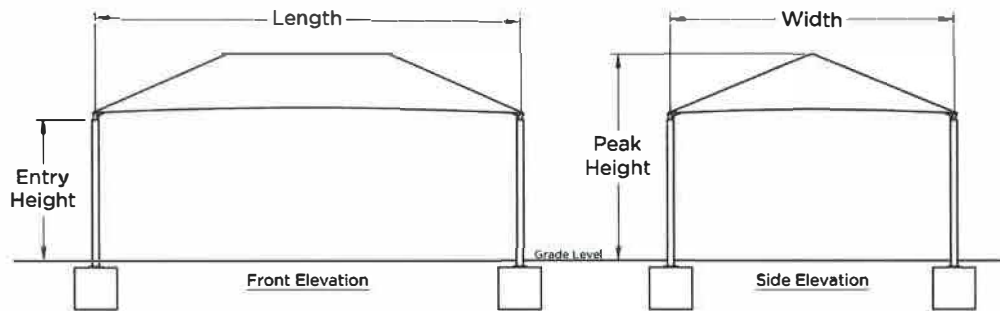
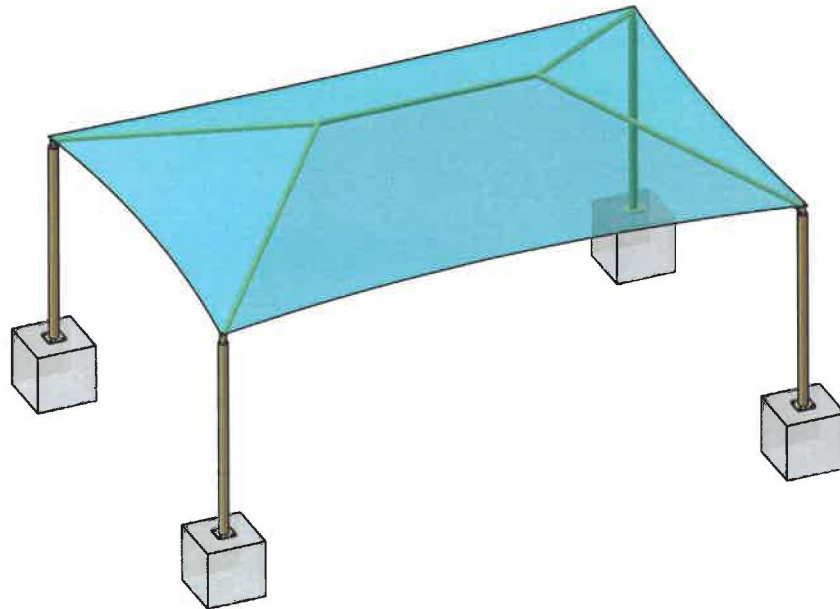

Square Footing		
Column	Length & Width	Depth
Single Cap	5.63	3
Double Cap	N/A	3

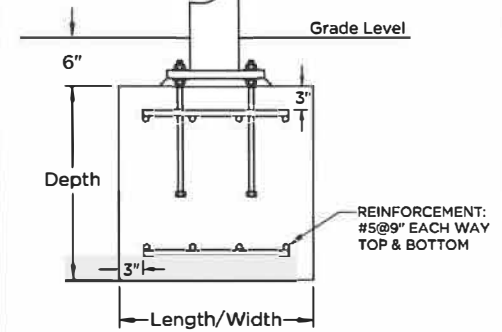

Auger Footing		
Diameter	Single Cap Depth	Double Cap Depth
1'-6"		
2'-0"	Out of range	N/A
2'-6"	Out of range	N/A
3'-0"	10.78	N/A

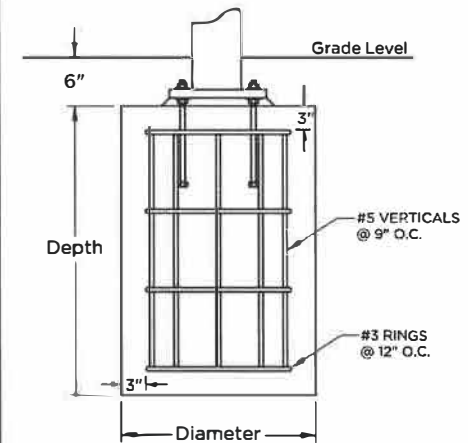

Superior Shade

QUOTE

SHADE SIZE

45 X 28

SHADE STYLE

Hip Shade

These drawings are for reference only and should not be used as construction details. They show the general character and rough dimensions of the structural features. Exact spans, fasteners, materials, and foundations can be determined by a licensed professional engineer upon request. Estimated footing size above is based on 1,500 PSF soil bearing pressure.

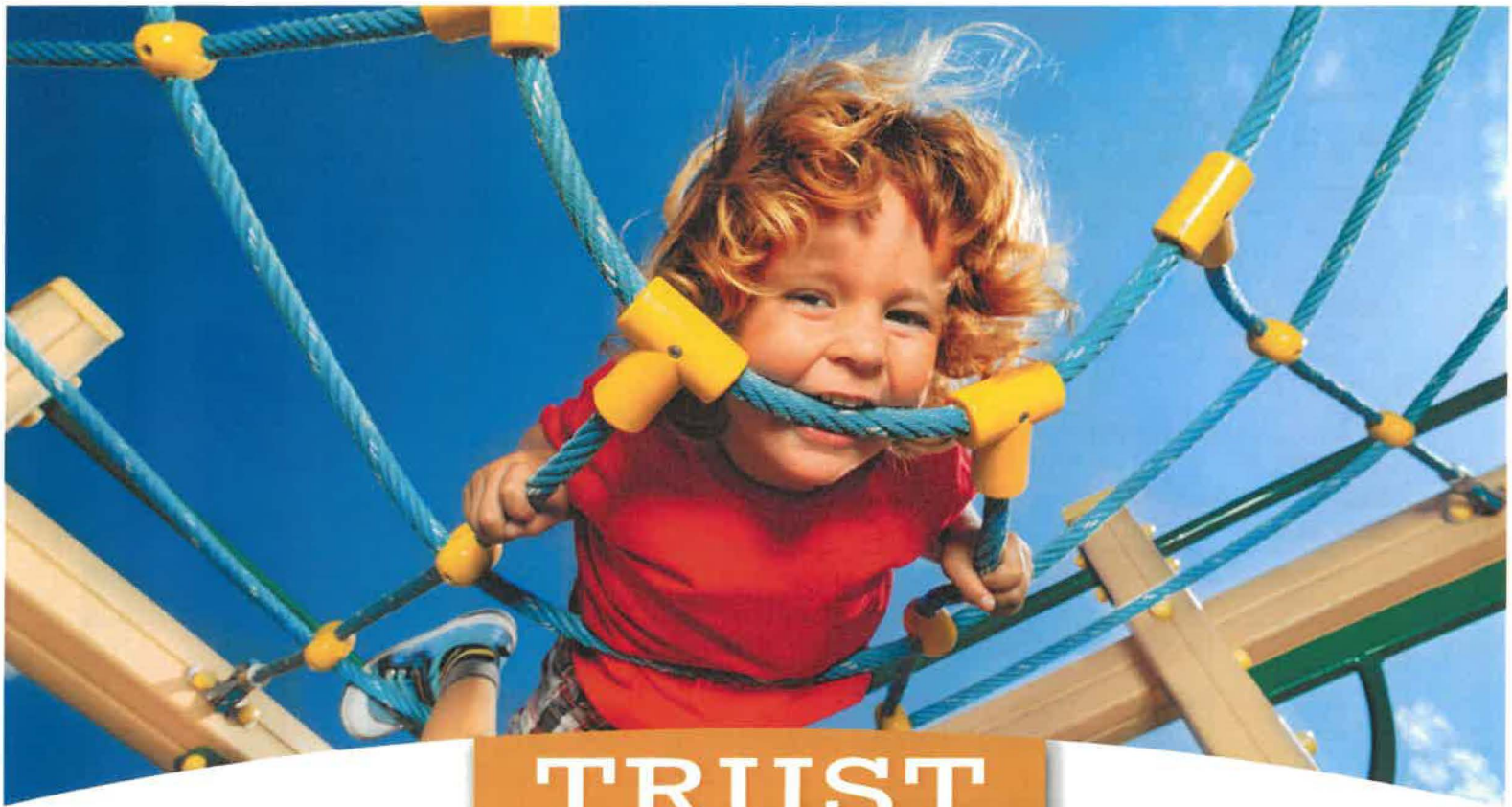

TRUST — the — EXPERTS

For over a decade, our customers have entrusted us to provide safe and affordable playground and recreational equipment. Our team of Certified General Contractors and Playground Safety Inspectors will insure that your project is completed to perfection, providing truly turnkey service, with every step of the process from planning and budgeting, through the installation being handled under one roof.



1-800-573-7529 | www.proplaygrounds.com



Pro Playgrounds
 8490 Cabin Hill Road
 Tallahassee, FL 32311

Quote

Date	Estimate #
9/15/2023	22061

Project Name
Gadsden County SD - Greensbor...



Customer / Bill To
Gadsden County School District Tammy McGriff 35 Martin Luther King Blvd Quincy, FL 32351

Ship To
Greensboro Elementary Johnny Riley 559 Greensboro Highway Quincy, FL 32351



WE WILL BEAT ANY PRICE BY 5%!

Item	Description	Qty	Cost	Total:
	Furnish labor and materials to: **GENERAL SCOPE OF WORK** 1.) Remove 7,325 square feet existing wood mulch and borders 2.) Remove existing playground equipment a.) 1 funnel ball game b.) 1x overhead climber c.) 1x 2 deck playground system d.) 6 bays of swing sets e.) 1x climber 3.) Assemble 4x Portable Metal Outdoor Benches 4.) Assemble 1x Portable Picnic Table 5.) Assemble 1x Portable ADA Picnic Table **NOTES** -Total square footage is 2,585 **ELEMENTARY PLAYGROUND AREA SCOPE OF WORK** 1.) Install 1x Barrington Ridge Play System 2.) Install 1x 1 Bay 2 Cantilever Swing Set 3.) Install 1x Camp Walden Interactive Panels 4.) Install 37 tons of aggregate rock subbase 5.) Install 989 square feet of poured in place rubber			

AGREED AND ACCEPTED:
 If the above total price, scope of work, specifications, terms and conditions are acceptable, sign below indicating your acceptance and authorization for Pro Playgrounds to proceed with the work and/or sales transaction described in this quotation. Upon signature and payment in accordance with this quote, Pro Playgrounds will proceed with the work and/or sales transaction.

 Signature Name / Title Date

Subtotal:
Sales Tax: (7.5%)
Total:

Terms and Conditions - Price valid for 30 days and subject to change. 1. If installation is not included with your purchase, client will be responsible for coordinating, receiving and unloading of all goods, delivery drivers will not help unload goods. 2. Client will be responsible to inspect goods for defect, damage or missing parts, any deficiency or missing parts must be noted on delivery slip. 3. Client will be responsible for costs due to cancelled or missed delivery appointments. 4. Client has reviewed all items, colors and descriptions on this quote for accuracy and correctness. 5. If quote includes installation of goods, the installation is subject to the terms and conditions of Pro Playgrounds "Standard Installation Agreement" a copy of which may be obtained from your Sales Representative.

1-800-573-7529 | www.proplaygrounds.com



Pro Playgrounds
8490 Cabin Hill Road
Tallahassee, FL 32311

Quote

Date	Estimate #
9/15/2023	22061

Project Name
Gadsden County SD - Greensbor...



Customer / Bill To
Gadsden County School District Tammy McGriff 35 Martin Luther King Blvd Quincy, FL 32351

Ship To
Greensboro Elementary Johnny Riley 559 Greensboro Highway Quincy, FL 32351

WE WILL BEAT ANY PRICE BY 5%!

Item	Description	Qty	Cost	Total:
	<p>surfacing with a 2" SBR thickness (6' fall height compliance) with a 50% color tpv and 50% black tpv .5" granule mix (2.5" total rubber thickness) over an aggregate rock subbase.</p> <p>6.) Install 1,024 square feet of poured in place rubber surfacing with 3" SBR thickness (8' fall height compliance) with a 50% color tpv and 50% black tpv .5" granule mix (3.5" total rubber thickness) over an aggregate rock subbase.</p> <p>7.) Install 1x 45'x28'x15' Standard Hip Shade (on base plates)</p> <p>**NOTES**</p> <p>-Surfacing Area is 43'x23' - Playground -Surfacing Area is 32'x32' - Swing set -Total square footage is 2,013</p> <p>**PRE-K/KINDERGARTEN PLAYGROUND SCOPE OF WORK**</p> <p>1.) Install 1x Ketchum Playground System 2.) Install 10 tons of aggregate rock subbase. 3.) Install 572 square feet of poured in place rubber surfacing with a 1.5" SBR thickness (4' fall height compliance) with a 50% color tpv and 50% black tpv .5" granule mix (2" total rubber thickness) over an</p>			

<p>AGREED AND ACCEPTED: If the above total price, scope of work, specifications, terms and conditions are acceptable, sign below indicating your acceptance and authorization for Pro Playgrounds to proceed with the work and/or sales transaction described in this quotation. Upon signature and payment in accordance with this quote, Pro Playgrounds will proceed with the work and/or sales transaction.</p>	Subtotal:
	Sales Tax: (7.5%)
	Total:

Terms and Conditions - Price valid for 30 days and subject to change. 1. If installation is not included with your purchase, client will be responsible for coordinating, receiving and unloading of all goods, delivery drivers will not help unload goods. 2. Client will be responsible to inspect goods for defect, damage or missing parts, any deficiency or missing parts must be noted on delivery slip. 3. Client will be responsible for costs due to cancelled or missed delivery appointments. 4. Client has reviewed all items, colors and descriptions on this quote for accuracy and correctness. 5. If quote includes installation of goods, the installation is subject to the terms and conditions of Pro Playgrounds "Standard Installation Agreement" a copy of which may be obtained from your Sales Representative.

1-800-573-7529 | www.proplaygrounds.com



The Play & Recreation Experts

Pro Playgrounds
8490 Cabin Hill Road
Tallahassee, FL 32311

Quote

Date	Estimate #
9/15/2023	22061

Project Name
Gadsden County SD - Greensbor...



WE WILL BEAT ANY PRICE BY 5%!

Customer / Bill To
Gadsden County School District Tammy McGriff 35 Martin Luther King Blvd Quincy, FL 32351

Ship To
Greensboro Elementary Johnny Riley 559 Greensboro Highway Quincy, FL 32351

Item	Description	Qty	Cost	Total:
	aggregate rock subbase. 4.) Install 1x 30'x24'x10' Hip Shade with Glide (inground mount) **NOTES** -Surfacing area is 26'x22' -Total Square footage is 572 **PLAY EQUIPMENT**			
QS-23-PSW120...	1 Bay 2 Cantilevers - Frame w/ Hangers, 1 Bay Belt Seat Package, 1 Bay Bucket Package	1	1,699.00	1,699.00
23-PMF035	Barrington Ridge	1	36,839.00	36,839.00
QS-23-PKP025P	Camp Walden - Primary	1	5,913.00	5,913.00
	KINDERGARTEN/PRE-K PLAYGROUND			
23-PKP260	Ketchum	1	9,153.00	9,153.00
Shipping	Combined Shipping and Freight Charges	1	3,600.00	3,600.00
	SHADE/SHELTER			
22-RD243010IG	30'x24'x10' Height -INGROUND - WITH GLIDE - RECTANGLE	1	9,799.00	9,799.00
CSSD	Custom Shade Design - 45'x28'x15' Standard Hip Shade (on base plates)	1	21,199.00	21,199.00
Shipping	Combined Shipping and Freight Charges	1	1,188.55	1,188.55

AGREED AND ACCEPTED:
If the above total price, scope of work, specifications, terms and conditions are acceptable, sign below indicating your acceptance and authorization for Pro Playgrounds to proceed with the work and/or sales transaction described in this quotation. Upon signature and payment in accordance with this quote, Pro Playgrounds will proceed with the work and/or sales transaction.

_____/_____/_____
Signature Name / Title Date

Subtotal:
Sales Tax: (7.5%)
Total:

Terms and Conditions - Price valid for 30 days and subject to change. 1. If installation is not included with your purchase, client will be responsible for coordinating, receiving and unloading of all goods, delivery drivers will not help unload goods. 2. Client will be responsible to inspect goods for defect, damage or missing parts, any deficiency or missing parts must be noted on delivery slip. 3. Client will be responsible for costs due to cancelled or missed delivery appointments. 4. Client has reviewed all items, colors and descriptions on this quote for accuracy and correctness. 5. If quote includes installation of goods, the installation is subject to the terms and conditions of Pro Playgrounds "Standard Installation Agreement" a copy of which may be obtained from your Sales Representative.

1-800-573-7529 | www.proplaygrounds.com



Pro Playgrounds
8490 Cabin Hill Road
Tallahassee, FL 32311

Quote

Date	Estimate #
9/15/2023	22061



WE WILL BEAT ANY PRICE BY 5%!

Project Name
Gadsden County SD - Greensbor...



Customer / Bill To	Ship To
Gadsden County School District Tammy McGriff 35 Martin Luther King Blvd Quincy, FL 32351	Greensboro Elementary Johnny Riley 559 Greensboro Highway Quincy, FL 32351

Item	Description	Qty	Cost	Total:
SITE AMMENITIES				
22-T6ULHDCP	6' UltraLeisureAccessible Rectangular Portable Table*	1	1,199.00	1,199.00
22-T6UL	6' UltraLeisureRectangular Portable Table	1	1,099.00	1,099.00
22-B6WBULP	6' UltraLeisureStandard Bench with Back, Portable	4	599.00	2,396.00
Shipping	Combined Shipping and Freight Charges	1	1,366.60	1,366.60
SURFACING MATERIALS				
TPV-CT	Color TPV Granules T	55	106.11455	5,836.30
AROPT	PremArc Aromatic Binder-T Pail	8	188.50	1,508.00
ARODT	PremArc Aromatic T Binder Drum	6	1,741.57167	10,449.43
TPV-BT	Premium 1350 Black Granules T	55	37.88091	2,083.45
SBRT	SBR Buffings T	268	30.95239	8,295.24
Shipping	Combined Shipping and Freight Charges	1	2,520.00	2,520.00
RAW MATERIALS				
CC80	Concrete for Anchoring - Delivered Cost	104	8.40	873.60
FBLOCK	Footer Blocks	80	3.75	300.00
AGG	Locally sourced crushed aggregate base materials (ABC Crush and Run Typical)	7	45.00	315.00
RBAR5	No. 5 Rebar	950	1.25	1,187.50
RMC	Ready Mix Concrete 2500 PSI MIN	21	200.00	4,200.00
RENTALS, LABOR, AND INSTALLATION				
22-Rentals	Rentals Necessary for Installation	1	17,481.18	17,481.18

AGREED AND ACCEPTED:
If the above total price, scope of work, specifications, terms and conditions are acceptable, sign below indicating your acceptance and authorization for Pro Playgrounds to proceed with the work and/or sales transaction described in this quotation. Upon signature and payment in accordance with this quote, Pro Playgrounds will proceed with the work and/or sales transaction.

Signature _____ Name / Title _____ Date _____

Subtotal:
Sales Tax: (7.5%)
Total:

Terms and Conditions - Price valid for 30 days and subject to change. 1. If installation is not included with your purchase, client will be responsible for coordinating, receiving and unloading of all goods, delivery drivers will not help unload goods. 2. Client will be responsible to inspect goods for defect, damage or missing parts, any deficiency or missing parts must be noted on delivery slip. 3. Client will be responsible for costs due to cancelled or missed delivery appointments. 4. Client has reviewed all items, colors and descriptions on this quote for accuracy and correctness. 5. If quote includes installation of goods, the installation is subject to the terms and conditions of Pro Playgrounds "Standard Installation Agreement" a copy of which may be obtained from your Sales Representative.



Pro Playgrounds
8490 Cabin Hill Road
Tallahassee, FL 32311

Quote

Date	Estimate #
9/15/2023	22061

Project Name
Gadsden County SD - Greensbor...



Customer / Bill To
Gadsden County School District
Tammy McGriff
35 Martin Luther King Blvd
Quincy, FL 32351

Ship To
Greensboro Elementary
Johhny Riley
559 Greensboro Highway
Quincy, FL 32351

WE WILL BEAT ANY PRICE BY 5%!

Item	Description	Qty	Cost	Total:
LBR	Demolition and Removal	1	22,252.50	22,252.50
LBR	Equipment Installation Per Contract	1	31,253.60	31,253.60
LBR	Surfacing Installation Per Contract	1	9,860.35	9,860.35
DSC	Discount - Per Contract Equipment		-8,929.60	-8,929.60
DSC	Discount - Per Contract Surfacing		-2,817.25	-2,817.25
DSC	Discount - Additional		-8,121.45	-8,121.45

AGREED AND ACCEPTED:
If the above total price, scope of work, specifications, terms and conditions are acceptable, sign below indicating your acceptance and authorization for Pro Playgrounds to proceed with the work and/or sales transaction described in this quotation. Upon signature and payment in accordance with this quote, Pro Playgrounds will proceed with the work and/or sales transaction.

Signature _____ Name / Title _____ Date _____

Subtotal:	\$193,999.00
Sales Tax: (7.5%)	\$0.00
Total:	<u>\$193,999.00</u>

Terms and Conditions - Price valid for 30 days and subject to change. 1. If installation is not included with your purchase, client will be responsible for coordinating, receiving and unloading of all goods, delivery drivers will not help unload goods. 2. Client will be responsible to inspect goods for defect, damage or missing parts, any deficiency or missing parts must be noted on delivery slip. 3. Client will be responsible for costs due to cancelled or missed delivery appointments. 4. Client has reviewed all items, colors and descriptions on this quote for accuracy and correctness. 5. If quote includes installation of goods, the installation is subject to the terms and conditions of Pro Playgrounds "Standard Installation Agreement" a copy of which may be obtained from your Sales Representative.





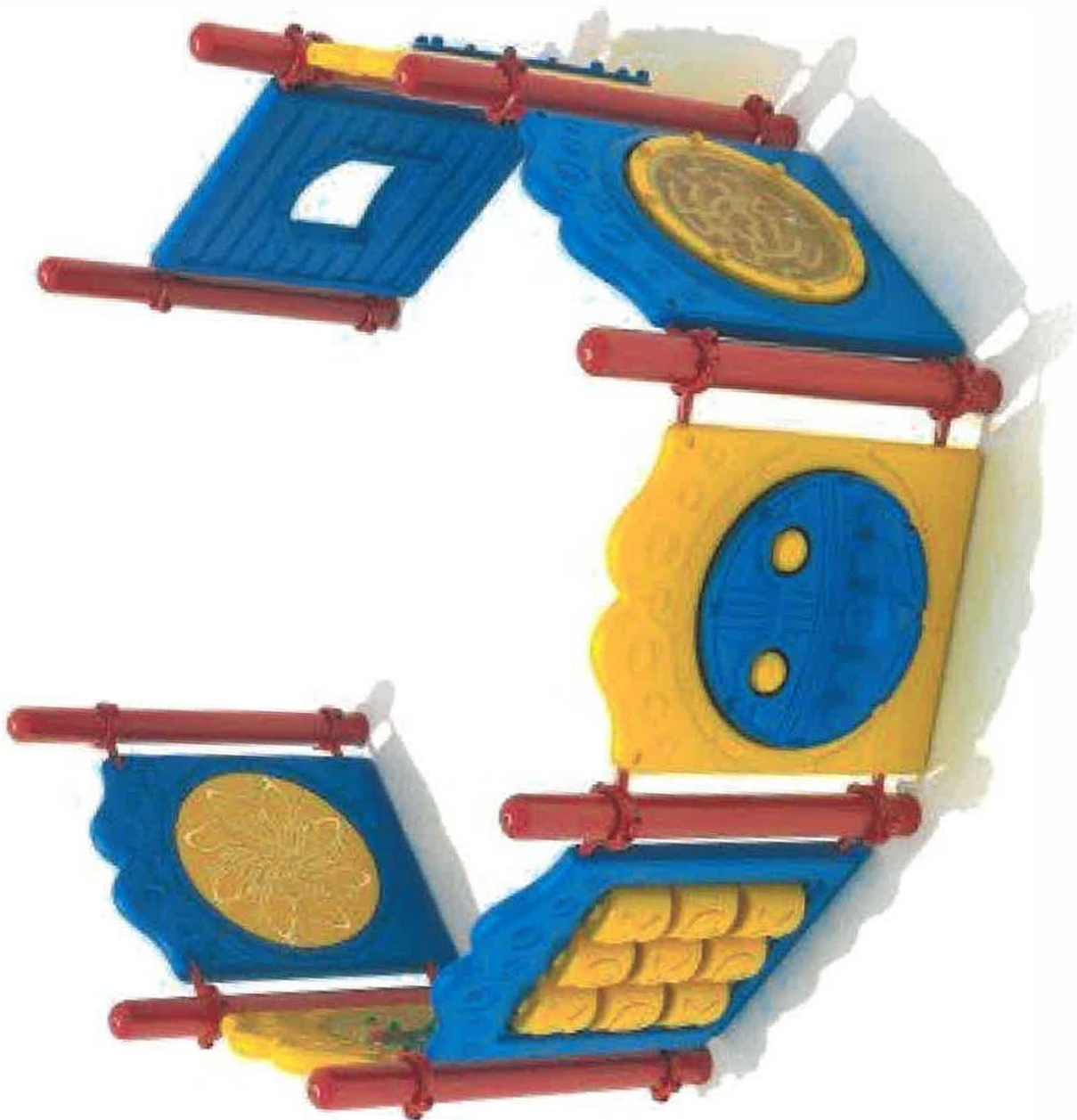







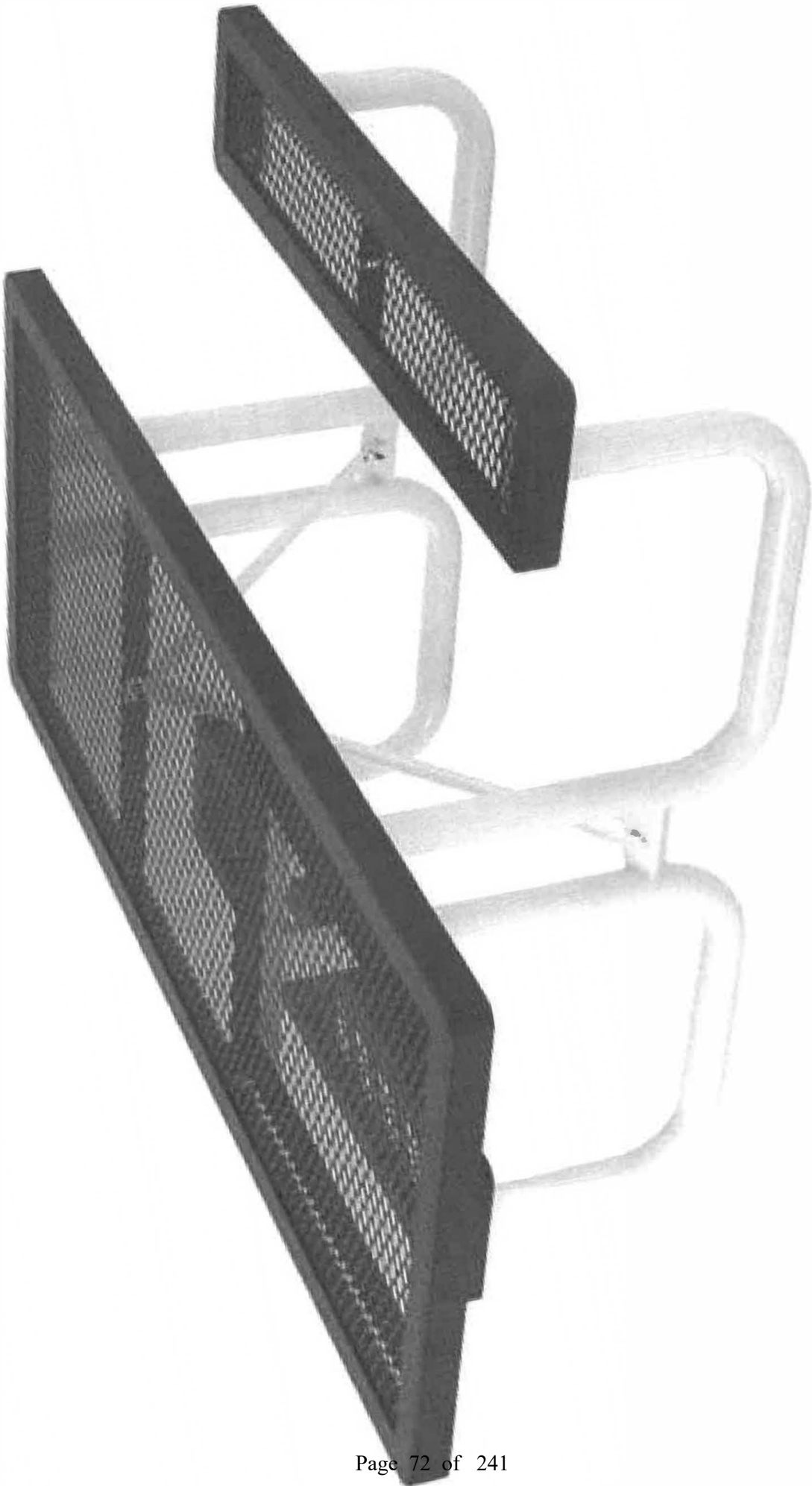

Hip Shade

Length	30'	Width	24'	Entry Height	10'
Peak Height	14.85'	Elbow	Glide	Column Mount	Embedded
Column Size	Ø5.5" Sch-40	Rafter Size	Ø3.5" 11-Ga	Ridge Size	Ø3.5" 11-Ga
Column Length	13'	Rafter Length	17.06'	Ridge Length	7.76'
Dome Qty.	1	Column Qty.	4		

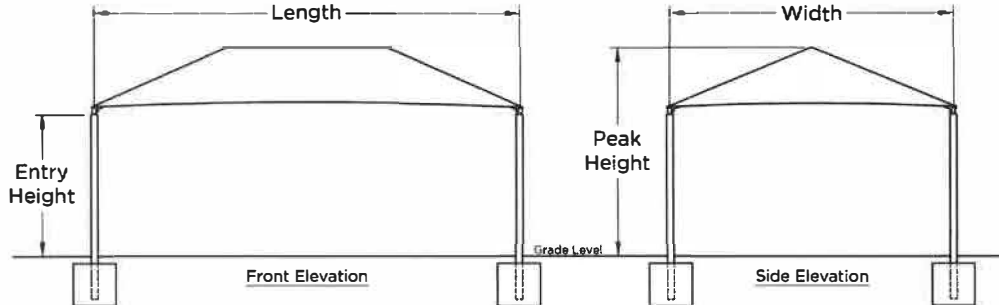
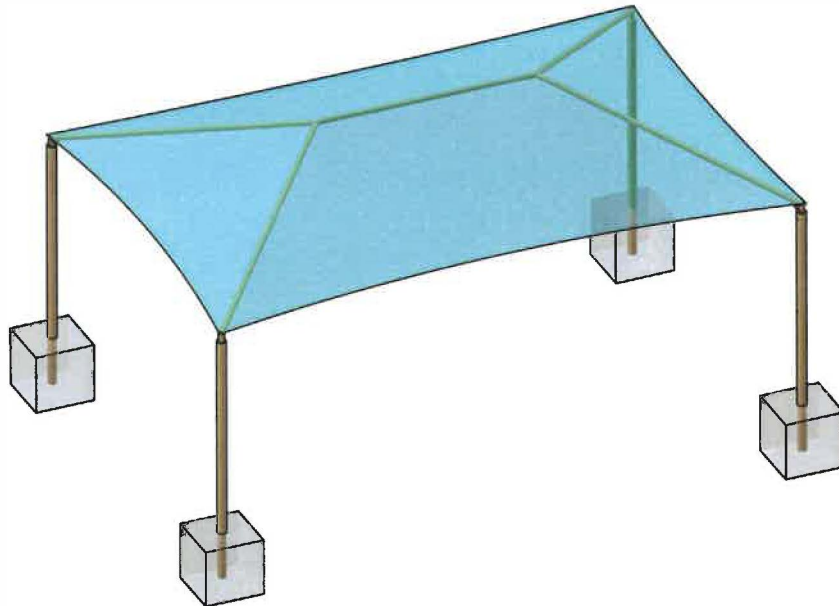

Square Footing		
Column	Length & Width	Depth
Single Cap	3.52	3
Double Cap	N/A	3

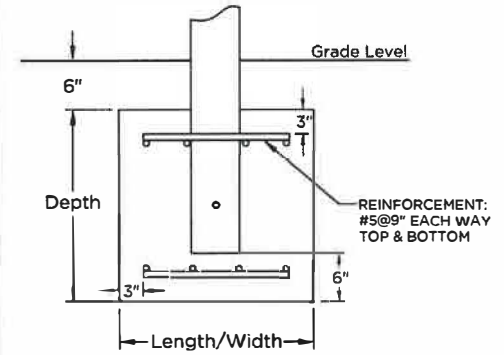

Auger Footing		
Diameter	Single Cap Depth	Double Cap Depth
1'-6"		
2'-0"	Out of range	N/A
2'-6"	Out of range	N/A
3'-0"	4.2	N/A

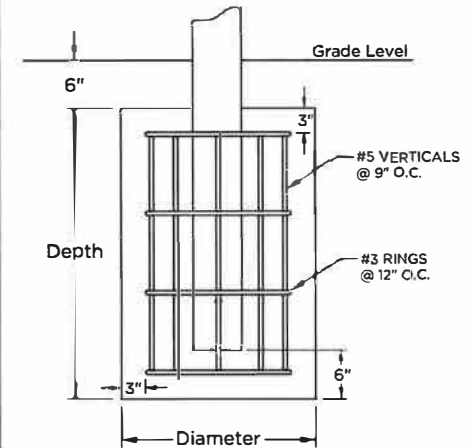

SuperiorShade

QUOTE

SHADE SIZE

30 X 24

SHADE STYLE

Hip Shade

These drawings are for reference only and should not be used as construction details. They show the general character and rough dimensions of the structural features. Exact spans, fasteners, materials, and foundations can be determined by a licensed professional engineer upon request. Estimated footing size above is based on 1,500 PSF soil bearing pressure.

Hip Shade

Length	45'	Width	28'	Entry Height	15'
Peak Height	20.65'	Elbow	Standard	Column Mount	Base Plate
Column Size	10"x10"x1/4"	Rafter Size	Ø5.0" 7-Ga	Ridge Size	Ø5.0" 7-Ga
Column Length	15.5'	Rafter Length	19.91'	Ridge Length	19.06'
Dome Qty.	1	Column Qty.	4		

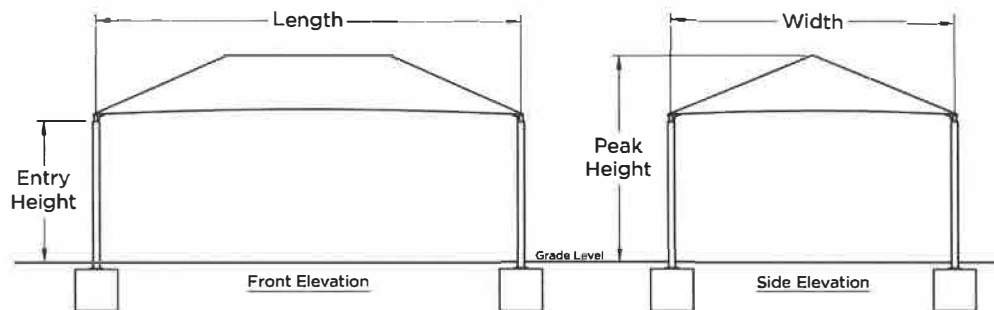
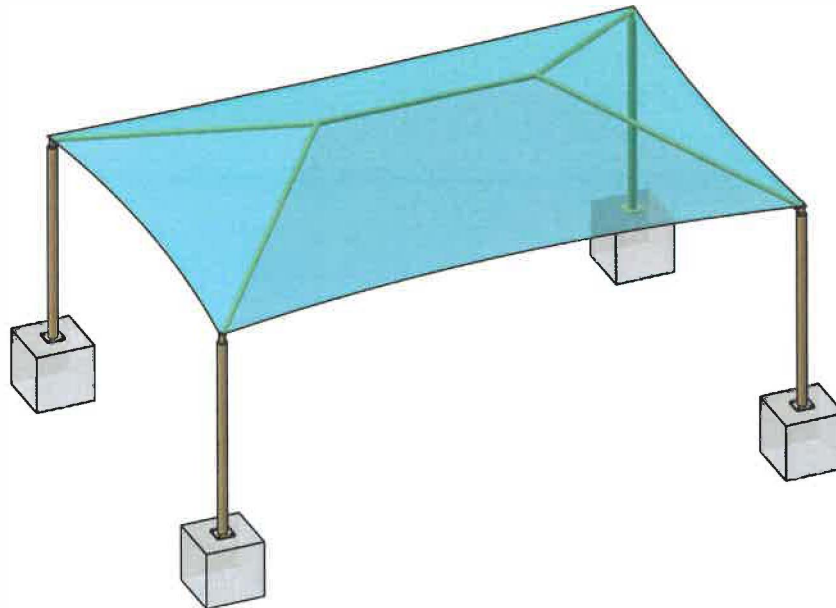

Square Footing		
Column	Length & Width	Depth
Single Cap	5.63	3
Double Cap	N/A	3

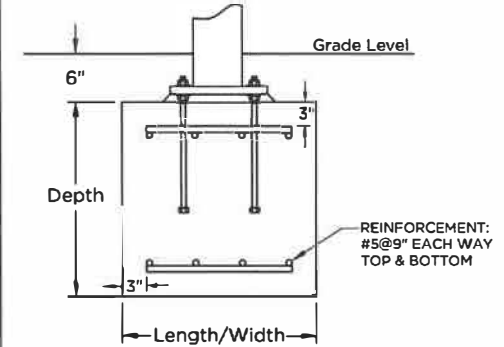

Auger Footing		
Diameter	Single Cap Depth	Double Cap Depth
1'-6"		
2'-0"	Out of range	N/A
2'-6"	Out of range	N/A
3'-0"	10.78	N/A

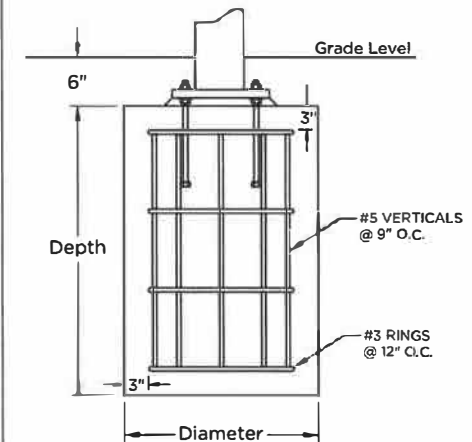

Superior Shade

QUOTE

SHADE SIZE

45 X 28

SHADE STYLE

Hip Shade

These drawings are for reference only and should not be used as construction details. They show the general character and rough dimensions of the structural features. Exact spans, fasteners, materials, and foundations can be determined by a licensed professional engineer upon request. Estimated footing size above is based on 1,500 PSF soil bearing pressure.

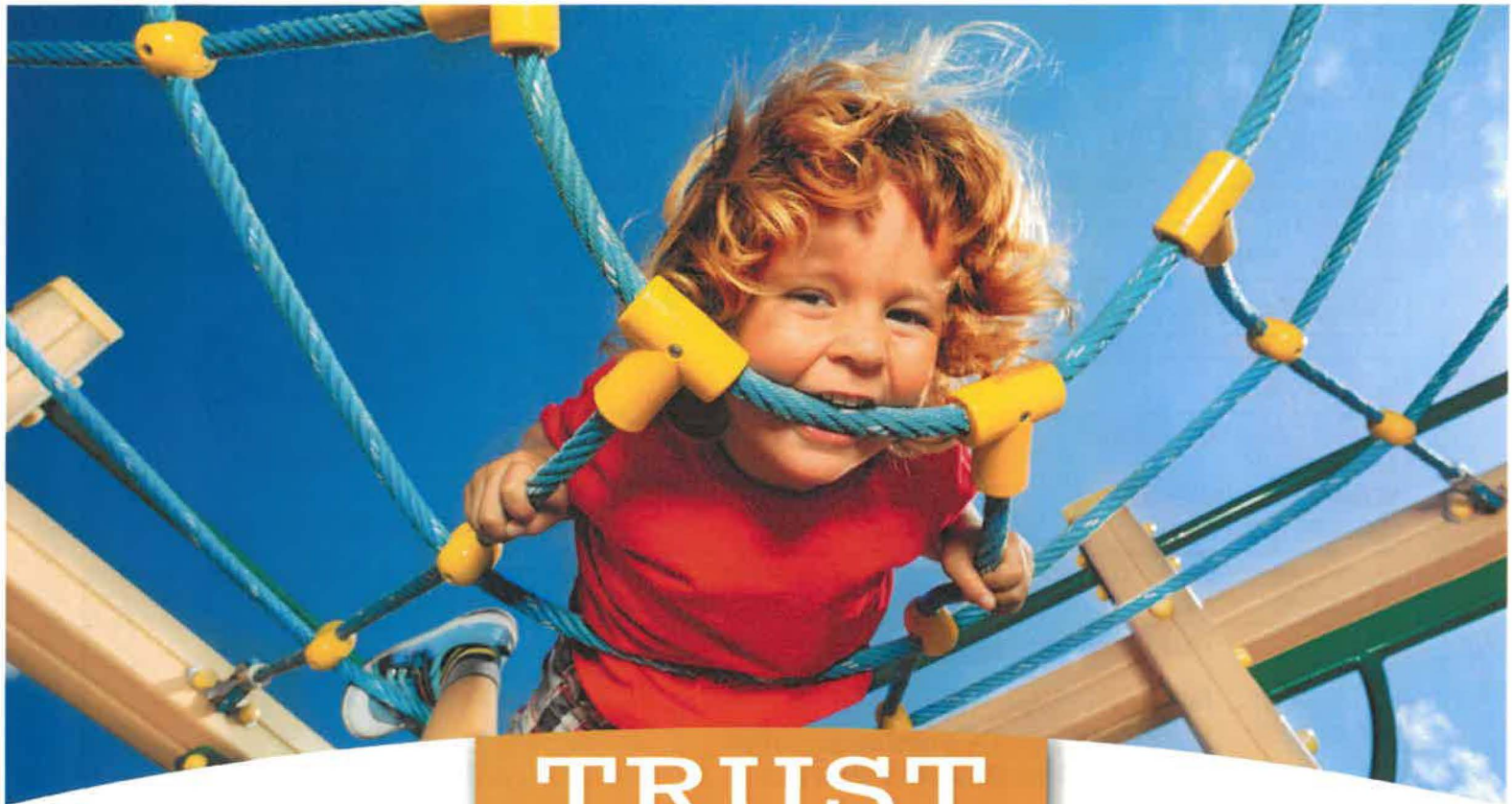

TRUST — *the* — EXPERTS

For over a decade, our customers have entrusted us to provide safe and affordable playground and recreational equipment. Our team of Certified General Contractors and Playground Safety Inspectors will insure that your project is completed to perfection, providing truly turnkey service, with every step of the process from planning and budgeting, through the installation being handled under one roof.



1-800-573-7529 | www.proplaygrounds.com



Pro Playgrounds
8490 Cabin Hill Road
Tallahassee, FL 32311

Quote

Date	Estimate #
9/15/2023	22063

Project Name
Gadsden County SD - Havana M...



Customer / Bill To
Gadsden County School District Tammy McGriff 35 Martin Luther King Blvd Quincy, FL 32351

Ship To
Gadsden County School District Tammy McGriff 35 Martin Luther King Blvd Quincy, FL 32351

WE WILL BEAT ANY PRICE BY 5%!

Item	Description	Qty	Cost	Total:
	<p>Furnish labor and materials to:</p> <p>**GENERAL SCOPE OF WORK</p> <p>1.) Remove Existing Playground Equipment from Kindergarten/Pre-K Playground and Big Kid's Playground</p> <p>a.) 1x Geodomes</p> <p>b.) 3 Bay Swing Set</p> <p>c.) 5x climbers</p> <p>d.) 1x 2-deck playground</p> <p>e.) 1x 4 seat see saw</p> <p>f.) 1x balance beam</p> <p>g.) 1x 1-deck playground</p> <p>2.) Remove existing borders and remnants of 10,300 square feet of wood mulch (most of the wood mulch is already gone)</p> <p>3.) Assemble 4x Portable Metal Outdoor Bench</p> <p>4.) Assemble 1x Portable Picnic Table</p> <p>5.) Assemble 1x Portable ADA Picnic Table</p> <p>**NOTES**</p> <p>-Total surfaced area is 3,153 square feet</p> <p>**BIG KIDS PLAYGROUND SCOPE OF WORK**</p> <p>1.) Install 1x Barrington Ridge Playground System</p>			

AGREED AND ACCEPTED:
If the above total price, scope of work, specifications, terms and conditions are acceptable, sign below indicating your acceptance and authorization for Pro Playgrounds to proceed with the work and/or sales transaction described in this quotation. Upon signature and payment in accordance with this quote, Pro Playgrounds will proceed with the work and/or sales transaction.

_____/_____/_____
Signature Name / Title Date

Subtotal:
Sales Tax: (7.5%)
Total:

Terms and Conditions - Price valid for 30 days and subject to change. 1. If installation is not included with your purchase, client will be responsible for coordinating, receiving and unloading of all goods, delivery drivers will not help unload goods. 2. Client will be responsible to inspect goods for defect, damage or missing parts, any deficiency or missing parts must be noted on delivery slip. 3. Client will be responsible for costs due to cancelled or missed delivery appointments. 4. Client has reviewed all items, colors and descriptions on this quote for accuracy and correctness. 5. If quote includes installation of goods, the installation is subject to the terms and conditions of Pro Playgrounds "Standard Installation Agreement" a copy of which may be obtained from your Sales Representative.



Pro Playgrounds
 8490 Cabin Hill Road
 Tallahassee, FL 32311

Quote

Date	Estimate #
9/15/2023	22063

Project Name
Gadsden County SD - Havana M...



Customer / Bill To
Gadsden County School District Tammy McGriff 35 Martin Luther King Blvd Quincy, FL 32351

Ship To
Gadsden County School District Tammy McGriff 35 Martin Luther King Blvd Quincy, FL 32351

WE WILL BEAT ANY PRICE BY 5%!

Item	Description	Qty	Cost	Total:
	2.) Install 1x Camp Walden Playground System 3.) Install 1x 2 Bay Arch Post Swing Set 4.) Install 39 tons of aggregate rock subbase 5.) Install 989 square feet of poured in place rubber surfacing with a 2" SBR thickness (6' fall height compliance) with a 50% color tpv and 50% black tpv .5" granule mix (2.5" total rubber thickness) over an aggregate rock subbase 6.) Install 1,152 square feet of poured in place rubber surfacing with a 3" SBR thickness (8' fall height compliance) with a 50% color tpv and 50% black tpv .5" granule mix (3.5" total rubber thickness) over an aggregate rock subbase 7.) Install 1x 45'x28'x15' Standard Hip Shade (on base plates) **NOTES** -Area is 36'x32' (swing set) -Area is 43'x23' (play system) -Total square footage is 2,141 **KINDERGARTEN/PRE-K PLAYGROUND SCOPE OF WORK** 1.) Install 1x Ketchum Playground System 2.) Install 1x T Swing			

AGREED AND ACCEPTED:
 If the above total price, scope of work, specifications, terms and conditions are acceptable, sign below indicating your acceptance and authorization for Pro Playgrounds to proceed with the work and/or sales transaction described in this quotation. Upon signature and payment in accordance with this quote, Pro Playgrounds will proceed with the work and/or sales transaction.

Signature _____ Name / Title _____ Date _____

Subtotal:
Sales Tax: (7.5%)
Total:

Terms and Conditions - Price valid for 30 days and subject to change. 1. If installation is not included with your purchase, client will be responsible for coordinating, receiving and unloading of all goods, delivery drivers will not help unload goods. 2. Client will be responsible to inspect goods for defect, damage or missing parts, any deficiency or missing parts must be noted on delivery slip. 3. Client will be responsible for costs due to cancelled or missed delivery appointments. 4. Client has reviewed all items, colors and descriptions on this quote for accuracy and correctness. 5. If quote includes installation of goods, the installation is subject to the terms and conditions of Pro Playgrounds "Standard Installation Agreement" a copy of which may be obtained from your Sales Representative.

1-800-573-7529 | www.proplaygrounds.com



Pro Playgrounds
 8490 Cabin Hill Road
 Tallahassee, FL 32311

Quote

Date	Estimate #
9/15/2023	22063

Project Name
Gadsden County SD - Havana M...



Customer / Bill To
Gadsden County School District Tammy McGriff 35 Martin Luther King Blvd Quincy, FL 32351

Ship To
Gadsden County School District Tammy McGriff 35 Martin Luther King Blvd Quincy, FL 32351

WE WILL BEAT ANY PRICE BY 5%!

Item	Description	Qty	Cost	Total:
	3.) Install 18 tons of aggregate rock subbase 4.) Install 572 square feet of poured in place rubber surfacing with a 1.5" SBR thickness (4' fall height compliance) with a 50% black tpv and 50% color tpv .5" granule mix (2" total rubber thickenss) over an aggregate rock subbase 5.) Install 440 square feet of poured in place rubber surfacing with a 3" SBR thickness (8' fall height compliance) with a 50% black tpv and 50% color tpv .5" granule mix (3.5" total rubber thickness) over an aggregate rock subbase. 6.) Install 1x 30'x24'x10' Hip Shade with Glide (embedded mount) **NOTES** -Area is 26'x22' (play system) -Area is 20'x22' (T swing) -Total square footage is 1,012 **BIG KIDS PLAYGROUND EQUIPMENT**			
23-PMF035	Barrington Ridge	1	36,839.00	36,839.00
QS-23-PSW006...	2 Bay - Frame w/ Hangers & 2 Bay Belt Seat Package	1	2,399.00	2,399.00
QS-23-PKP025P	Camp Walden - Primary	1	5,913.00	5,913.00

AGREED AND ACCEPTED:
 If the above total price, scope of work, specifications, terms and conditions are acceptable, sign below indicating your acceptance and authorization for Pro Playgrounds to proceed with the work and/or sales transaction described in this quotation. Upon signature and payment in accordance with this quote, Pro Playgrounds will proceed with the work and/or sales transaction.

 Signature Name / Title Date

Subtotal:
Sales Tax: (7.5%)
Total:

Terms and Conditions - Price valid for 30 days and subject to change. 1. If installation is not included with your purchase, client will be responsible for coordinating, receiving and unloading of all goods, delivery drivers will not help unload goods. 2. Client will be responsible to inspect goods for defect, damage or missing parts, any deficiency or missing parts must be noted on delivery slip. 3. Client will be responsible for costs due to cancelled or missed delivery appointments. 4. Client has reviewed all items, colors and descriptions on this quote for accuracy and correctness. 5. If quote includes installation of goods, the installation is subject to the terms and conditions of Pro Playgrounds "Standard Installation Agreement" a copy of which may be obtained from your Sales Representative.



Pro Playgrounds
8490 Cabin Hill Road
Tallahassee, FL 32311

Quote

Date	Estimate #
9/15/2023	22063

Project Name
Gadsden County SD - Havana M...



Customer / Bill To
Gadsden County School District Tammy McGriff 35 Martin Luther King Blvd Quincy, FL 32351

Ship To
Gadsden County School District Tammy McGriff 35 Martin Luther King Blvd Quincy, FL 32351

WE WILL BEAT ANY PRICE BY 5%!

Item	Description	Qty	Cost	Total:
	KINDERGARTEN/PRE-K PLAYGROUND EQUIPMENT			
23-PKP260	Ketchum	1	9,153.00	9,153.00
QS-23-PSW019...	2 Cantilevers - Frame w/ Hangers, 1 Bay Bucket Package	1	1,299.00	1,299.00
Shipping	Combined Shipping and Freight Charges	1	3,840.00	3,840.00
	SHADE/SHELTER			
CSSD	Custom Shade Design	1	21,199.00	21,199.00
22-RD243010IG	30'x24'x10' Height -INGROUND - WITH GLIDE - RECTANGLE	1	9,799.00	9,799.00
Shipping	Combined Shipping and Freight Charges	1	1,188.55	1,188.55
	SITE AMMENITIES			
22-B6WBULP	6' UltraLeisureStandard Bench with Back, Portable	4	599.00	2,396.00
22-T6UL	6' UltraLeisureRectangular Portable Table	1	1,099.00	1,099.00
22-T6ULHDCP	6' UltraLeisureAccessible Rectangular Portable Table*	1	1,199.00	1,199.00
Shipping	Combined Shipping and Freight Charges	1	1,366.60	1,366.60
	SURFACING MATERIALS			
TPV-BT	Premium 1350 Black Granules T	67	37.8809	2,538.02
TPV-CT	Color TPV Granules T	67	106.11448	7,109.67
SBRT	SBR Buffings T	322	30.95239	9,966.67
ARODT	PremArc Aromatic T Binder Drum	8	1,741.57125	13,932.57

<p>AGREED AND ACCEPTED: If the above total price, scope of work, specifications, terms and conditions are acceptable, sign below indicating your acceptance and authorization for Pro Playgrounds to proceed with the work and/or sales transaction described in this quotation. Upon signature and payment in accordance with this quote, Pro Playgrounds will proceed with the work and/or sales transaction.</p>	Subtotal:
	Sales Tax: (7.5%)
	Total:
<p>Signature _____ Name / Title _____ Date _____</p>	

Terms and Conditions - Price valid for 30 days and subject to change. 1. If installation is not included with your purchase, client will be responsible for coordinating, receiving and unloading of all goods, delivery drivers will not help unload goods. 2. Client will be responsible to inspect goods for defect, damage or missing parts, any deficiency or missing parts must be noted on delivery slip. 3. Client will be responsible for costs due to cancelled or missed delivery appointments. 4. Client has reviewed all items, colors and descriptions on this quote for accuracy and correctness. 5. If quote includes installation of goods, the installation is subject to the terms and conditions of Pro Playgrounds "Standard Installation Agreement" a copy of which may be obtained from your Sales Representative.

1-800-573-7529 | www.proplaygrounds.com



Pro Playgrounds
8490 Cabin Hill Road
Tallahassee, FL 32311

Quote

Date	Estimate #
9/15/2023	22063

Project Name
Gadsden County SD - Havana M...



Customer / Bill To
Gadsden County School District Tammy McGriff 35 Martin Luther King Blvd Quincy, FL 32351

Ship To
Gadsden County School District Tammy McGriff 35 Martin Luther King Blvd Quincy, FL 32351

WE WILL BEAT ANY PRICE BY 5%!

Item	Description	Qty	Cost	Total:
AROPT	PremArc Aromatic Binder-T Pail	2	188.50	377.00
Shipping	Combined Shipping and Freight Charges	1	3,000.00	3,000.00
RAW MATERIALS				
AGG	Locally sourced crushed aggregate base materials (ABC Crush and Run Typical)	57	45.00	2,565.00
FBLOCK	Footer Blocks	86	3.75	322.50
CC80	Concrete for Anchoring - Delivered Cost	140	8.40	1,176.00
RBAR5	No. 5 Rebar	950	1.25	1,187.50
RMC	Ready Mix Concrete 2500 PSI MIN	21	200.00	4,200.00
RENTALS, LABOR, AND INSTALLATION				
22-Rentals	Rentals Necessary for Installation	1	18,051.58	18,051.58
LBR	Labor and Installation for Removal of Playground and Surfacing	1	18,543.75	18,543.75
LBR	Equipment Installation Per Contract	1	32,431.00	32,431.00
LBR	Surfacing Installation Per Contract	1	11,873.38	11,873.38
DSC	Discount - Per Contract Equipment		-9,129.50	-9,129.50
DSC	Discount - Per Contract Surfacing		-3,392.39	-3,392.39
DSC	Discount - Additional		-12,443.90	-12,443.90

AGREED AND ACCEPTED:
If the above total price, scope of work, specifications, terms and conditions are acceptable, sign below indicating your acceptance and authorization for Pro Playgrounds to proceed with the work and/or sales transaction described in this quotation. Upon signature and payment in accordance with this quote, Pro Playgrounds will proceed with the work and/or sales transaction.

_____/_____/_____
Signature Name / Title Date

Subtotal:	\$199,999.00
Sales Tax: (7.5%)	\$0.00
Total:	<u>\$199,999.00</u>

Terms and Conditions - Price valid for 30 days and subject to change. 1. If installation is not included with your purchase, client will be responsible for coordinating, receiving and unloading of all goods, delivery drivers will not help unload goods. 2. Client will be responsible to inspect goods for defect, damage or missing parts, any deficiency or missing parts must be noted on delivery slip. 3. Client will be responsible for costs due to cancelled or missed delivery appointments. 4. Client has reviewed all items, colors and descriptions on this quote for accuracy and correctness. 5. If quote includes installation of goods, the installation is subject to the terms and conditions of Pro Playgrounds "Standard Installation Agreement" a copy of which may be obtained from your Sales Representative.

1-800-573-7529 | www.proplaygrounds.com



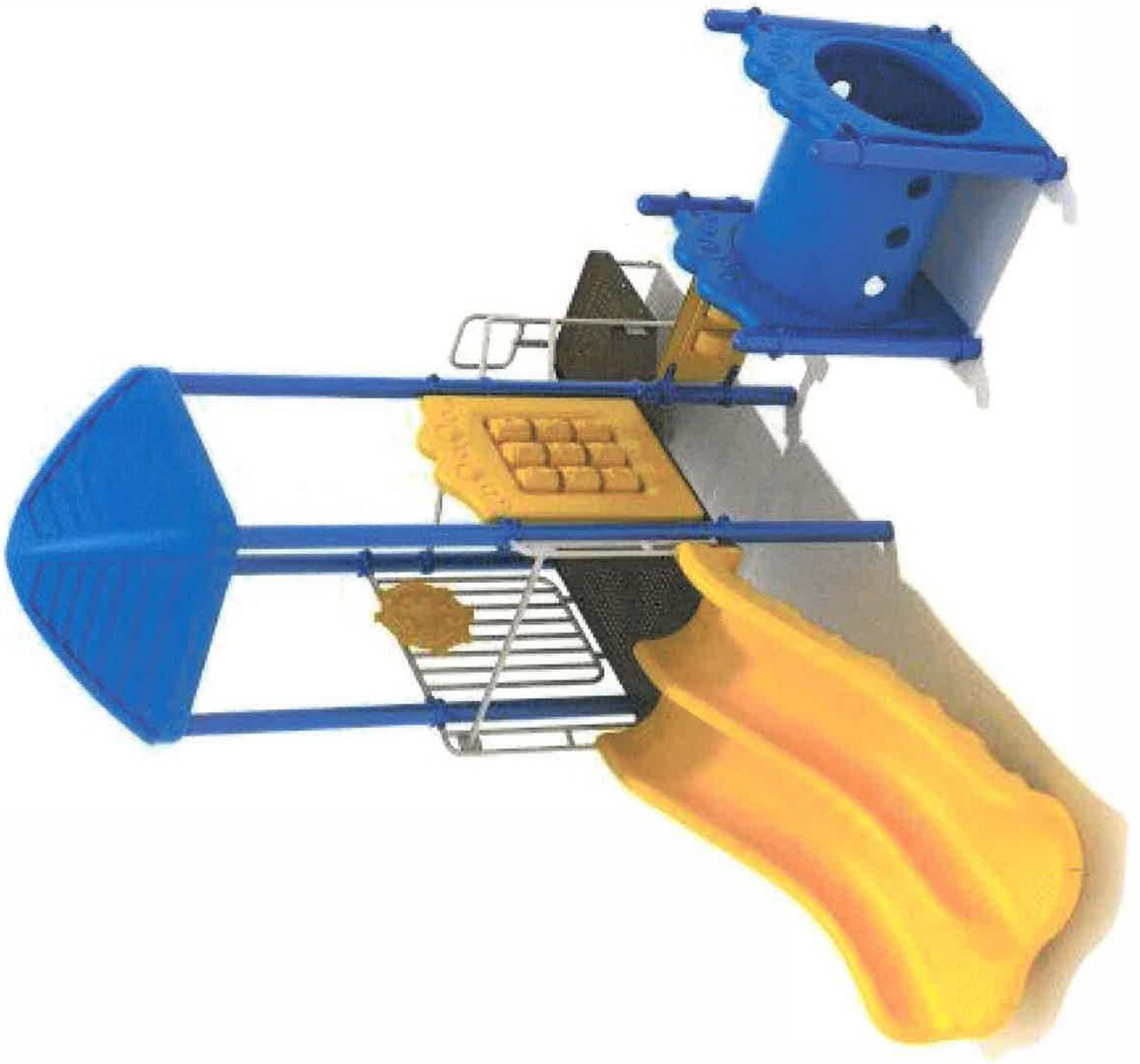

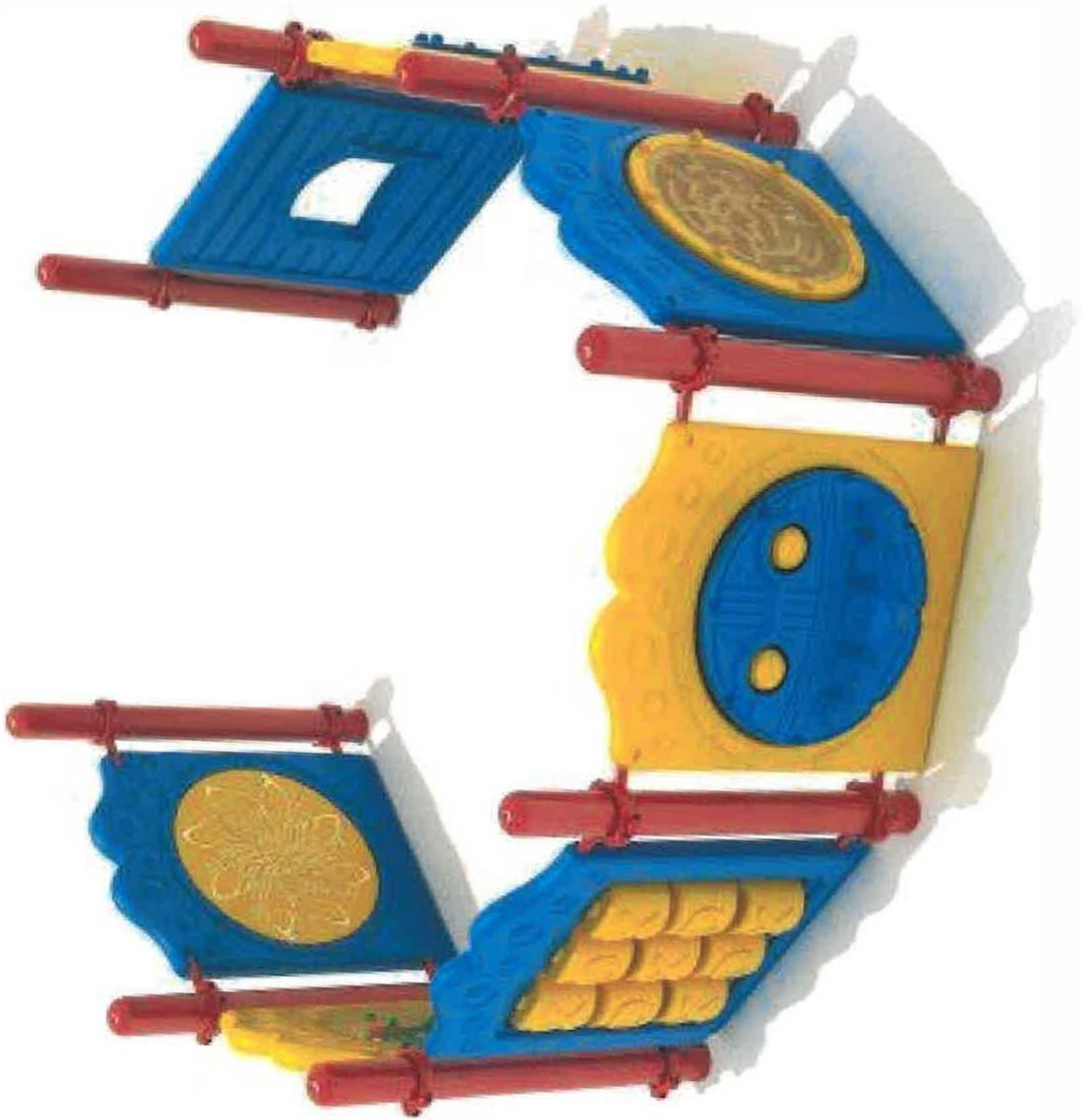









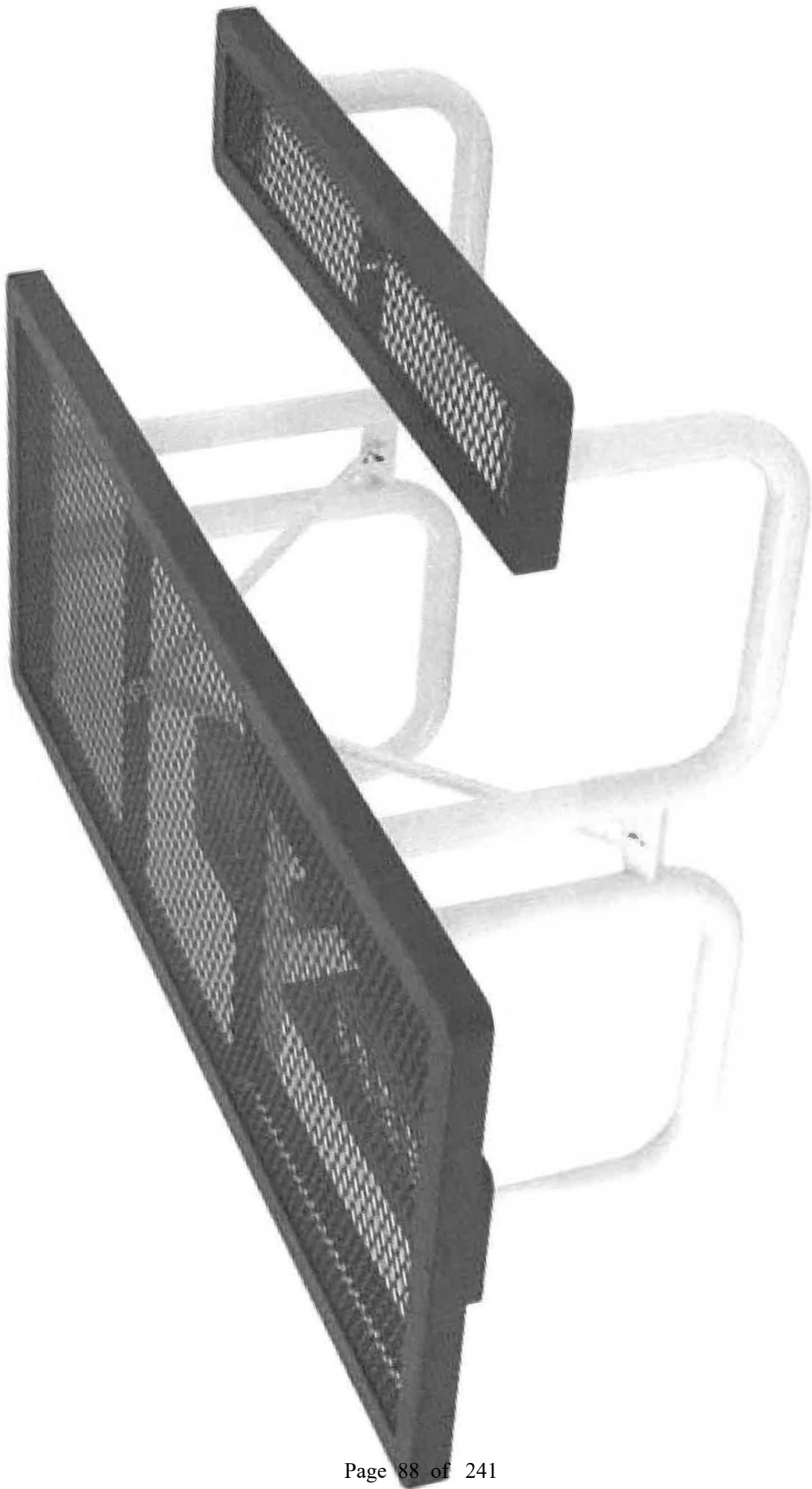

Hip Shade

Length	30'	Width	24'	Entry Height	10'
Peak Height	14.85'	Elbow	Glide	Column Mount	Embedded
Column Size	Ø5.5" Sch-40	Rafter Size	Ø3.5" 11-Ga	Ridge Size	Ø3.5" 11-Ga
Column Length	13'	Rafter Length	17.06'	Ridge Length	7.76'
Dome Qty.	1	Column Qty.	4		

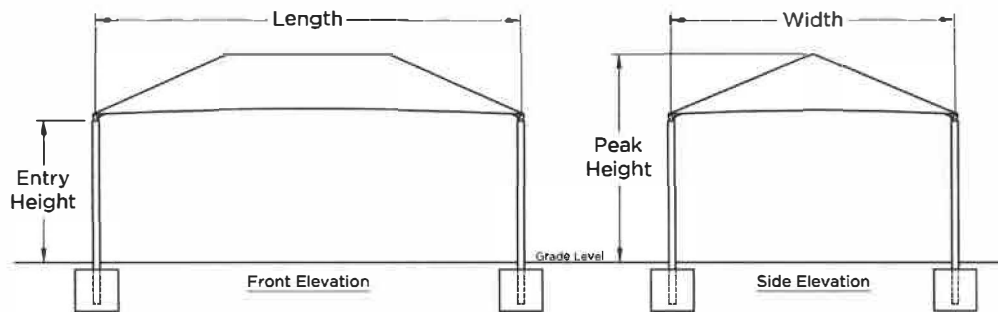
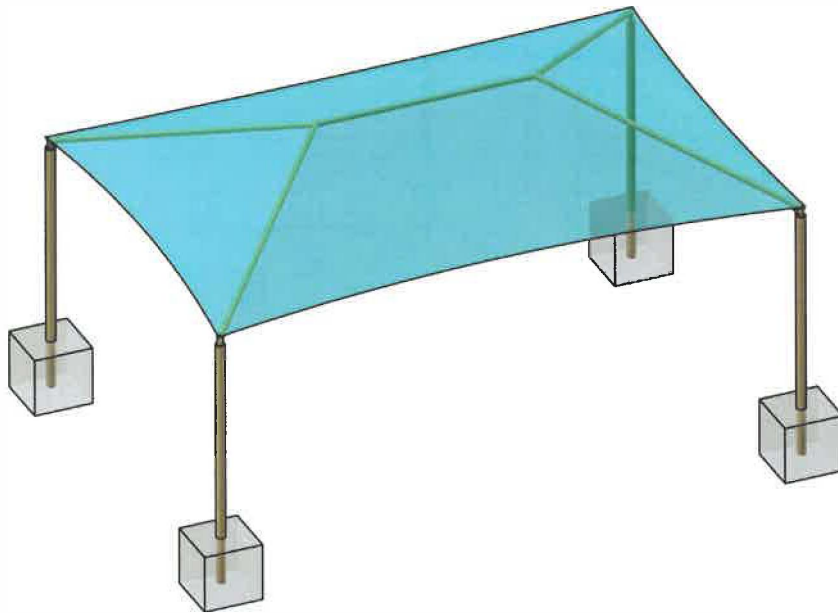

Column	Length & Width	Depth
Single Cap	3.52	3
Double Cap	N/A	3

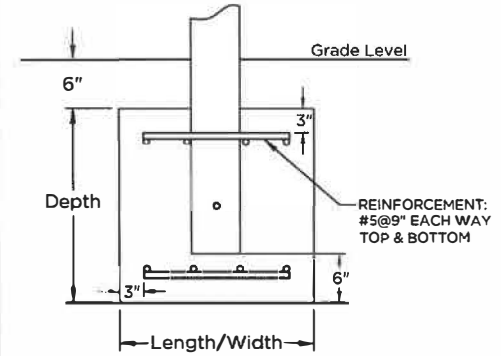

Diameter	Single Cap Depth	Double Cap Depth
1'-6"		
2'-0"	Out of range	N/A
2'-6"	Out of range	N/A
3'-0"	4.2	N/A

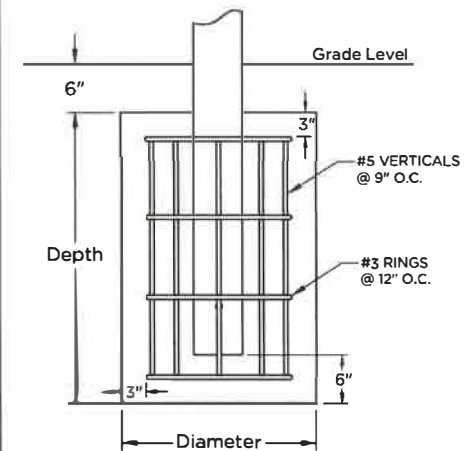

SuperiorShade

QUOTE

SHADE SIZE

30 X 24

SHADE STYLE

Hip Shade

These drawings are for reference only and should not be used as construction details. They show the general character and rough dimensions of the structural features. Exact spans, fasteners, materials, and foundations can be determined by a licensed professional engineer upon request. Estimated footing size above is based on 1,500 PSF soil bearing pressure.

Hip Shade

Length	45'	Width	28'	Entry Height	15'
Peak Height	20.65'	Elbow	Standard	Column Mount	Base Plate
Column Size	10"x10"x1/4"	Rafter Size	Ø5.0" 7-Ga	Ridge Size	Ø5.0" 7-Ga
Column Length	15.5'	Rafter Length	19.91'	Ridge Length	19.06'
Dome Qty.	1	Column Qty.	4		

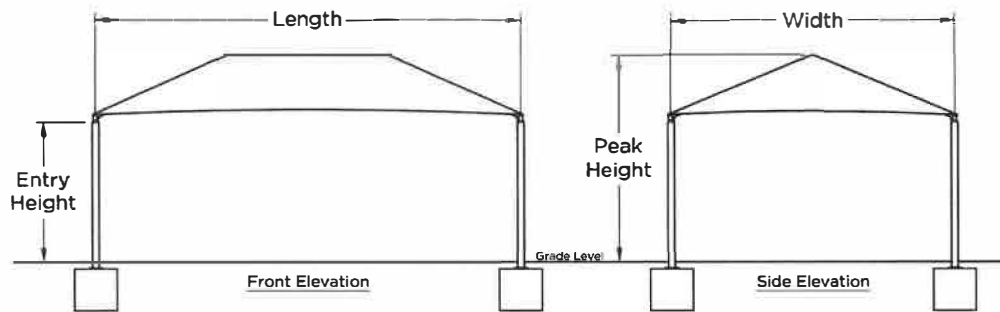
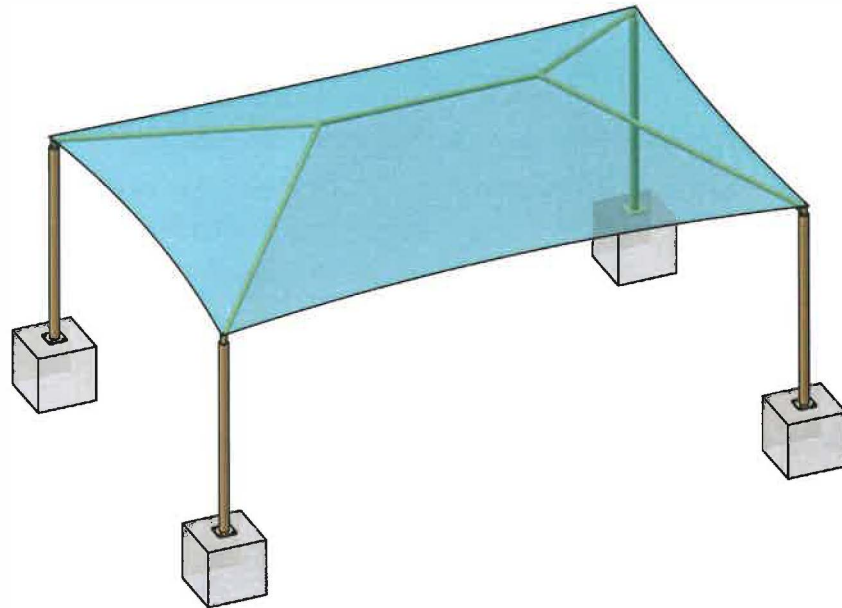

Square Footing		
Column	Length & Width	Depth
Single Cap	5.63	3
Double Cap	N/A	3

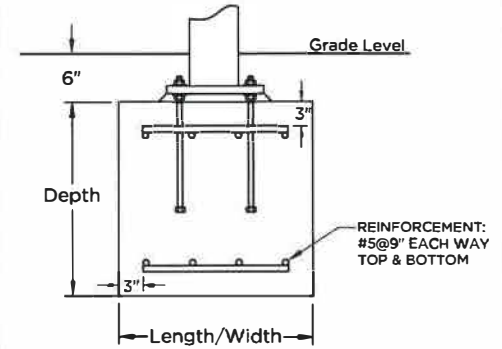

Auger Footing		
Diameter	Single Cap Depth	Double Cap Depth
1'-6"		
2'-0"	Out of range	N/A
2'-6"	Out of range	N/A
3'-0"	10.78	N/A

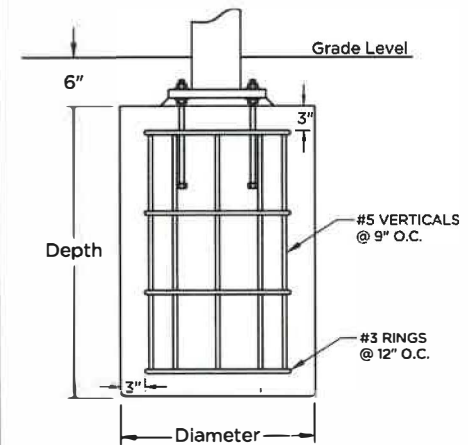

Superior Shade

QUOTE

SHADE SIZE

45 X 28

SHADE STYLE

Hip Shade

These drawings are for reference only and should not be used as construction details. They show the general character and rough dimensions of the structural features. Exact spans, fasteners, materials, and foundations can be determined by a licensed professional engineer upon request. Estimated footing size above is based on 1,500 PSF soil bearing pressure.

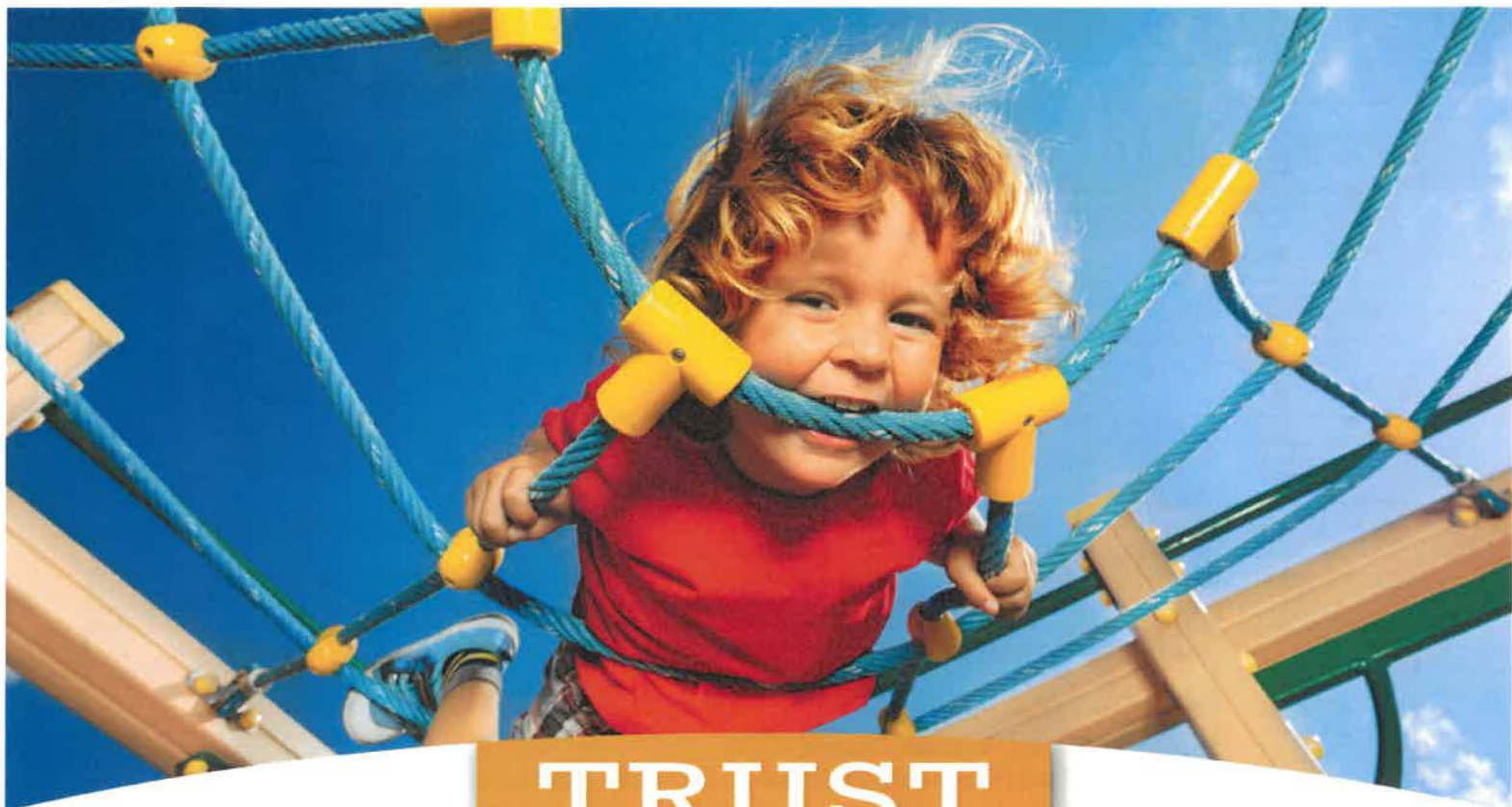

TRUST — the — EXPERTS

For over a decade, our customers have entrusted us to provide safe and affordable playground and recreational equipment. Our team of Certified General Contractors and Playground Safety Inspectors will insure that your project is completed to perfection, providing truly turnkey service, with every step of the process from planning and budgeting, through the installation being handled under one roof.



1-800-573-7529 | www.proplaygrounds.com



The Play & Recreation Experts

Pro Playgrounds
8490 Cabin Hill Road
Tallahassee, FL 32311

Quote

Date	Estimate #
9/14/2023	22029

Project Name
Gadsden County SD - Stewart St...



Customer / Bill To
Gadsden County School District Tammy McGriff 35 Martin Luther King Blvd Quincy, FL 32351

Ship To
Stewart Street Elementary Johnny Riley 749 South Stewart Street Quincy, FL 32351

WE WILL BEAT ANY PRICE BY 5%!

Item	Description	Qty	Cost	Total:
	Furnish labor and materials to: **GENERAL SCOPE OF WORK 1.) Remove Existing Playground Equipment from Kindergarten/Pre-K Playground and Big Kid's Playground a.) 2 Geodomes b.) 4 Bay Wooden Swing Set c.) 3 Inground Tether Ball Systems d.) 17 inground tires e.) 12 inground wooden posts f.) 1 inground wooden bench with shade g.) 2 climbers h.) 1 3-deck playground system 2.) Remove existing borders and remnants of 20,000 square feet of wood mulch (most of the wood mulch is already gone) 3.) Assemble 4x Portable Metal Outdoor Bench 4.) Assemble 1x Portable Picnic Table 5.) Assemble 1x Portable ADA Picnic Table **NOTES** -Total surfaced area is 3,153 square feet **BIG KIDS PLAYGROUND SCOPE OF WORK**			

AGREED AND ACCEPTED:		
If the above total price, scope of work, specifications, terms and conditions are acceptable, sign below indicating your acceptance and authorization for Pro Playgrounds to proceed with the work and/or sales transaction described in this quotation. Upon signature and payment in accordance with this quote, Pro Playgrounds will proceed with the work and/or sales transaction.		
Signature	Name / Title	Date

Subtotal:
Sales Tax: (7.5%)
Total:

Terms and Conditions - Price valid for 30 days and subject to change. 1. If installation is not included with your purchase, client will be responsible for coordinating, receiving and unloading of all goods, delivery drivers will not help unload goods. 2. Client will be responsible to inspect goods for defect, damage or missing parts, any deficiency or missing parts must be noted on delivery slip. 3. Client will be responsible for costs due to cancelled or missed delivery appointments. 4. Client has reviewed all items, colors and descriptions on this quote for accuracy and correctness. 5. If quote includes installation of goods, the installation is subject to the terms and conditions of Pro Playgrounds "Standard Installation Agreement" a copy of which may be obtained from your Sales Representative.

1-800-573-7529 | www.proplaygrounds.com



The Play & Recreation Experts

Pro Playgrounds
8490 Cabin Hill Road
Tallahassee, FL 32311

Quote

Date	Estimate #
9/14/2023	22029



WE WILL BEAT ANY PRICE BY 5%!

Project Name
Gadsden County SD - Stewart St...



Customer / Bill To
Gadsden County School District Tammy McGriff 35 Martin Luther King Blvd Quincy, FL 32351

Ship To
Stewart Street Elementary Johnny Riley 749 South Stewart Street Quincy, FL 32351

Item	Description	Qty	Cost	Total:
	1.) Install 1x Barrington Ridge Playground System 2.) Install 1x Camp Walden Playground System 3.) Install 1x 2 Bay Arch Post Swing Set 4.) Install 39 tons of aggregate rock subbase 5.) Install 989 square feet of poured in place rubber surfacing with a 2" SBR thickness (6' fall height compliance) with a 50% color tpv and 50% black tpv .5" granule mix (2.5" total rubber thickness) over an aggregate rock subbase 6.) Install 1,152 square feet of poured in place rubber surfacing with a 3" SBR thickness (8' fall height compliance) with a 50% color tpv and 50% black tpv .5" granule mix (3.5" total rubber thickness) over an aggregate rock subbase 7.) Install 1x 45'x28'x15' Standard Hip Shade (on base plates) **NOTES** -Area is 36'x32' (swing set) -Area is 43'x23' (play system) -Total square footage is 2,141 **KINDERGARTEN/PRE-K PLAYGROUND SCOPE OF WORK** 1.) Install 1x Ketchum Playground System			

AGREED AND ACCEPTED:
If the above total price, scope of work, specifications, terms and conditions are acceptable, sign below indicating your acceptance and authorization for Pro Playgrounds to proceed with the work and/or sales transaction described in this quotation. Upon signature and payment in accordance with this quote, Pro Playgrounds will proceed with the work and/or sales transaction.

_____/_____/_____
Signature Name / Title Date

Subtotal:
Sales Tax: (7.5%)
Total:

Terms and Conditions - Price valid for 30 days and subject to change. 1. If installation is not included with your purchase, client will be responsible for coordinating, receiving and unloading of all goods, delivery drivers will not help unload goods. 2. Client will be responsible to inspect goods for defect, damage or missing parts, any deficiency or missing parts must be noted on delivery slip. 3. Client will be responsible for costs due to cancelled or missed delivery appointments. 4. Client has reviewed all items, colors and descriptions on this quote for accuracy and correctness. 5. If quote includes installation of goods, the installation is subject to the terms and conditions of Pro Playgrounds "Standard Installation Agreement" a copy of which may be obtained from your Sales Representative.

Project Name
Gadsden County SD - Stewart St...



Date	Estimate #
9/14/2023	22029

Customer / Bill To
Gadsden County School District
Tammy McGriff
35 Martin Luther King Blvd
Quincy, FL 32351

Ship To
Stewart Street Elementary
Johnny Riley
749 South Stewart Street
Quincy, FL 32351



WE WILL BEAT ANY PRICE BY 5%!

Item	Description	Qty	Cost	Total:
	2.) Install 1x T Swing 3.) Install 18 tons of aggregate rock subbase 4.) Install 572 square feet of poured in place rubber surfacing with a 1.5" SBR thickness (4' fall height compliance) with a 50% black tpv and 50% color tpv .5" granule mix (2" total rubber thickness) over an aggregate rock subbase 5.) Install 440 square feet of poured in place rubber surfacing with a 3" SBR thickness (8' fall height compliance) with a 50% black tpv and 50% color tpv .5" granule mix (3.5" total rubber thickness) over an aggregate rock subbase. 6.) Install 1x 30'x24'x10' Hip Shade with Glide (embedded mount) **NOTES** -Area is 26'x22' (play system) -Area is 20'x22' (T swing) -Total square footage is 1,012 **BIG KIDS PLAYGROUND EQUIPMENT**			
23-PMF035	Barrington Ridge	1	36,839.00	36,839.00
QS-23-PSW006...	2 Bay - Frame w/ Hangers & 2 Bay Belt Seat Package	1	2,399.00	2,399.00
QS-23-PKP025P	Camp Walden - Primary	1	5,913.00	5,913.00

AGREED AND ACCEPTED:
If the above total price, scope of work, specifications, terms and conditions are acceptable, sign below indicating your acceptance and authorization for Pro Playgrounds to proceed with the work and/or sales transaction described in this quotation. Upon signature and payment in accordance with this quote, Pro Playgrounds will proceed with the work and/or sales transaction.

Signature Name / Title Date

Subtotal:
Sales Tax: (7.5%)
Total:

Terms and Conditions - Price valid for 30 days and subject to change. 1. If installation is not included with your purchase, client will be responsible for coordinating, receiving and unloading of all goods, delivery drivers will not help unload goods. 2. Client will be responsible to inspect goods for defect, damage or missing parts, any deficiency or missing parts must be noted on delivery slip. 3. Client will be responsible for costs due to cancelled or missed delivery appointments. 4. Client has reviewed all items, colors and descriptions on this quote for accuracy and correctness. 5. If quote includes installation of goods, the installation is subject to the terms and conditions of Pro Playgrounds "Standard Installation Agreement" a copy of which may be obtained from your Sales Representative.



Pro Playgrounds
8490 Cabin Hill Road
Tallahassee, FL 32311

Quote

Date	Estimate #
9/14/2023	22029

Project Name
Gadsden County SD - Stewart St...



Customer / Bill To
Gadsden County School District Tammy McGriff 35 Martin Luther King Blvd Quincy, FL 32351

Ship To
Stewart Street Elementary Johnny Riley 749 South Stewart Street Quincy, FL 32351

WE WILL BEAT ANY PRICE BY 5%!

Item	Description	Qty	Cost	Total:
	KINDERGARTEN/PRE-K PLAYGROUND EQUIPMENT			
23-PKP260	Ketchum	1	9,153.00	9,153.00
QS-23-PSW019...	2 Cantilevers - Frame w/ Hangers, 1 Bay Bucket Package	1	1,299.00	1,299.00
Shipping	Combined Shipping and Freight Charges	1	3,840.00	3,840.00
	SHADE/SHELTER			
CSSD	Custom Shade Design	1	21,199.00	21,199.00
22-RD243010IG	30'x24'x10' Height -INGROUND - WITH GLIDE - RECTANGLE	1	9,799.00	9,799.00
Shipping	Combined Shipping and Freight Charges	1	1,188.55	1,188.55
	SITE AMMENITIES			
22-B6WBULP	6' UltraLeisureStandard Bench with Back, Portable	4	599.00	2,396.00
22-T6UL	6' UltraLeisureRectangular Portable Table	1	1,099.00	1,099.00
22-T6ULHDCP	6' UltraLeisureAccessible Rectangular Portable Table*	1	1,199.00	1,199.00
Shipping	Combined Shipping and Freight Charges	1	1,366.60	1,366.60
	SURFACING MATERIALS			
TPV-BT	Premium 1350 Black Granules T	67	37.8809	2,538.02
TPV-CT	Color TPV Granules T	67	106.11448	7,109.67
SBRT	SBR Buffings T	322	30.95239	9,966.67

AGREED AND ACCEPTED: If the above total price, scope of work, specifications, terms and conditions are acceptable, sign below indicating your acceptance and authorization for Pro Playgrounds to proceed with the work and/or sales transaction described in this quotation. Upon signature and payment in accordance with this quote, Pro Playgrounds will proceed with the work and/or sales transaction.	Subtotal:
	Sales Tax: (7.5%)
	Total:
Signature _____ / / Name / Title _____ Date _____	

Terms and Conditions - Price valid for 30 days and subject to change. 1. If installation is not included with your purchase, client will be responsible for coordinating, receiving and unloading of all goods, delivery drivers will not help unload goods. 2. Client will be responsible to inspect goods for defect, damage or missing parts, any deficiency or missing parts must be noted on delivery slip. 3. Client will be responsible for costs due to cancelled or missed delivery appointments. 4. Client has reviewed all items, colors and descriptions on this quote for accuracy and correctness. 5. If quote includes installation of goods, the installation is subject to the terms and conditions of Pro Playgrounds "Standard Installation Agreement" a copy of which may be obtained from your Sales Representative.



Pro Playgrounds
8490 Cabin Hill Road
Tallahassee, FL 32311

Quote

Date	Estimate #
9/14/2023	22029

Project Name
Gadsden County SD - Stewart St...



Customer / Bill To
Gadsden County School District Tammy McGriff 35 Martin Luther King Blvd Quincy, FL 32351

Ship To
Stewart Street Elementary Johnny Riley 749 South Stewart Street Quincy, FL 32351

WE WILL BEAT ANY PRICE BY 5%!

Item	Description	Qty	Cost	Total:
ARODT	PremArc Aromatic T Binder Drum	8	1,741.57125	13,932.57
AROPT	PremArc Aromatic Binder-T Pail	2	188.50	377.00
Shipping	Combined Shipping and Freight Charges	1	3,000.00	3,000.00
RAW MATERIALS				
AGG	Locally sourced crushed aggregate base materials (ABC Crush and Run Typical)	57	45.00	2,565.00
FBLOCK	Footer Blocks	86	3.75	322.50
CC80	Concrete for Anchoring - Delivered Cost	140	8.40	1,176.00
RBAR5	No. 5 Rebar	950	1.25	1,187.50
RMC	Ready Mix Concrete 2500 PSI MIN	21	200.00	4,200.00
RENTALS, LABOR, AND INSTALLATION				
22-Rentals	Rentals Necessary for Installation	1	15,321.58	15,321.58
LBR	Labor Demolition and Removal	1	22,252.50	22,252.50
LBR	Equipment Installation Per Contract	1	31,953.25	31,953.25
LBR	Surfacing Installation Per Contract	1	11,873.38	11,873.38
DSC	Discount - Per Contract Equipment		-9,129.50	-9,129.50
DSC	Discount - Per Contract Surfacing		-3,392.39	-3,392.39
DSC	Discount - Additional		-8,944.90	-8,944.90

AGREED AND ACCEPTED:
If the above total price, scope of work, specifications, terms and conditions are acceptable, sign below indicating your acceptance and authorization for Pro Playgrounds to proceed with the work and/or sales transaction described in this quotation. Upon signature and payment in accordance with this quote, Pro Playgrounds will proceed with the work and/or sales transaction.

_____/_____/_____
Signature Name / Title Date

Subtotal:	\$203,999.00
Sales Tax: (7.5%)	\$0.00
Total:	\$203,999.00

Terms and Conditions - Price valid for 30 days and subject to change. 1. If installation is not included with your purchase, client will be responsible for coordinating, receiving and unloading of all goods, delivery drivers will not help unload goods. 2. Client will be responsible to inspect goods for defect, damage or missing parts, any deficiency or missing parts must be noted on delivery slip. 3. Client will be responsible for costs due to cancelled or missed delivery appointments. 4. Client has reviewed all items, colors and descriptions on this quote for accuracy and correctness. 5. If quote includes installation of goods, the installation is subject to the terms and conditions of Pro Playgrounds "Standard Installation Agreement" a copy of which may be obtained from your Sales Representative.

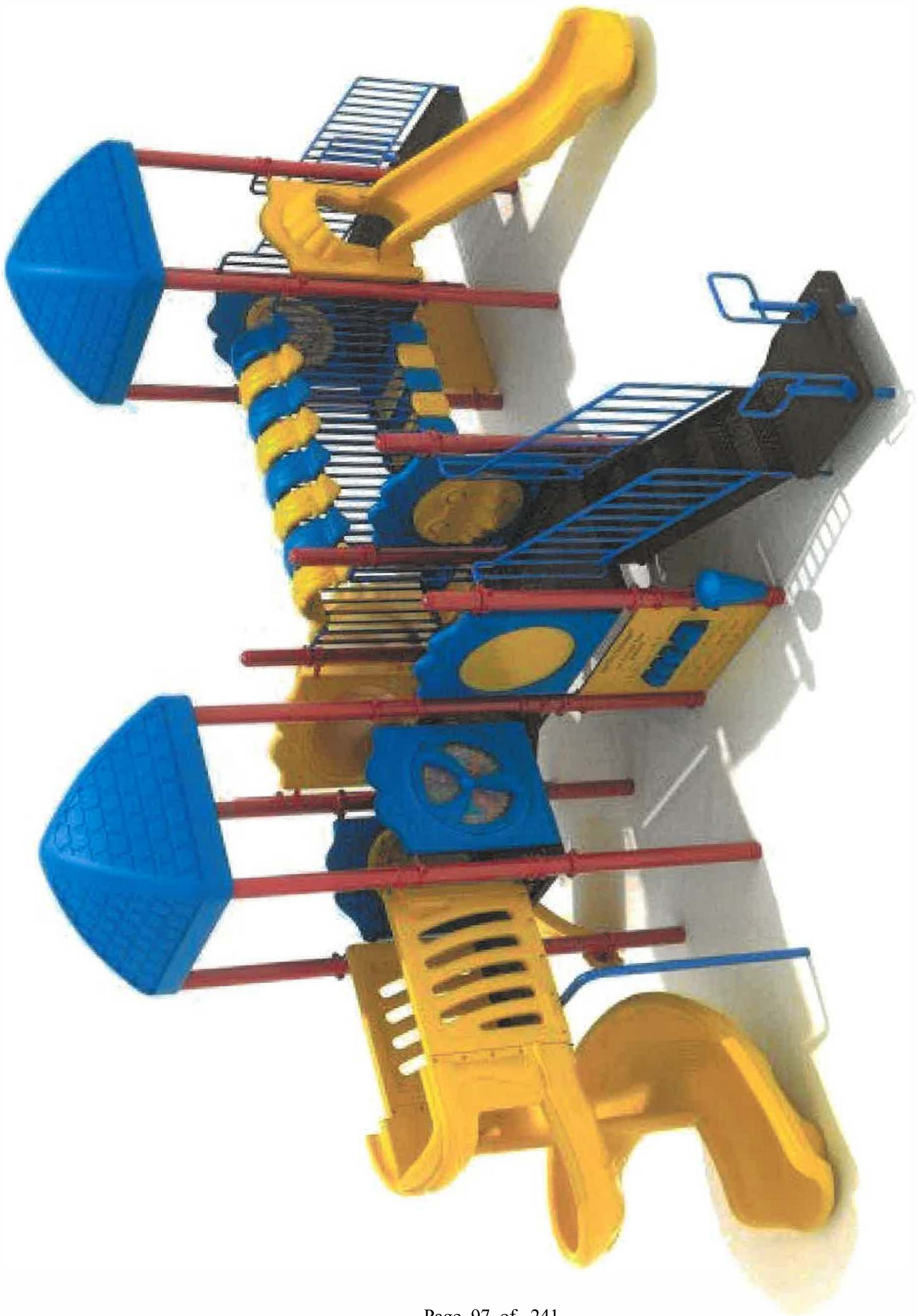

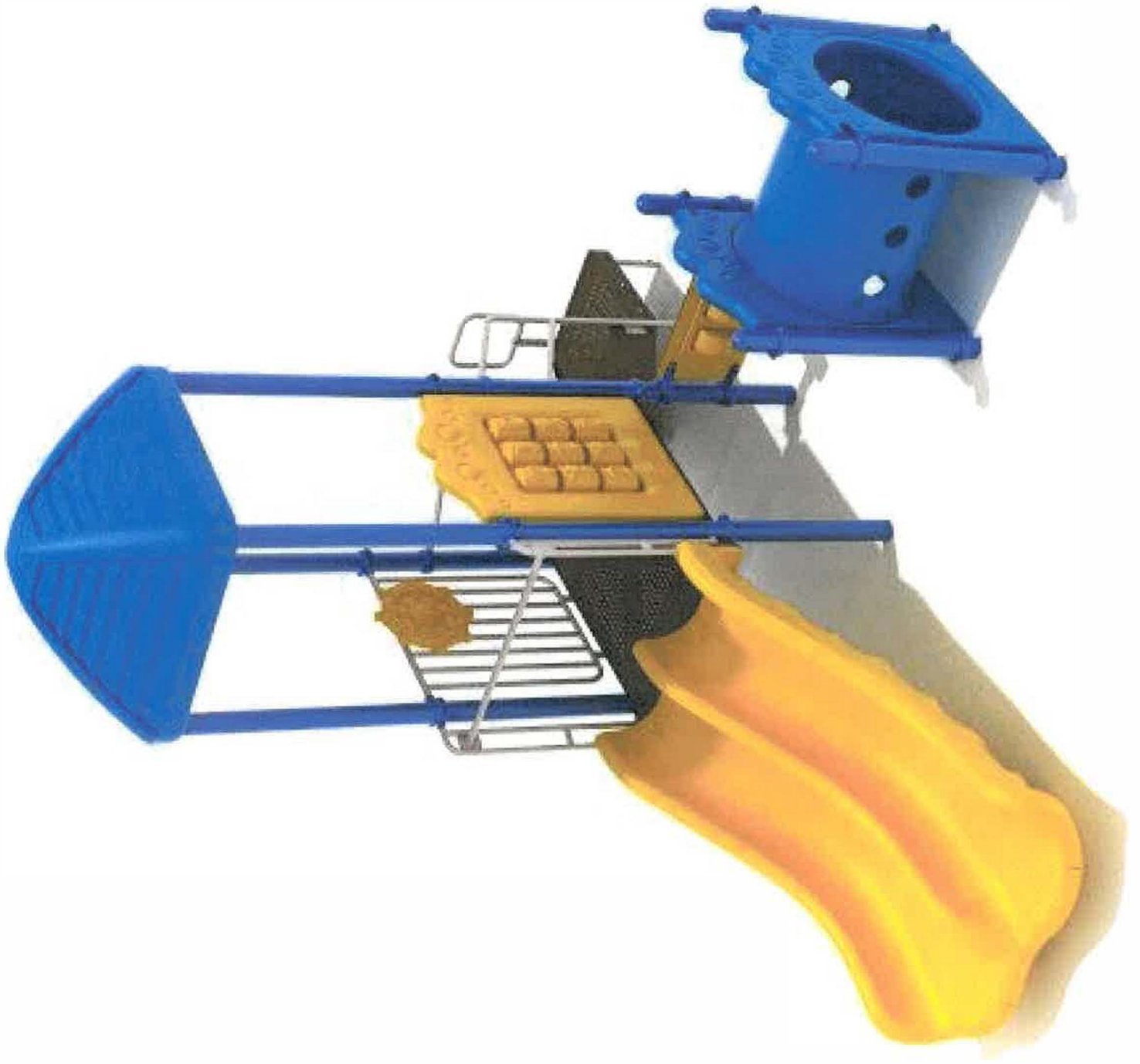

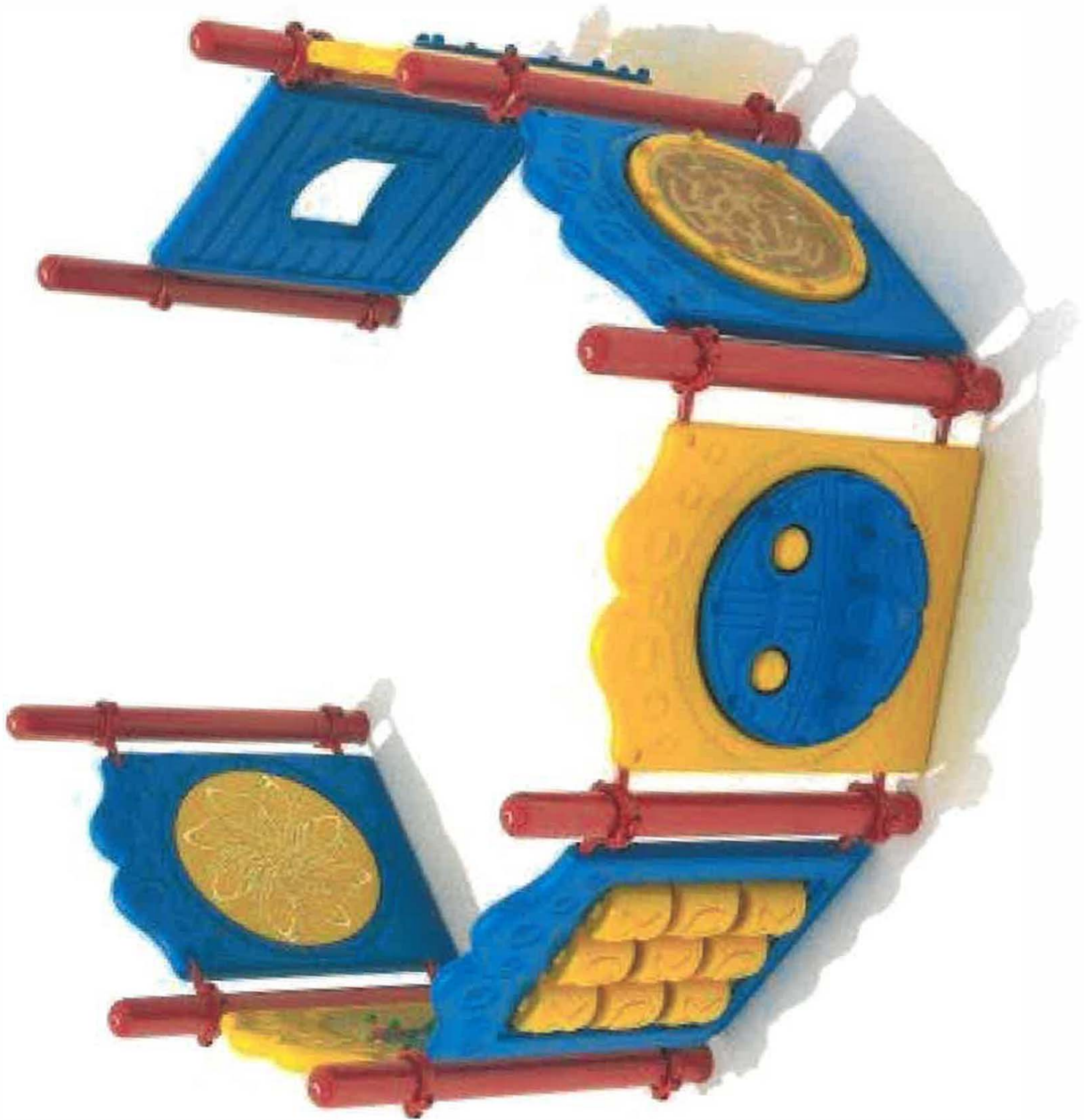









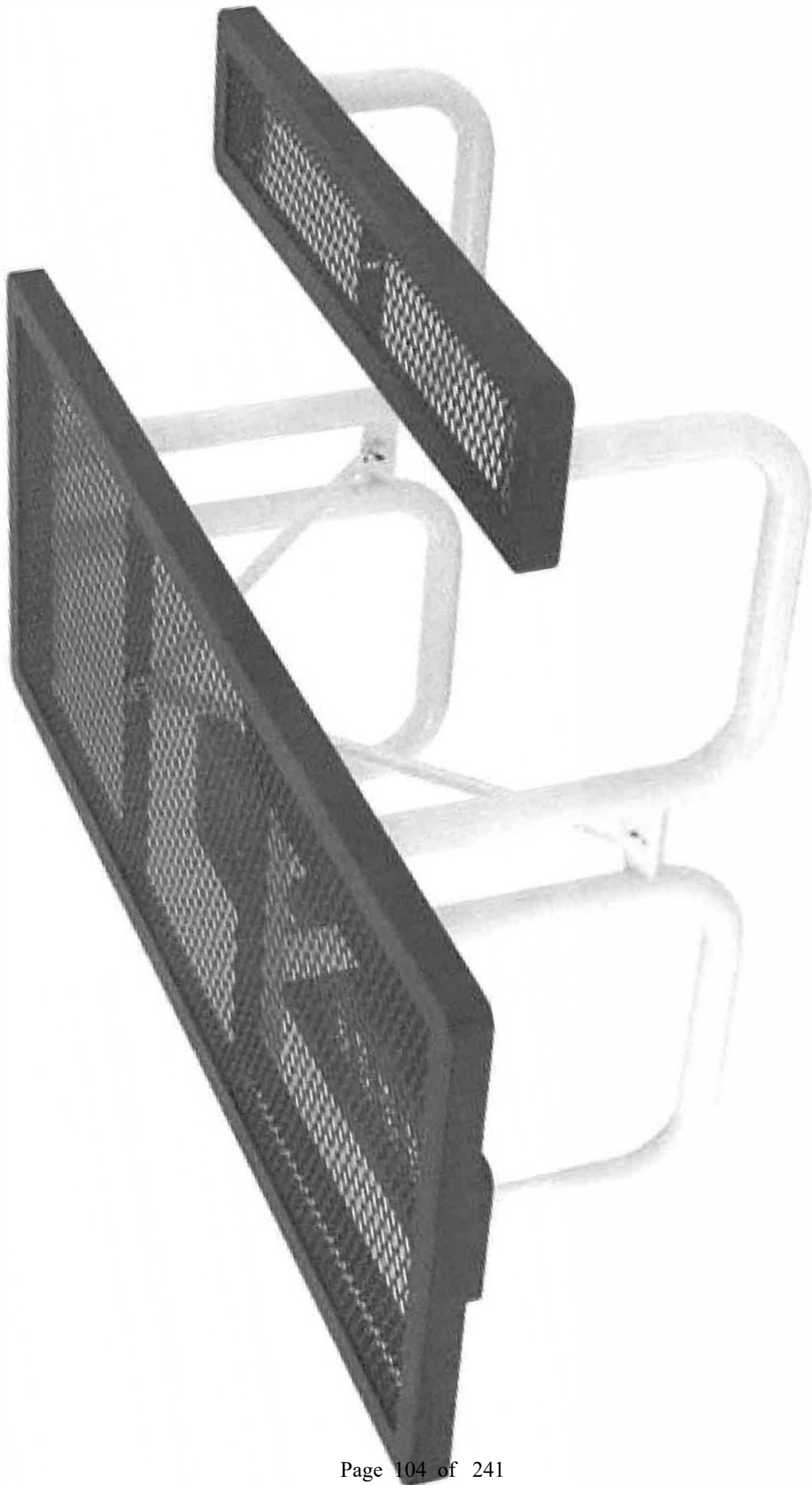

Hip Shade

Length	45'	Width	28'	Entry Height	15'
Peak Height	20.65'	Elbow	Standard	Column Mount	Base Plate
Column Size	10"x10"x1/4"	Rafter Size	Ø5.0" 7-Ga	Ridge Size	Ø5.0" 7-Ga
Column Length	15.5'	Rafter Length	19.91'	Ridge Length	19.06'
Dome Qty.	1	Column Qty.	4		

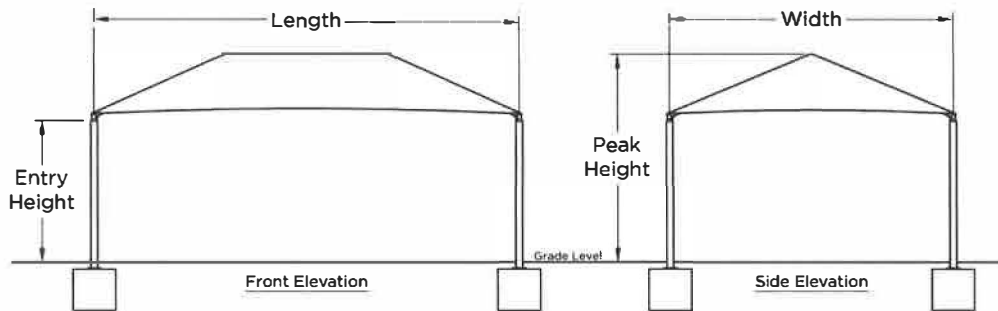
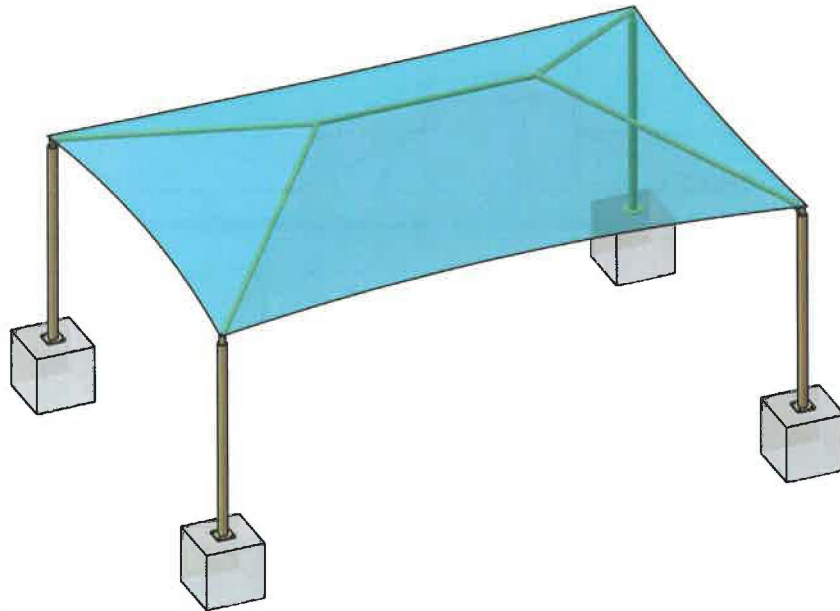

Square Footing		
Column	Length & Width	Depth
Single Cap	5.63	3
Double Cap	N/A	3

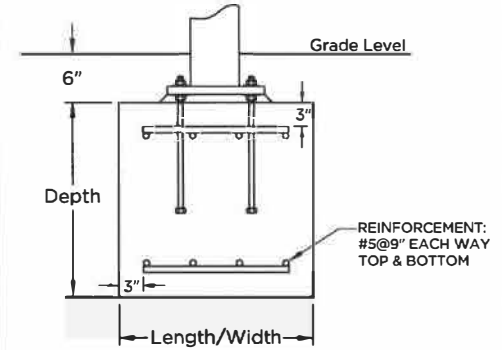

Auger Footing		
Diameter	Single Cap Depth	Double Cap Depth
1'-6"		
2'-0"	Out of range	N/A
2'-6"	Out of range	N/A
3'-0"	10.78	N/A

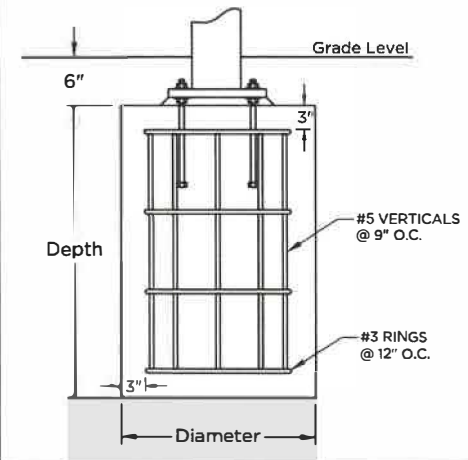

Superior Shade

QUOTE

SHADE SIZE

45 X 28

SHADE STYLE

Hip Shade

These drawings are for reference only and should not be used as construction details. They show the general character and rough dimensions of the structural features. Exact spans, fasteners, materials, and foundations can be determined by a licensed professional engineer upon request. Estimated footing size above is based on 1,500 PSF soil bearing pressure.

Hip Shade

Length	30'	Width	24'	Entry Height	10'
Peak Height	14.85'	Elbow	Glide	Column Mount	Embedded
Column Size	Ø5.5" Sch-40	Rafter Size	Ø3.5" 11-Ga	Ridge Size	Ø3.5" 11-Ga
Column Length	13'	Rafter Length	17.06'	Ridge Length	7.76'
Dome Qty.	1	Column Qty.	4		

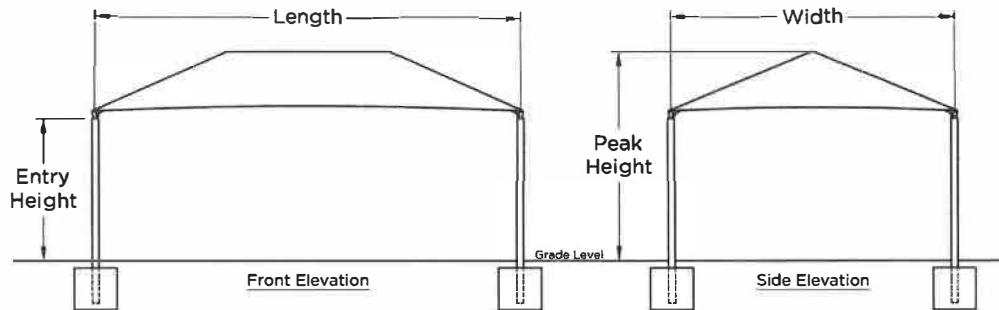
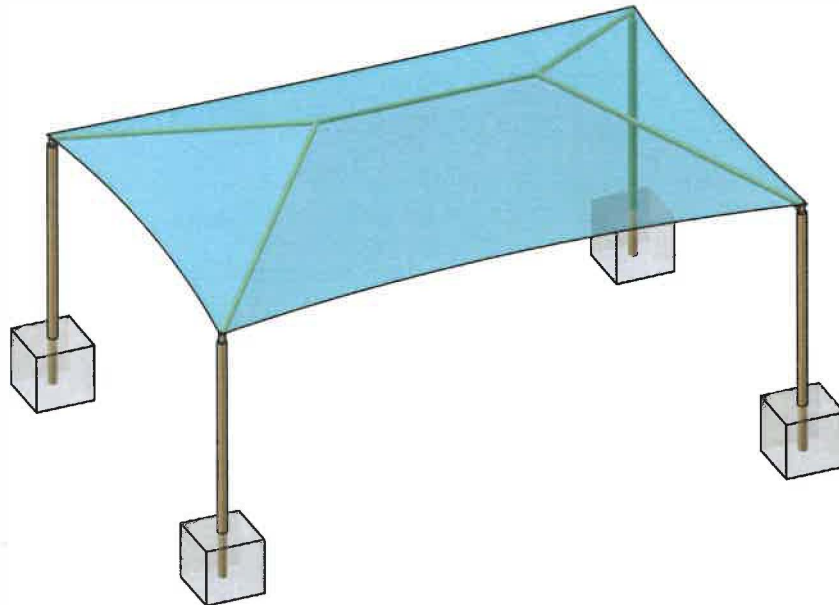

Square Footing		
Column	Length & Width	Depth
Single Cap	3.52	3
Double Cap	N/A	3

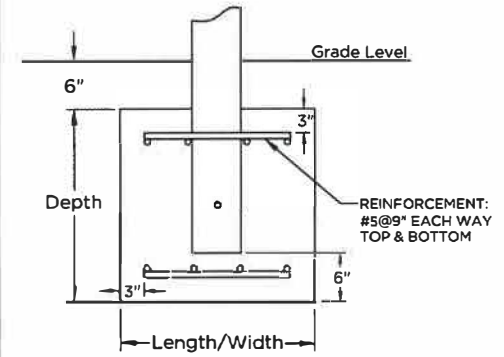

Auger Footing		
Diameter	Single Cap Depth	Double Cap Depth
1'-6"		
2'-0"	Out of range	N/A
2'-6"	Out of range	N/A
3'-0"	4.2	N/A

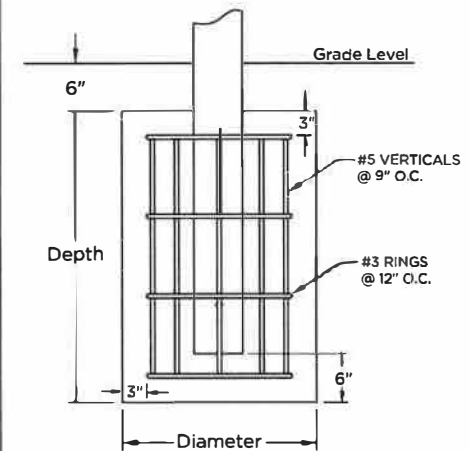

SuperiorShade

QUOTE

SHADE SIZE

30 X 24

SHADE STYLE

Hip Shade

These drawings are for reference only and should not be used as construction details. They show the general character and rough dimensions of the structural features. Exact spans, fasteners, materials, and foundations can be determined by a licensed professional engineer upon request. Estimated footing size above is based on 1,500 PSF soil bearing pressure.

SUMMARY SHEET

RECOMMENDATION TO SUPERINTENDENT FOR SCHOOL BOARD AGENDA

AGENDA ITEM NO. 4b

DATE OF SCHOOL BOARD MEETING: October 10, 2023

TITLE OF AGENDA ITEM: Purchase Order Request for Shaw Integrated Solutions

DIVISION: Facilities

 This is a CONTINUATION of a current project, grant, etc.

PURPOSE AND SUMMARY OF ITEM: This request is for School Board approval of two purchase orders to be issued to Shaw Integrated Solutions. This would be for the purchase and installation of luxury vinyl tile (LVT) to replace the carpet in select rooms at Gadsden County HS and Building #7 at 655 South Stewart Street. Additionally, this includes the replacement of the existing LVT with new LVT at these same select rooms and locations. These materials and services are available from Shaw Integrated Solutions through a solicitation award from Sourcewell (Contract #080819-SII). Attached are copies of the two quotes and the agreement between Sourcewell and Shaw Industries, Inc.

FUND SOURCE: ESSER 2 lump sum

AMOUNT: Gadsden County High School - \$44,072.00
Building #7 at 655 South Stewart Street - \$25,941.16

PREPARED BY: Brenton Hudson *BEH*

POSITION: Director of Facilities

INTERNAL INSTRUCTIONS TO BE COMPLETED BY PREPARER

1 Number of ORIGINAL SIGNATURES NEEDED by preparer.

SUPERINTENDENT'S SIGNATURE: page(s) numbered 1

CHAIRMAN'S SIGNATURE: page(s) numbered NA

REVIEWED BY: 



Proposal Submitted To School Board of Gadsden County		Attention Accounts Payable		Phone (850) 627-9651		Fax () -		Date 08/29/23	
Proposal Name Gadsden High School - Rms 824, 826, 828, 829, 810,				Job Name STFLS- Gadsden High School - Rms 824, 82				Job # 168978	
Street School Board of Gadsden County 35 Martin L King, Jr. Blvd				Job Street 35 Martin Luther King Jr Blvd				Proposal ID 190888	
City, State and Zip Quincy, FL 32351		Architect Sourcewell FL	Date of Plans	Add #	Job City, State and Zip Quincy, FL 32351--441		Customer Job # None	Customer PO None	

We hereby submit specifications and estimates for:

<u>Item Description</u>	<u>Color</u>	<u>Qty</u>	<u>UOM</u>	<u>Unit Price</u>	<u>Extended Price</u>
Terrain II 20 mil LVT 6" x 48"	TBS/To Be Selected	7,200.00	SF	\$2.00	\$14,400.00
LokWorx Resilient Adhesive 4 Gallon		7.00	Each	\$155.00	\$1,085.00
Carpet Removal		800.00	SY	\$3.03	\$2,424.00
Carpet Disposal		800.00	SY	\$1.20	\$960.00
4" Vinyl Base Installation- excludes materials		900.00	LF	\$1.33	\$1,197.00
Transitions Installation- excludes materials		60.00	LF	\$1.05	\$63.00
Furniture Removal and Replacement		29.00	SY	\$55.00	\$1,595.00
Skimcoat - Labor & Material (LVT requires two skimcoats)		7,200.00	SF	\$0.74	\$5,328.00
LVT Installation- no pattern; excludes materials		7,200.00	SF	\$1.99	\$14,328.00
OM - 4" Vinyl Base		900.00	LF	\$1.65	\$1,485.00
OM - Transition Material		60.00	SF	\$2.30	\$138.00
Estimated Freight - Pricing Good for 30 Days		1.00	Each	\$1,069.00	\$1,069.00
Base Bid Total:					\$44,072.00

Proposal Inclusions and Exclusions:

1. Sourcewell Contract# 080819-SII
2. 30161700-20-ACS
3. Local Contact: Kelly Bonds
4. Material title and risk of loss passes to the purchaser at the time of material delivery to owner provided address
5. Proposal does not include removal of any materials containing asbestos.
6. All pricing is based on work being completed during normal working hours.
7. Extensive floor prep is not included in the price but may be necessary due to unforeseen conditions of the sub-floor. This work may include, but is not limited to, leveling or grinding, encapsulation or sealing, or extensive scraping of the sub-floor. Should extensive floor prep be required, you will receive a change order for the necessary work.
8. Exclusions: attic stock, major floor prep, furniture moving unless specified in proposal, disconnecting and moving of computers and electronic equipment, vacuuming and protection of finished products, and any plumbing work (removal of commodes, etc)..
9. Price is based on a consecutive installation period without delays and is based on the customer allowing installation crews access to work a minimum of 8 consecutive hours a day until completion. Delays other than "acts of God" will result in charges for down-time.
10. Please email your Purchase Order to Chad Cloer at chad.cloer@shawinc.com to initiate the order process. A purchase order is required before materials can be shipped.
11. A 2.5% fee will be assessed on the total bid amount at time of payment if utilizing a credit card.
12. Remit to Address: SHAW INTEGRATED SOLUTIONS, PO Box 748552, Atlanta GA 30384-8552

Mail Drop 999 P.O. Box 748552
Atlanta, GA 30384-8552
Proposal ID: 190888



Phone: () -
Fax: () -

We PROPOSE to perform the work complete in accordance with the specifications and as described above for the SUM of:

Signature: Chad Cloer Chad Cloer \$44,072.00

Email: chad.cloer@shawinc.com

Conditions of Proposal:

1. This Proposal may be withdrawn, if not accepted, within 30 days of its issuance. Shaw Industries Group, Inc. will consider reasonable requests to engage in negotiations for revisions to this Proposal, including signing a subcontract that includes the terms of this Proposal. A proposal not accepted within 30 days will be subject to price escalation of materials, labor, freight and fuel costs.
2. This proposal is subject to credit review and approval. Payment terms are net 30 days. A convenience fee of 2.5% will be added if paying via credit card. Past due invoices are subject to service charges of 1.5% per month (18% per annum). In the case of any default, Customer shall pay Shaw Industries Group, Inc.'s reasonable attorney fees and costs, including those on any appeal, even if no suit or action is filed.
3. All work shall be performed in a workmanlike manner according to industry standards. Areas to receive flooring shall be free and clear of debris. Any changes to the work shall be performed only after execution of a written change order.
4. Prior to commencement of Shaw Industries Group, Inc.'s work: (a) Customer shall test all concrete sub floors receiving flooring for vapor emission levels and alkalinity per manufacturers' recommendations utilizing ASTM F2170 and provide written results to Shaw Industries Group, Inc., including a list of any sealers applied to the concrete sub floor; (b) If Customer does not provide such reports at least 10 days prior to commencement of Shaw Industries Group, Inc.'s work, then Customer shall provide Shaw Industries Group, Inc. with access to all concrete sub floors for appropriate testing and Customer shall be responsible for the costs of such testing; and (c) Any concrete sub floors not meeting manufacturers' requirements for installation will require correction or the execution of a separate waiver agreement.
5. All work is contingent upon strikes, accidents or delays beyond Shaw Industries Group, Inc.'s control. Customer shall carry insurance for all hazards, including fire. Shaw Industries Group, Inc.'s workers are fully covered by Worker's Compensation and Liability Insurance.
6. Customer represents and warrants that: (a) the project site contains no hazardous or other dangerous substances, either exposed or concealed; or (b) Customer has given written notice to Shaw Industries Group, Inc. of all such substances and their location(s). To the fullest extent permitted by law, Customer shall indemnify, defend and hold Shaw Industries Group, Inc. harmless from any damage, claim, loss, expense and attorney fees related to Shaw Industries Group, Inc.'s liability, if any, including any federal or state statute related to hazardous or other dangerous substances.
7. Shaw Industries Group, Inc. is fully licensed, bonded, and insured. This proposal does not include participation in any OCIP/CCIP or related programs. Requests for Shaw Industries Group, Inc. to participate in such programs may result in additional costs.

ACCEPTANCE OF PROPOSAL: The above prices, specifications, and conditions are satisfactory and are hereby ACCEPTED. You are authorized to do the work as specified.

Customer: School Board of Gadsden County Sign Page 109 of 241 Date: _____



Proposal Submitted To School Board of Gadsden County		Attention Accounts Payable		Phone (850) 627-9651		Fax () -		Date 09/11/23	
Proposal Name STFLS- ESE Bldg Lobby, Rms, Breakrm LVT				Job Name STFLS- ESE Bldg Lobby, Rms, Breakrm LVT				Job # 169429	
Street School Board of Gadsden County 35 Martin L King, Jr. Blvd				Job Street 35 Martin Luther King Jr Blvd				Proposal ID 191418	
City, State and Zip Quincy, FL 32351		Architect Sourcewell FL	Date of Plans	Add #	Job City, State and Zip Quincy, FL 32351--441		Customer Job # None	Customer PO None	

We hereby submit specifications and estimates for:

<u>Item Description</u>	<u>Color</u>	<u>Qty</u>	<u>UOM</u>	<u>Unit Price</u>	<u>Extended Price</u>
Terrain II 20 mil LVT 6" x 48"	TBS/To Be Selected	3,796.52	SF	\$2.00	\$7,593.04
LokWorx Resilient Adhesive 4 Gallon		4.00	Each	\$155.00	\$620.00
Carpet Demolition (standard)		242.00	SY	\$3.03	\$733.26
Carpet Disposal		242.00	Each	\$1.33	\$321.86
Transition Installation (excludes materials)		48.00	LF	\$1.25	\$60.00
Furniture Removal and Replacement		18.00	SY	\$60.50	\$1,089.00
LVT/VCT Demolition (standard)		1,540.00	SY	\$0.83	\$1,278.20
LVT/VCT Disposal		1,540.00	Each	\$0.55	\$847.00
Skimcoat - Labor & Material (LVT requires two skimcoats)		3,780.00	Each	\$0.74	\$2,797.20
LVT Installation (no pattern; excludes materials)		3,780.00	SF	\$1.99	\$7,522.20
Furnish and Install 4 1/2" Base		800.00	LF	\$3.00	\$2,400.00
OM - Transition Material		48.00	SF	\$2.30	\$110.40
Estimated Freight - Pricing Good for 30 Days		1.00	Each	\$569.00	\$569.00
Base Bid Total:					\$25,941.16

Proposal Inclusions and Exclusions:

1. Sourcewell Contract# 080819-SII
2. 30161700-20-ACS
3. Local Contact: Kelly Bonds
4. Material title and risk of loss passes to the purchaser at the time of material delivery to owner provided address
5. Proposal does not include removal of any materials containing asbestos.
6. All pricing is based on work being completed during normal working hours.
7. Extensive floor prep is not included in the price but may be necessary due to unforeseen conditions of the sub-floor. This work may include, but is not limited to, leveling or grinding, encapsulation or sealing, or extensive scraping of the sub-floor. Should extensive floor prep be required, you will receive a change order for the necessary work.
8. Exclusions: attic stock, major floor prep, furniture moving unless specified in proposal, disconnecting and moving of computers and electronic equipment, vacuuming and protection of finished products, and any plumbing work (removal of commodes, etc)..
9. Price is based on a consecutive installation period without delays and is based on the customer allowing installation crews access to work a minimum of 8 consecutive hours a day until completion. Delays other than "acts of God" will result in charges for down-time.
10. Please email your Purchase Order to Chad Cloer at chad.cloer@shawinc.com to initiate the order process. A purchase order is required before materials can be shipped.
11. A 2.5% fee will be assessed on the total bid amount at time of payment if utilizing a credit card.
12. Remit to Address: SHAW INTEGRATED SOLUTIONS, PO Box 748552, Atlanta GA 30384-8552



Phone: () -
Fax: () -

Mail Drop 999 P.O. Box 748552
Atlanta, GA 30384-8552
Proposal ID: 191418

We PROPOSE to perform the work complete in accordance with the specifications and as described above for the SUM of:

Signature: Chad Cloer

Chad Cloer

\$25,941.16

Email: chad.cloer@shawinc.com

Conditions of Proposal:

1. This Proposal may be withdrawn, if not accepted, within 30 days of its issuance. Shaw Industries Group, Inc. will consider reasonable requests to engage in negotiations for revisions to this Proposal, including signing a subcontract that includes the terms of this Proposal. A proposal not accepted within 30 days will be subject to price escalation of materials, labor, freight and fuel costs.
2. This proposal is subject to credit review and approval. Payment terms are net 30 days. A convenience fee of 2.5% will be added if paying via credit card. Past due invoices are subject to service charges of 1.5% per month (18% per annum). In the case of any default, Customer shall pay Shaw Industries Group, Inc.'s reasonable attorney fees and costs, including those on any appeal, even if no suit or action is filed.
3. All work shall be performed in a workmanlike manner according to industry standards. Areas to receive flooring shall be free and clear of debris. Any changes to the work shall be performed only after execution of a written change order.
4. Prior to commencement of Shaw Industries Group, Inc.'s work: (a) Customer shall test all concrete sub floors receiving flooring for vapor emission levels and alkalinity per manufacturers' recommendations utilizing ASTM F2170 and provide written results to Shaw Industries Group, Inc., including a list of any sealers applied to the concrete sub floor; (b) If Customer does not provide such reports at least 10 days prior to commencement of Shaw Industries Group, Inc.'s work, then Customer shall provide Shaw Industries Group, Inc. with access to all concrete sub floors for appropriate testing and Customer shall be responsible for the costs of such testing; and (c) Any concrete sub floors not meeting manufacturers' requirements for installation will require correction or the execution of a separate waiver agreement.
5. All work is contingent upon strikes, accidents or delays beyond Shaw Industries Group, Inc.'s control. Customer shall carry insurance for all hazards, including fire. Shaw Industries Group, Inc.'s workers are fully covered by Worker's Compensation and Liability Insurance.
6. Customer represents and warrants that: (a) the project site contains no hazardous or other dangerous substances, either exposed or concealed; or (b) Customer has given written notice to Shaw Industries Group, Inc. of all such substances and their location(s). To the fullest extent permitted by law, Customer shall indemnify, defend and hold Shaw Industries Group, Inc. harmless from any damage, claim, loss, expense and attorney fees related to Shaw Industries Group, Inc.'s liability, if any, including any federal or state statute related to hazardous or other dangerous substances.
7. Shaw Industries Group, Inc. is fully licensed, bonded, and insured. This proposal does not include participation in any OCIP/CCIP or related programs. Requests for Shaw Industries Group, Inc. to participate in such programs may result in additional costs.

**ACCEPTANCE OF PROPOSAL: The above prices, specifications, and conditions are satisfactory and are hereby ACCEPTED.
You are authorized to do the work as specified.**

Customer: School Board of Gadsden County _____ **Signed:** 111 of 241 _____ **Date:** _____



CONTRACT EXTENSION

Contract Number: #080819-SII

Sourcewell, 202 12th Street Northeast, P.O. Box 219, Staples, MN 56479 (Sourcewell) and Shaw Industries, Inc., 616 E. Walnut Avenue, Dalton, GA 30721 (Vendor) have entered into Contract #080819-SII for the procurement of Flooring Materials, with Related Supplies and Services. The Contract has an expiration date of October 11, 2023, but the parties may extend the Contract by mutual consent.

Sourcewell and Vendor acknowledge that extending the Contract benefits the Vendor, Sourcewell and Sourcewell's Members. Vendor and Sourcewell agree to extend the Contract listed above for an additional period, with a new Contract expiration date of October 11, 2024. All other terms and conditions of the Contract remain in full force and effect.

Sourcewell

DocuSigned by:
Jeremy Schwartz
By: COFD2A139D06489...
Jeremy Schwartz

Title: Chief Procurement Officer
6/15/2023 | 7:15 AM CDT
Date: _____

Shaw Industries, Inc.

DocuSigned by:
James L. Kirkpatrick
By: D68140FCEE7242B...
James L Kirkpatrick

Title: Treasurer / CFO
6/21/2023 | 3:45 AM PDT
Date: _____



Solicitation Number: 080819 CONTRACT

This Contract is between Sourcewell, 202 12th Street Northeast, P.O. Box 219, Staples, MN 56479 (Sourcewell) and Shaw Industries, Inc., 616 E. Walnut Avenue, Dalton, GA 30721 (Vendor).

Sourcewell is a State of Minnesota local government agency and service cooperative created under the laws of the State of Minnesota (Minnesota Statutes Section 123A.21) that offers cooperative procurement solutions to its members. Participation is open to all levels of governmental entity, higher education, K-12 education, nonprofit, tribal government, and other public entities located in the United States and Canada.

Vendor desires to contract with Sourcewell to provide equipment, products, or services to Sourcewell and its Members (Members).

For clarification and avoidance of doubt, this Contract entirely supersedes and replaces the prior Contract version, signed on October 8, 2019.

1. TERM OF CONTRACT

A. **EFFECTIVE DATE.** This Contract is effective upon the date of the final signature below.

B. **EXPIRATION DATE AND EXTENSION.** This Contract expires October 11, 2023, unless it is cancelled sooner pursuant to Article 24. This Contract may be extended up to one additional one-year period upon request of Sourcewell and with written agreement by Vendor.

C. **SURVIVAL OF TERMS.** Articles 11 through 16 survive the expiration or cancellation of this Contract.

2. EQUIPMENT, PRODUCTS, OR SERVICES

A. **EQUIPMENT, PRODUCTS, OR SERVICES.** Vendor will provide the Equipment, Products, or Services as stated in its Proposal submitted under the Solicitation Number listed above. Vendor's Equipment, Products, or Services Proposal (Proposal) is attached and incorporated into this Contract.

All Equipment and Products provided under this Contract must be new/current model. Vendor may offer close-out or refurbished Equipment or Products if they are clearly indicated in Vendor's product and pricing list. Unless agreed to by the Member in advance, Equipment or Products must be delivered as operational to the Member's site.

This Contract offers an indefinite quantity of sales, and while substantial volume is anticipated, sales and sales volume are not guaranteed.

- B. **LAWS AND REGULATIONS.** All Equipment, Products, or Services must comply fully with applicable federal laws and regulations, and with the laws of the state or province in which the Equipment, Products, or Services are sold.
- C. **WARRANTY.** Vendor warrants that all Equipment, Products, and, subject to the applicable generally-published manufacturer's limited product warranty, Services furnished are free from liens and encumbrances, and are free from defects in design, materials, and workmanship. Vendor's dealers and distributors must agree to assist the Member in reaching a resolution in any dispute over warranty terms with the manufacturer. Any manufacturer's warranty that is effective past the expiration of the Vendor's warranty will be passed on to the Member. EXCEPT AS EXPRESSLY SET FORTH HEREIN AND TO THE MAXIMUM EXTENT PERMITTED BY LAW, VENDOR MAKES NO OTHER WARRANTIES FOR ANY EQUIPMENT, PRODUCTS, SERVICES, OR MATERIALS PROVIDED UNDER THIS AGREEMENT AND HEREBY DISCLAIMS ALL OTHER WARRANTIES, EXPRESS OR IMPLIED, INCLUDING THE WARRANTY OF FITNESS FOR A PARTICULAR PURPOSE OR USE.
- D. **DEALERS AND DISTRIBUTORS.** Upon Contract execution, Vendor will make available to Sourcewell a means to validate or authenticate Vendor's authorized Distributors/Dealers relative to the Equipment, Products, and Services related to this Contract. This list may be updated from time-to-time and is incorporated into this Contract by reference. It is the Vendor's responsibility to ensure Sourcewell receives the most current version of this list.

3. PRICING

All Equipment, Products, or Services under this Contract will be priced as stated in Vendor's Proposal.

Regardless of the payment method chosen by the Member, the total cost associated with any purchase option of the Equipment, Products, or Services must always be disclosed in the pricing quote to the applicable Member at the time of purchase.

When providing pricing quotes to Members, all pricing quoted must reflect a Member's total cost of acquisition. This means that the quoted cost is for delivered Equipment, Products, and Services that are operational for their intended purpose, and includes all costs to the Member's requested delivery location.

A. **SHIPPING AND SHIPPING COSTS.** All delivered Equipment and Products must be properly packaged. Damaged Equipment and Products may be rejected. If the damage is not readily apparent at the time of delivery, Vendor must permit the Equipment and Products to be returned within a reasonable time at no cost to Sourcewell or its Members. Members reserve the right to inspect the Equipment and Products at a reasonable time after delivery where

circumstances or conditions prevent effective inspection of the Equipment and Products at the time of delivery.

Vendor must arrange for and pay for the return shipment on Equipment and Products that arrive in a defective or inoperable condition.

Sourcewell may declare the Vendor in breach of this Contract if the Vendor intentionally delivers substandard or inferior Equipment or Products. In the event of the delivery of nonconforming Equipment and Products, the Member will notify the Vendor as soon as possible and the Vendor will replace nonconforming Equipment and Products with conforming Equipment and Products that are acceptable to the Member.

B. SALES TAX. Each Member is responsible for supplying the Vendor with valid tax-exemption certification(s). When ordering, Members must indicate if it is a tax-exempt entity. Unless exempt, Members shall be responsible for all applicable taxes arising from the provision of Products, Equipment, or Services under this Contract.

C. HOT LIST PRICING. At any time during this Contract, Vendor may offer a specific selection of Equipment, Products, or Services at discounts greater than those listed in the Contract. When Vendor determines it will offer Hot List Pricing, it must be submitted electronically to Sourcewell in a line-item format. Equipment, Products, or Services may be added or removed from the Hot List at any time through a Sourcewell Price and Product Change Form as defined in Article 4 below.

Hot List program and pricing may also be used to discount and liquidate close-out and discontinued Equipment and Products as long as those close-out and discontinued items are clearly identified as such. Current ordering process and administrative fees apply. Hot List Pricing must be published and made available to all Members.

4. PRODUCT AND PRICING CHANGE REQUESTS

Vendor may request Equipment, Product, Service, or price changes, additions, or deletions at any time. All requests must be made in writing by submitting a signed Sourcewell Price and Product Change Request Form to the assigned Sourcewell Contract Administrator. Sourcewell's approval of such requests shall not be unreasonably withheld. Notwithstanding anything herein to the contrary, Sourcewell will approve all Equipment, Product, and/or Service price increases without limitation if attributable to a material change to applicable duties, taxes, tariffs, similar charges, or other government action, and Sourcewell will use commercially reasonable efforts to expedite the effective implementation of such price increase. This form is available from the assigned Sourcewell Contract Administrator. At a minimum, the request must:

- Identify the applicable Sourcewell contract number
- Clearly specify the requested change
- Provide sufficient detail to justify the requested change
- Individually list all Equipment, Products, or Services affected by the requested

change, along with the requested change (e.g., addition, deletion, price change)

- Include a complete restatement of pricing documentation in Microsoft Excel with the effective date of the modified pricing, or product addition or deletion. The new pricing restatement must include all Equipment, Products, and Services offered, even for those items where pricing remains unchanged.

A fully executed Sourcewell Price and Product Request Form will become an amendment to this Contract and be incorporated by reference.

5. MEMBERSHIP, CONTRACT ACCESS, AND MEMBER REQUIREMENTS

A. MEMBERSHIP. Membership in Sourcewell is open to public and nonprofit entities across the United States and Canada; such as municipal, state/province, K-12 and higher education, tribal government, and other public entities.

The benefits of this Contract should be available to all Members that can legally access the Equipment, Products, or Services under this Contract. A Member's authority to access this Contract is determined through its cooperative purchasing, interlocal, or joint powers laws. Any entity accessing benefits of this Contract will be considered a Service Member of Sourcewell during such time of access. Vendor understands that a Member's use of this Contract is at the Member's sole convenience and Members reserve the right to obtain like Equipment, Products, or Services from any other source.

Vendor is responsible for familiarizing its sales and service forces with Sourcewell membership requirements and documentation and, where appropriate, will use commercially reasonable efforts to encourage potential members to join Sourcewell, unless such potential member is already a member of another group purchasing organization or similar organization. Sourcewell reserves the right to add and remove Members to its roster during the term of this Contract.

B. PUBLIC FACILITIES. Vendor's employees may be required to perform work at government-owned facilities, including schools. Vendor's employees and agents must conduct themselves in a professional manner while on the premises, and in accordance with Member policies and procedures, and all applicable laws.

6. MEMBER ORDERING AND PURCHASE ORDERS

A. PURCHASE ORDERS AND PAYMENT. To access the contracted Equipment, Products, or Services under this Contract, Member must clearly indicate to Vendor that it intends to access this Contract; however, order flow and procedure will be developed jointly between Sourcewell and Vendor. Typically a Member will issue a purchase order directly to Vendor. Members may use their own forms for purchase orders, but it should clearly note the applicable Sourcewell contract number. Members and/or their authorized purchasing agent, contractor, or similar designee shall be solely responsible for noting the applicable Sourcewell contract number on all purchase orders. Members will be solely responsible for payment and Sourcewell will have no liability for

any unpaid invoice of any Member.

- B. ADDITIONAL TERMS AND CONDITIONS.** Additional terms and conditions to a purchase order may be negotiated between a Member and Vendor, such as job or industry-specific requirements, legal requirements (such as affirmative action or immigration status requirements), or specific local policy requirements. Any negotiated additional terms and conditions must never be less favorable to the Member than what is contained in Vendor's Proposal.
- C. PERFORMANCE BOND.** If reasonably requested by a Member, Vendor may provide a performance bond that meets the requirements set forth in the Member's purchase order.
- D. SPECIALIZED SERVICE REQUIREMENTS.** In the event that the Member requires service or specialized performance requirements (such as e-commerce specifications, specialized delivery requirements, or other specifications and requirements) not addressed in this Contract, the Member and the Vendor may enter into a separate, standalone agreement, apart from this Contract. Sourcewell, including its agents and employees, will not be made a party to a claim for breach of such agreement.
- E. TERMINATION OF PURCHASE ORDERS.** Members may terminate a purchase order, in whole or in part, immediately upon notice to Vendor in the event of any of the following events:
1. The Member fails to receive funding or appropriation from its governing body at levels sufficient to pay for the goods to be purchased;
 2. Federal or state laws or regulations prohibit the purchase or change the Member's requirements; or
 3. Vendor commits any material breach of this Contract or the additional terms agreed to between the Vendor and a Member.
- F. GOVERNING LAW AND VENUE.** The governing law and venue for any action related to a Member's purchase order will be determined by the Member making the purchase.

7. CUSTOMER SERVICE

- A. PRIMARY ACCOUNT REPRESENTATIVE.** Vendor will assign an Account Representative to Sourcewell for this Contract and must provide prompt notice to Sourcewell if that person is changed. The Account Representative will be responsible for:
- Maintenance and management of this Contract;
 - Timely response to all Sourcewell and Member inquiries; and
 - Business reviews to Sourcewell and Members, if applicable.
- B. BUSINESS REVIEWS.** Vendor must perform a minimum of one business review with Sourcewell per contract year. The business review will cover sales to members, pricing and

contract terms, administrative fees, supply issues, customer issues, and any other necessary information.

8. REPORT ON CONTRACT SALES ACTIVITY AND ADMINISTRATIVE FEE PAYMENT

- A. **CONTRACT SALES ACTIVITY REPORT.** Each calendar quarter, Vendor must provide a contract sales activity report (Report) to the Sourcewell Contract Administrator assigned to this Contract. A Report must be provided regardless of the number or amount of sales during that quarter (i.e., if there are no sales, Vendor must submit a report indicating no sales were made). Except to the extent applicable law deems the Report and its underlying information public or requires its disclosure, the foregoing will be limited by Vendor's applicable confidentiality obligations, including without limitation any contractual obligations to Members.

The Report must contain the following fields:

- Customer Name (e.g., City of Staples Highway Department);
- Customer Physical Street Address;
- Customer City;
- Customer State;
- Customer Zip Code;
- Customer Contact Name;
- Customer Contact Email Address;
- Customer Contact Telephone Number;
- Sourcewell Assigned Entity/Member Number;
- Item Purchased Description;
- Item Purchased Price;
- Sourcewell Administrative Fee Applied; and
- Date Purchase was invoiced/sale was recognized as revenue by Vendor.

- B. **ADMINISTRATIVE FEE.** In consideration for the support and services provided by Sourcewell, the Vendor will pay an administrative fee to Sourcewell on all Equipment, Products, and Services provided to Members under this Contract. The Vendor will submit a check payable to Sourcewell for the percentage of administrative fee stated in the Proposal multiplied by the total net sales of all Equipment, Products, and Services purchased by Members under this Contract during each calendar quarter, less any applicable taxes, freight, fees, and discounts and less amounts attributable to any Services, freight, delivery installation, unpaid invoices, returned Products or materials, or credits issued. Orders under this Contract will only be eligible for the administrative fee if the Member notes the applicable Sourcewell contract number on the purchase order when submitting such purchase order. Payments should note the Sourcewell-assigned contract number in the memo and must be mailed to the address above "Attn: Accounts Receivable." Payments must be received no later than forty-five (45) calendar days after the end of each calendar quarter.

Vendor agrees to cooperate with Sourcewell in auditing transactions under this Contract to

ensure that the administrative fee is paid on all items purchased under this Contract.

In the event the Vendor is delinquent in any undisputed administrative fees, Sourcewell reserves the right to cancel this Contract and reject any proposal submitted by the Vendor in any subsequent solicitation. In the event this Contract is cancelled by either party prior to the Contract's expiration date, the administrative fee payment will be due no more than thirty (30) days from the cancellation date.

Sourcewell is solely responsible for notifying any Member or other entity participating hereunder of its Administrative Fee and for complying with all laws and regulations related or applicable to such Administrative Fee.

9. AUTHORIZED REPRESENTATIVE

Sourcewell's Authorized Representative is its Chief Procurement Officer.

Vendor's Authorized Representative is the person named in the Vendor's Proposal. If Vendor's Authorized Representative changes at any time during this Contract, Vendor must promptly notify Sourcewell in writing.

10. ASSIGNMENT, AMENDMENTS, WAIVER, AND CONTRACT COMPLETE

- A. **ASSIGNMENT.** Neither the Vendor nor Sourcewell may assign or transfer any rights or obligations under this Contract without the prior consent of the parties and a fully executed assignment agreement. Such consent will not be unreasonably withheld.
- B. **AMENDMENTS.** Any amendment to this Contract must be in writing and will not be effective until it has been fully executed by the parties.
- C. **WAIVER.** If either party fails to enforce any provision of this Contract, that failure does not waive the provision or the right to enforce it.
- D. **CONTRACT COMPLETE.** This Contract contains all negotiations and agreements between Sourcewell and Vendor. No other understanding regarding this Contract, whether written or oral, may be used to bind either party.
- E. **RELATIONSHIP OF THE PARTIES.** The relationship of the parties is one of independent contractors, each free to exercise judgment and discretion with regard to the conduct of their respective businesses. This Contract does not create a partnership, joint venture, master-servant, principal-agent, or any other relationship.

11. LIABILITY

Vendor must indemnify, save, and hold Sourcewell and its Members, including their agents and employees, harmless from any claims or causes of action, including attorneys' fees brought against Sourcewell or its Member by a third party to the extent, arising out of the performance of this Contract by the Vendor or its agents or employees; this indemnification includes injury or death to person(s) or property alleged to have been caused by some defect in the Equipment, Products, or Services under this Contract to the extent the Equipment, Product, or Service has been used according to its specifications.

12. AUDITS

- A. Sourcewell reserves the right to review the books, records, documents, and accounting procedures and practices of the Vendor pursuant to this Contract solely to the extent necessary to verify Vendor's compliance with its obligations hereunder for a minimum of six (6) years from the end of this Contract. This clause extends to Members as it relates to business conducted by that Member under this Contract.

13. GOVERNMENT DATA PRACTICES

Vendor and Sourcewell must comply with the Minnesota Government Data Practices Act, Minnesota Statutes Chapter 13, as it applies to all data provided by or provided to Sourcewell under this Contract and as it applies to all data created, collected, received, stored, used, maintained, or disseminated by the Vendor under this Contract.

If the Vendor receives a request to release the data referred to in this article, the Vendor must immediately notify Sourcewell and Sourcewell will assist with how the Vendor should respond to the request.

14. INTELLECTUAL PROPERTY

As applicable, Vendor agrees to indemnify and hold harmless Sourcewell and its Members against any and all suits, claims, judgments, and costs instituted or recovered against Sourcewell or Members by any person on account of the authorized use of any Equipment or Products by Sourcewell or its Members in accordance with their applicable specifications supplied by Vendor under this Contract in violation of applicable patent or copyright laws.

15. PUBLICITY, MARKETING, AND ENDORSEMENT

- A. **PUBLICITY.** Any publicity regarding the subject matter of this Contract must not be released without prior written approval from the Authorized Representatives. Publicity includes notices, informational pamphlets, press releases, research, reports, signs, and similar public notices prepared by or for the Vendor individually or jointly with others, or any subcontractors, with respect to the program, publications, or services provided resulting from this Contract.

B. **MARKETING.** Any direct advertising, marketing, or offers with Members must be approved by Sourcewell. Materials should be sent to the Sourcewell Contract Administrator assigned to this Contract.

C. **ENDORSEMENT.** The Vendor must not claim that Sourcewell endorses its Equipment, Products, or Services.

16. GOVERNING LAW, JURISDICTION, AND VENUE

Minnesota law governs this Contract. Venue for all legal proceedings out of this Contract, or its breach, must be in the appropriate state court in Todd County or federal court in Fergus Falls, Minnesota.

17. FORCE MAJEURE

Neither party to this Contract will be held responsible for delay or default caused by acts of God or other conditions that are beyond that party's reasonable control. A party defaulting under this provision must provide the other party prompt written notice of the default.

18. SEVERABILITY

If any provision of this Contract is found to be illegal, unenforceable, or void then both Sourcewell and Vendor will be relieved of all obligations arising under such provisions. If the remainder of this Contract is capable of performance, it will not be affected by such declaration or finding and must be fully performed.

19. PERFORMANCE, DEFAULT, AND REMEDIES

A. **PERFORMANCE.** During the term of this Contract, the parties will monitor performance and address unresolved contract issues as follows:

1. **Notification.** The parties must promptly notify each other of any known dispute and work in good faith to resolve such dispute within a reasonable period of time. If necessary, Sourcewell and the Vendor will jointly develop a short briefing document that describes the issue(s), relevant impact, and positions of both parties.
2. **Escalation.** If parties are unable to resolve the issue in a timely manner, as specified above, either Sourcewell or Vendor may escalate the resolution of the issue to a higher level of management. The Vendor will have not less than sixty (60) calendar days, unless otherwise approved in writing, to cure an outstanding issue or, in the event such issue cannot be cured within sixty (60) calendar days, to take material steps to cure such issue, provided that Vendor must continue to diligently pursue such cure until complete.
3. **Performance while Dispute is Pending.** Notwithstanding the existence of a dispute, the Vendor must continue without delay to carry out all of its responsibilities under the Contract that are not affected by the dispute. If the Vendor fails to continue

without delay to perform its responsibilities under the Contract, in the accomplishment of all undisputed work, any additional costs incurred by Sourcewell and/or its Members as a result of such failure to proceed will be borne by the Vendor.

B. DEFAULT AND REMEDIES. Either of the following constitutes cause to declare this Contract, or any Member order under this Contract, in default:

1. Nonperformance of contractual requirements, or
2. A material breach of any term or condition of this Contract.

Written notice of default and a reasonable opportunity to cure must be issued by the party claiming default. Time allowed for cure will not diminish or eliminate any liability for liquidated or other damages. If the default remains after the opportunity for cure, the non-defaulting party may:

- Exercise any remedy provided by law or equity, or
- Terminate the Contract or any portion thereof, including any orders issued against the Contract.

20. INSURANCE

A. REQUIREMENTS. At its own expense, Vendor must maintain insurance policy(ies) in effect at all times during the performance of this Contract with insurance company(ies) licensed or authorized to do business in the State of Minnesota having an "AM BEST" rating of A- or better, with coverage and limits of insurance not less than the following:

1. Workers' Compensation and Employer's Liability.

Workers' Compensation: As required by any applicable law or regulation.

Employer's Liability Insurance: must be provided in amounts not less than listed below:

Minimum limits:

\$500,000 each accident for bodily injury by accident

\$500,000 policy limit for bodily injury by disease

\$500,000 each employee for bodily injury by disease

2. Commercial General Liability Insurance. Vendor will maintain insurance covering its operations, with coverage on an occurrence basis, and must be subject to terms no less broad than the Insurance Services Office ("ISO") Commercial General Liability Form CG0001 (2001 or newer edition). At a minimum, coverage must include liability arising from premises, operations, bodily injury and property damage, independent contractors, products-completed operations including construction defect, contractual liability, blanket contractual liability, and personal injury and advertising injury. All required limits, terms and conditions of coverage must be maintained during the term of this Contract.

Minimum Limits:

\$1,000,000 each occurrence Bodily Injury and Property Damage

\$1,000,000 Personal and Advertising Injury
\$2,000,000 aggregate for Products-Completed operations
\$2,000,000 general aggregate

3. **Commercial Automobile Liability Insurance.** During the term of this Contract, Vendor will maintain insurance covering all owned, hired, and non-owned automobiles in limits of liability not less than indicated below. The coverage must be subject to terms no less broad than ISO Business Auto Coverage Form CA 0001 (2010 edition or newer).

Minimum Limits:

\$1,000,000 each accident, combined single limit

4. **Umbrella Insurance.** During the term of this Contract, Vendor will maintain umbrella coverage over Workers' Compensation, Commercial General Liability, and Commercial Automobile.

Minimum Limits:

\$2,000,000

5. **Network Security and Privacy Liability Insurance.** During the term of this Contract, Vendor will maintain coverage for network security and privacy liability. The coverage may be endorsed on another form of liability coverage or written on a standalone policy. The insurance must cover claims which may arise from failure of Vendor's security resulting in, but not limited to, computer attacks, unauthorized access, disclosure of not public data – including but not limited to, confidential or private information, transmission of a computer virus, or denial of service.

Minimum limits:

\$2,000,000 per occurrence

\$2,000,000 annual aggregate

Failure of Vendor to maintain the required insurance will constitute a material breach entitling Sourcewell to immediately terminate this Contract for default.

B. **CERTIFICATES OF INSURANCE.** Prior to commencing under this Contract, Vendor must furnish to Sourcewell a certificate of insurance, as evidence of the insurance required under this Contract. Prior to expiration of the policy(ies), renewal certificates must be mailed to Sourcewell, 202 12th Street Northeast, P.O. Box 219, Staples, MN 56479 or sent to the Sourcewell Contract Administrator assigned to this Contract. The certificates must be signed by a person authorized by the insurer(s) to bind coverage on their behalf. All policies must include there will be no cancellation, suspension, non-renewal, or reduction of coverage without thirty (30) days' prior written notice to the Vendor.

Upon request, Vendor must provide to Sourcewell copies of applicable policies and endorsements, within ten (10) days of a request. Failure to request certificates of insurance by Sourcewell, or failure of Vendor to provide certificates of insurance, in no way limits or relieves Vendor of its duties and responsibilities in this Contract.

C. **ADDITIONAL INSURED ENDORSEMENT AND PRIMARY AND NON-CONTRIBUTORY INSURANCE CLAUSE.** Vendor agrees to name Sourcewell and its Members, including their officers, agents, and employees, as an additional insured under the Vendor's commercial general liability insurance policy with respect to liability arising out of activities, "operations," or "work" performed by or on behalf of Vendor, and products and completed operations of Vendor. The policy provision(s) or endorsement(s) must further provide that coverage is primary and not excess over or contributory with any other valid, applicable, and collectible insurance or self-insurance in force for the additional insureds.

D. **WAIVER OF SUBROGATION.** Vendor waives and must require (by endorsement or otherwise) all its insurers to waive subrogation rights against Sourcewell and other additional insureds for losses paid under the insurance policies required by this Contract or other insurance applicable to the Vendor or its subcontractors. The waiver must apply to all deductibles and/or self-insured retentions applicable to the required or any other insurance maintained by the Vendor or its subcontractors. Where permitted by law, Vendor must require similar written express waivers of subrogation and insurance clauses from each of its subcontractors.

E. **UMBRELLA/EXCESS LIABILITY.** The limits required by this Contract can be met by either providing a primary policy or in combination with umbrella/excess liability policy(ies).

F. **SELF-INSURED RETENTIONS.** Any self-insured retention in excess of \$10,000 is subject to Sourcewell's approval.

21. COMPLIANCE

A. **LAWS AND REGULATIONS.** All Equipment, Products, or Services provided under this Contract must comply fully with applicable federal laws and regulations, and with the laws in the states and provinces in which the Equipment, Products, or Services are sold.

B. **LICENSES.** Vendor must maintain a valid status on all required federal, state, and local licenses, bonds, and permits required for the operation of the business that the Vendor conducts with Sourcewell and Members.

22. BANKRUPTCY, DEBARMENT, OR SUSPENSION CERTIFICATION

Vendor certifies and warrants that it is not in bankruptcy or that it has previously disclosed in writing certain information to Sourcewell related to bankruptcy actions. If at any time during this Contract Vendor declares bankruptcy, Vendor must immediately notify Sourcewell in writing.

Vendor certifies and warrants that neither it nor its principals are presently debarred, suspended, proposed for debarment, declared ineligible, or voluntarily excluded from programs

operated by the State of Minnesota, the United States federal government, or any Member. Vendor certifies and warrants that neither it nor its principals have been convicted of a criminal offense related to the subject matter of this Contract. Vendor further warrants that it will provide immediate written notice to Sourcewell if this certification changes at any time.

23. PROVISIONS FOR NON-UNITED STATES FEDERAL ENTITY PROCUREMENTS UNDER UNITED STATES FEDERAL AWARDS OR OTHER AWARDS

Members that use United States federal grant or FEMA funds to purchase goods or services from this Contract may be subject to additional requirements including the procurement standards of the Uniform Administrative Requirements, Cost Principles and Audit Requirements for Federal Awards, 2 C.F.R. § 200. Members may also require additional requirements based on specific funding specifications. Within this Article, all references to “federal” should be interpreted to mean the United States federal government. The following list only applies when a Member accesses Vendor’s Equipment, Products, or Services with United States federal funds.

A. **EQUAL EMPLOYMENT OPPORTUNITY.** Except as otherwise provided under 41 C.F.R. § 60, all contracts that meet the definition of “federally assisted construction contract” in 41 C.F.R. § 60-1.3 must include the equal opportunity clause provided under 41 C.F.R. §60-1.4(b), in accordance with Executive Order 11246, “Equal Employment Opportunity” (30 FR 12319, 12935, 3 C.F.R. §, 1964-1965 Comp., p. 339), as amended by Executive Order 11375, “Amending Executive Order 11246 Relating to Equal Employment Opportunity,” and implementing regulations at 41 C.F.R. § 60, “Office of Federal Contract Compliance Programs, Equal Employment Opportunity, Department of Labor.” The equal opportunity clause is incorporated herein by reference.

B. **DAVIS-BACON ACT, AS AMENDED (40 U.S.C. § 3141-3148).** When required by federal program legislation, all prime construction contracts in excess of \$2,000 awarded by non-federal entities must include a provision for compliance with the Davis-Bacon Act (40 U.S.C. § 3141-3144, and 3146-3148) as supplemented by Department of Labor regulations (29 C.F.R. § 5, “Labor Standards Provisions Applicable to Contracts Covering Federally Financed and Assisted Construction”). In accordance with the statute, contractors must be required to pay wages to laborers and mechanics at a rate not less than the prevailing wages specified in a wage determination made by the Secretary of Labor. In addition, contractors must be required to pay wages not less than once a week. The non-federal entity must place a copy of the current prevailing wage determination issued by the Department of Labor in each solicitation. The decision to award a contract or subcontract must be conditioned upon the acceptance of the wage determination. The non-federal entity must report all suspected or reported violations to the federal awarding agency. The contracts must also include a provision for compliance with the Copeland “Anti-Kickback” Act (40 U.S.C. § 3145), as supplemented by Department of Labor regulations (29 C.F.R. § 3, “Contractors and Subcontractors on Public Building or Public Work Financed in Whole or in Part by Loans or Grants from the United States”). The Act provides that each contractor or subrecipient must be prohibited from inducing, by any means, any person

employed in the construction, completion, or repair of public work, to give up any part of the compensation to which he or she is otherwise entitled. The non-federal entity must report all suspected or reported violations to the federal awarding agency. Vendor must be in compliance with all applicable Davis-Bacon Act provisions.

C. **CONTRACT WORK HOURS AND SAFETY STANDARDS ACT (40 U.S.C. § 3701-3708).** Where applicable, all contracts awarded by the non-federal entity in excess of \$100,000 that involve the employment of mechanics or laborers must include a provision for compliance with 40 U.S.C. § 3702 and 3704, as supplemented by Department of Labor regulations (29 C.F.R. § 5). Under 40 U.S.C. § 3702 of the Act, each contractor must be required to compute the wages of every mechanic and laborer on the basis of a standard work week of 40 hours. Work in excess of the standard work week is permissible provided that the worker is compensated at a rate of not less than one and a half times the basic rate of pay for all hours worked in excess of 40 hours in the work week. The requirements of 40 U.S.C. § 3704 are applicable to construction work and provide that no laborer or mechanic must be required to work in surroundings or under working conditions which are unsanitary, hazardous or dangerous. These requirements do not apply to the purchases of supplies or materials or articles ordinarily available on the open market, or contracts for transportation or transmission of intelligence. This provision is hereby incorporated by reference into this Contract. Vendor certifies that during the term of an award for all contracts by Sourcewell resulting from this procurement process, Vendor must comply with applicable requirements as referenced above.

D. **RIGHTS TO INVENTIONS MADE UNDER A CONTRACT OR AGREEMENT.** If the federal award meets the definition of “funding agreement” under 37 C.F.R. § 401.2(a) and the recipient or subrecipient wishes to enter into a contract with a small business firm or nonprofit organization regarding the substitution of parties, assignment or performance of experimental, developmental, or research work under that “funding agreement,” the recipient or subrecipient must comply with the requirements of 37 C.F.R. § 401, “Rights to Inventions Made by Nonprofit Organizations and Small Business Firms Under Government Grants, Contracts and Cooperative Agreements,” and any implementing regulations issued by the awarding agency. Vendor certifies that during the term of an award for all contracts by Sourcewell resulting from this procurement process, Vendor must comply with applicable requirements as referenced above.

E. **CLEAN AIR ACT (42 U.S.C. § 7401-7671Q.) AND THE FEDERAL WATER POLLUTION CONTROL ACT (33 U.S.C. § 1251-1387).** Contracts and subgrants of amounts in excess of \$150,000 require the non-federal award to agree to comply with all applicable standards, orders or regulations issued pursuant to the Clean Air Act (42 U.S.C. § 7401- 7671q) and the Federal Water Pollution Control Act as amended (33 U.S.C. § 1251- 1387). Violations must be reported to the Federal awarding agency and the Regional Office of the Environmental Protection Agency (EPA). Vendor certifies that during the term of this Contract will comply with applicable requirements as referenced above.

F. **DEBARMENT AND SUSPENSION (EXECUTIVE ORDERS 12549 AND 12689).** A contract award (see 2 C.F.R. § 180.220) must not be made to parties listed on the government wide exclusions in

the System for Award Management (SAM), in accordance with the OMB guidelines at 2 C.F.R. §180 that implement Executive Orders 12549 (3 C.F.R. § 1986 Comp., p. 189) and 12689 (3 C.F.R. § 1989 Comp., p. 235), "Debarment and Suspension." SAM Exclusions contains the names of parties debarred, suspended, or otherwise excluded by agencies, as well as parties declared ineligible under statutory or regulatory authority other than Executive Order 12549. Vendor certifies that neither it nor its principals are presently debarred, suspended, proposed for debarment, declared ineligible, or voluntarily excluded from participation by any federal department or agency.

G. BYRD ANTI-LOBBYING AMENDMENT, AS AMENDED (31 U.S.C. § 1352). Vendors must file any required certifications. Vendors must not have used federal appropriated funds to pay any person or organization for influencing or attempting to influence an officer or employee of any agency, a member of Congress, officer or employee of Congress, or an employee of a member of Congress in connection with obtaining any federal contract, grant, or any other award covered by 31 U.S.C. § 1352. Vendors must disclose any lobbying with non-federal funds that takes place in connection with obtaining any federal award. Such disclosures are forwarded from tier to tier up to the non-federal award. Vendors must file all certifications and disclosures required by, and otherwise comply with, the Byrd Anti-Lobbying Amendment (31 U.S.C. § 1352).

H. RECORD RETENTION REQUIREMENTS. To the extent applicable, Vendor must comply with the record retention requirements detailed in 2 C.F.R. § 200.333. The Vendor further certifies that it will retain all records as required by 2 C.F.R. § 200.333 for a period of three (3) years after grantees or subgrantees submit final expenditure reports or quarterly or annual financial reports, as applicable, and all other pending matters are closed.

I. ENERGY POLICY AND CONSERVATION ACT COMPLIANCE. To the extent applicable, Vendor must comply with the mandatory standards and policies relating to energy efficiency which are contained in the state energy conservation plan issued in compliance with the Energy Policy and Conservation Act.

J. BUY AMERICAN PROVISIONS COMPLIANCE. To the extent applicable, Vendor must comply with all applicable provisions of the Buy American Act. Purchases made in accordance with the Buy American Act must follow the applicable procurement rules calling for free and open competition.

K. ACCESS TO RECORDS (2 C.F.R. § 200.336). Vendor agrees that duly authorized representatives of a federal agency must have access to any books, documents, papers and records of Vendor that are directly pertinent to Vendor's discharge of its obligations under this Contract for the purpose of making audits, examinations, excerpts, and transcriptions. The right also includes timely and reasonable access to Vendor's personnel for the purpose of interview and discussion relating to such documents.

L. PROCUREMENT OF RECOVERED MATERIALS (2 C.F.R. § 200.322). A non-federal entity that is

a state agency or agency of a political subdivision of a state and its contractors must comply with Section 6002 of the Solid Waste Disposal Act, as amended by the Resource Conservation and Recovery Act. The requirements of Section 6002 include procuring only items designated in guidelines of the Environmental Protection Agency (EPA) at 40 C.F.R. § 247 that contain the highest percentage of recovered materials practicable, consistent with maintaining a satisfactory level of competition, where the purchase price of the item exceeds \$10,000 or the value of the quantity acquired during the preceding fiscal year exceeded \$10,000; procuring solid waste management services in a manner that maximizes energy and resource recovery; and establishing an affirmative procurement program for procurement of recovered materials identified in the EPA guidelines.

24. CANCELLATION

Sourcewell or Vendor may cancel this Contract at any time, with or without cause, upon sixty (60) days' written notice to the other party. However, Sourcewell may cancel this Contract immediately upon discovery of a material defect in any certification made in Vendor's Proposal. Termination of this Contract does not relieve either party of financial, product, or service obligations incurred or accrued prior to termination.

Sourcewell
DocuSigned by:
By: Jeremy Schwartz
C0FD2A139D06489...
Jeremy Schwartz
Title: Director of Operations & Procurement/CPO
Date: 10/30/2019 | 8:29 AM CDT

Shaw Industries, Inc.
DocuSigned by:
By: Darrien Munroe
48D7E282A6BA405...
Darrien Munroe
Title: Contract Specialist
Date: 11/1/2019 | 7:42 AM CDT

Approved:
DocuSigned by:
By: Chad Coauette
7E42B8F817A64CC...
Chad Coauette
Title: Executive Director/CEO
Date: 10/30/2019 | 8:31 AM CDT

RFP#080819 - Flooring Materials with Related Supplies and Services

Vendor Details

Company Name: Shaw Industries, Inc.
Does your company conduct business under any other name? If yes, please state: Shaw Contract, Patcraft
Address: 616 East Walnut Avenue
Dalton, 30721 GA
Contact: Brande Poulnot
Email: brande.poulnot@shawinc.com
Phone: 770-387-7284
Fax: 770-387-7856
HST#: 35-2162582

Submission Details

Created On: Monday June 17, 2019 15:26:31
Submitted On: Thursday August 08, 2019 15:00:07
Submitted By: Chaz Wolfenbarger
Email: chaz.wolfenbarger@shawinc.com
Transaction #: 0644f85d-f95f-4d53-9a23-6fb9a5a93f35
Submitter's IP Address: 104.129.206.83

Specifications

Proposer Identity & Authorized Representatives

Line Item	Question	Response
1	Proposer Legal Name (and applicable d/b/a, if any):	Shaw Industries, Inc.
2	Proposer Address:	616 E. Walnut Ave. Dalton, GA 30721
3	Proposer website address:	www.shawinc.com
4	Proposer's Authorized Representative (name, title, address, email address & phone) (The representative must have authority to sign the "Proposer's Assurance of Compliance" on behalf of the Proposer):	Robert M. Chandler, Executive Vice President, Commercial Division bob.chandler@shawinc.com 706.532.3470 616 E. Walnut Ave. Dalton, GA 30721
5	Proposer's primary contact for this proposal (name, title, address, email address & phone):	Randa Thayer, VPSA, Government randa.thayer@shawinc.com 770-241-0910 616 E. Walnut Ave. Dalton, GA 30721
6	Proposer's other contacts for this proposal, if any (name, title, address, email address & phone):	Karen Kramer, VPSA, Government karen.kramer@shawinc.com 206-437-1540 616 E. Walnut Ave. Dalton, GA 30721

Company Information and Financial Strength

Line Item	Question	Response
7	Provide a brief history of your company, including your company's core values, business philosophy, and industry longevity related to the requested equipment, products or services.	Shaw started in 1946 as Star Dye Company and transitioned to carpet manufacturing in 1967. Shaw emerged as a public company in 1971. Throughout the next decade, our strategy was to build a vertical supply chain so we could control our quality from start to finish. By 1989, we were the largest carpet manufacturer in the world. Because of our dominant market share, strong management team, innovative thinking, and quality performance, Berkshire Hathaway acquired us in 2001. Today, we are a full-service flooring company with 22,000 employees around the globe and products for every flooring category, including broadloom, carpet tile, resilient, hardwood, laminate, and tile and stone flooring products and synthetic turf. Our key values are honesty, integrity, and passion.
8	Provide a detailed description of the products and services that you are offering in your proposal.	We are providing products and installation services for those products. Additionally, we will be offering maintenance services through SOILD. Our products include broadloom, carpet tile, resilient, engineered wood, and hardwood.
9	What are your company's expectations in the event of an award?	We would meet with your staff to finalize the marketing plan and reporting, We want you to be comfortable with our staff and plan going forward.
10	Demonstrate your financial strength and stability with meaningful data. This could include such items as financial statements, SEC filings, credit and bond ratings, letters of credit, and detailed reference letters. Upload supporting documents (as applicable) in the document upload section of your response.	We are a subsidiary of Berkshire Hathaway. Attached is Berkshire's annual report. In addition, we are happy to provide our Shaw specific financials upon receipt of a non-disclosure agreement from you. An NDA is attached for your signature.
11	What is your US market share for the solutions that you are proposing?	(Requested) Our US market share for commercial products is: Broadloom Carpet Tile Resilient Wood
12	What is your Canadian market share, if any?	(Requested) Our Canadian market share for commercial products is: Broadloom Carpet Tile Resilient Wood
13	Has your business ever petitioned for bankruptcy protection? If so, explain in detail.	No
14	How is your organization best described: is it a manufacturer, a distributor/dealer/reseller, or a service provider? Answer whichever question (either a) or b) just below) best applies to your organization. a) If your company is best described as a distributor/dealer/reseller (or similar entity), provide your written authorization to act as a distributor/dealer/reseller for the manufacturer of the products proposed in this RFP. If applicable, is your dealer network independent or company owned? b) If your company is best described as a manufacturer or service provider, describe your relationship with your sales and service force and with your dealer network in delivering the products and services proposed in this RFP. Are these individuals your employees, or the employees of a third party?	Shaw is primarily a manufacturer of floorcovering products. We also provide installation services for those products. We have 22,000 employees globally involved in all aspects of production and sales. We have 300 sales representatives in the US and Canada who are employees. We also have an inhouse service team. The only services we outsource are installation and maintenance, although we manage their work through our Shaw Integrated Solutions division.
15	If applicable, provide a detailed explanation outlining the licenses and certifications that are both required to be held, and actually held, by your organization (including third parties and subcontractors that you use) in pursuit of the business contemplated by this RFP.	Shaw has business licenses in each of our locations. When we hire an installation company, we vet their licenses.
16	Provide all "Suspension or Disbarment" information that has applied to your organization during the past ten years.	There are none.
17	Within this RFP category there may be subcategories of solutions. List subcategory titles that best describe your products and services.	There are none.

Industry Recognition & Marketplace Success

Line Item	Question	Response
18	Describe any relevant industry awards or recognition that your company has received in the past five years	<p>Patcraft</p> <p>2019:</p> <ul style="list-style-type: none"> - Best of Neocon Gold - Deconstructed Felt - Carpet Modular - Best of Neocon Gold - Handloom - Resilient - Metropolis Likes for Handloom - Buildings' Product Innovation for Deconstructed Felt - Interior + Sources HiP award for Subtle Impressions. - Coverage in Contract, Metropolis, Specify, Interior Design, Interiors + Sources, Archiproducts, Floor Covering News, Floor Covering Weekly, Floor Trends Magazine, Floor Focus, Green Operations, McMorrow Reports, and Office Insight. <p>2018:</p> <ul style="list-style-type: none"> - Adex Platinum - Deconstructed Metal - Adex Platinum - Material Paradox - Adex Platinum - Subtractive Layers - Adex Gold - AdMix - Adex Gold - Isle of Skye - MetropolisLikes - Artefact - Best of NeoCon Silver - Dichroic - Carpet Modular - School Planning & Management and College Planning and Management New Product of the Year - Tangible Hue - Interior Design Best of Year Awards Honoree - Dichroic - HiP Honoree Manufacturer: Seller - Megghan Hoyt - HiP Honoree Workplace: Flooring: Hard Surface - Woodtone - Product Innovations Merit Award (2nd Place) - Artefact - Davey Award (Silver) Websites-Construction for Websites - Shaw Sound Advisor <p>2017:</p> <ul style="list-style-type: none"> - Best of Neocon Silver - Hardsurface - Subtractive Layers - Buildings Product Innovation Grand Award (1st place) - Subtractive Layers - HiP Product Designer "Rising Star" - Kelly Stewart <p>2016:</p> <ul style="list-style-type: none"> - Best of Neocon Silver – Healthcare – AdMix - Floor Covering Weekly's GreenStep Awards Honoree – Deconstructed Black - Nightingale Silver - Hard Surface - AdMix - Nightingale Silver - Resilient - Vinings <p>Shaw Contract</p> <p>2019:</p> <ul style="list-style-type: none"> - IIDA/HD Product Design Competition – Best Carpet/Rugs – Community -Contract's Best of NeoCon Award – Silver, Modular Flooring – Suited - Mixology Award – Product of the Year, Flooring – Inside Shapes - IIDA GlobalShop Product Design Competition – Best Flooring – Natural Choreography <p>2018:</p> <ul style="list-style-type: none"> - Metropolis Likes – Haven - Contract's Best of NeoCon Award – Gold, Modular Flooring – Haven - Healthcare Design's Nightingale Award – Gold, Modular Flooring – Haven - Interior Design Magazine HiP Award – Best Workplace Flooring – Inside Shapes - Interior Design Magazine's Best of the Year Award – Carpet – Inside Shapes - Dezeen's Product Award Longlist – Inside Shapes - IIDA/HD Product Design Competition – Best Resilient Flooring – Natural Choreography - Contract's Best of NeoCon Award – Silver, Hard Surface – Natural Choreography - Healthcare Design's Nightingale Award – Silver, Hard Surface – Natural Choreography - GlobalShop's Best Flooring and Best of Competition – Canvas <p>2017:</p> <ul style="list-style-type: none"> - IIDA/HD Product Design Competition Winner – Best in Flooring – Carpet – Off the Grid <p>2016:</p> <ul style="list-style-type: none"> - Best of NeoCon Silver Award – Carpet Broadloom – Modern Edit - NeoCon Editor's Choice Award – LVT – Modern Edit - Best of NeoCon Gold – Compose Design Tool - Architizer Award – The Studio/Painting - The Sleep Event BCFA – Product of the Year Award – Noble Materials - GlobalShop Best of Flooring – Noble Materials <p>In 2019, Shaw Industries as a whole was ranked #3 on Forbes list for the Best Employers in the state of Georgia. We also made the Official Shipper of the Choice list in 2019.</p> <p>Corporate awards in 2017 are:</p> <ul style="list-style-type: none"> - GE Ecomagination Leadership Award-Clear Path Recycling - GE Return on Environment Award-Clear Path Recycling - Sustainable Purchasing Leadership Council (SPLC) 2017 Purchasing Leadership Awards

		<ul style="list-style-type: none"> — Market Transformation Leadership Award — Supplier Leadership Award - Floor Covering News Awards of Excellence - Environmental Leadership Award - USGBC LEED Gold: Shaw Contract - New York Showroom - USGBC LEED Silver: Shaw Contract - Atlanta Showroom - Selling Power magazine - 50 Best Companies to Sell For - eLearning! magazine - Learning 100 - Training magazine - 2017 Training Top 125
19	What percentage of your sales are to the governmental sector in the past three years	2016: 7.9% 2017: 8.8% 2018: 9.1%
20	What percentage of your sales are to the education sector in the past three years	2016: 16.8% 2017: 18.1% 2018: 20.2%
21	List any state or cooperative purchasing contracts that you hold. What is the annual sales volume for each of these contracts over the past three years?	<p>We are currently on contract with Sourcewell as well as 6 other cooperatives.</p> <p>KCDA Keystone Purchasing Network - KPN Massachusetts Higher Education Consortium - MHEC Panhandle Area Educational Consortium - PAEC Purchasing Association of Cooperative Entities - PACE Purchasing Cooperative of America - PCA</p> <p>We have the following state contracts which are: Kentucky, Massachusetts, Pennsylvania, Virginia, Alaska, Arizona, California, Colorado, Connecticut, Delaware, Florida, Iowa, Kansas, Louisiana, Michigan, Minnesota, Mississippi, Missouri, Nevada, New Jersey, New York, North Carolina, Ohio, Oregon, South Dakota, Tennessee, Utah, Vermont, Washington, and West Virginia.</p> <p>Our client information is confidential. We do not share their sales numbers. In turn, we would not share Sourcewell's numbers.</p>
22	List any GSA contracts that you hold. What is the annual sales volume for each of these contracts over the past three years?	<p>We have the following Government Purchasing Contract: GSA</p> <p>Our client information is confidential. We do not share their sales numbers. In turn, we would not share Sourcewell's numbers.</p>

References/Testimonials

Line Item 23.

Entity Name *	Contact Name *	Phone Number *
Department of Management Services, Florida	Victoria Mitchell victoria.mitchell@dms.myflorida.com	850.921.6014
Cabarrus County	Monty Eudy mdeudy@cabarruscounty.us	704.920.3216
City of Port St. Lucie	Wendy Ritacco writacco@cityofpsl.com	772.873.6367

Top Five Government or Education Customers

Line Item 24. Provide a list of your top five government, education, or non-profit customers (entity name is optional), including entity type, the state or province the entity is located in, scope of the project(s), size of transaction(s), and dollar volumes from the past three years.

Entity Name	Entity Type *	State / Province *	Scope of Work *	Size of Transactions *	Dollar Volume Past Three Years *
Sourcewell	Government	Minnesota - MN	Flooring Material and Full Turnkey material and installation services.	Confidential	Confidential
GSA	Government	District of Columbia - DC	Flooring Material and Full Turnkey material and installation services.	Confidential	Confidential
State of Oregon	Government	Oregon - OR	Flooring Material and Full Turnkey material and installation services.	Confidential	Confidential
State of Ohio	Government	Ohio - OH	Flooring Material and Full Turnkey material and installation services.	Confidential	Confidential
NASPO	Non-Profit	Kentucky - KY	Flooring Material and Full Turnkey material and installation services.	Confidential	Confidential

Ability to Sell and Deliver Service Nationwide

Describe your company's capability to meet the needs of Sourcewell Members across the US, and Canada if applicable. Your response should address in detail at least the following areas: locations of your network of sales and service providers, the number of workers (full-time equivalents) involved in each sector, whether these workers are your direct employees (or employees of a third party), and any overlap between the sales and service functions.

Line Item	Question	Response
25	Sales force.	We have more than 500 highly trained sales professionals throughout the US and Canada. Our qualified professionals are strategically located to best support our customers. They are equipped to provide our customers with best-in-class design, product, and overall customer support.
26	Dealer network or other distribution methods.	Your members will have easy access to products. We sell directly to customers or through dealers. We currently do business with thousands of dealers in the US and Canada.
27	Service force.	Surveys in Floor Focus rank Shaw as number one in service. Service is generally provided by our sales team; however, we have a technical services team of 39 employees, 18 of which can provide on-site support. These technical experts provide testing, installation support, and maintenance support.
28	Describe in detail the process and procedure of your customer service program, if applicable. Include your response-time capabilities and commitments, as well as any incentives that help your providers meet your stated service goals or promises.	Our sales and technical service teams typically respond within 24 hours. We have general manufacturing times of carpet in 4 weeks, carpet tile in 6 weeks and resilient with no lead time (products are in stock). Standard delivery is typically within 5 days. When an order is placed, our customer service representatives provide specific delivery dates. As a vertically integrated company, we own and operate the largest private trucking fleet in the flooring industry. Additionally, we have hundreds of services providers throughout the U.S. These vital resources help us to meet our service goals.
29	Identify any geographic areas of the United States that you will NOT be fully serving through the proposed contract.	We service all areas.
30	Identify any Sourcewell Member sectors (i.e., government, education, not-for-profit) that you will NOT be fully serving through the proposed contract. Explain in detail. For example, does your company have only a regional presence, or do other cooperative purchasing contracts limit your ability to promote another contract?	We will serve all sectors.
31	Define any specific contract requirements or restrictions that would apply to our Members in Hawaii and Alaska and in US Territories.	We do not provide installation or maintenance services in US territories.

Marketing Plan

Line Item	Question	Response
32	Describe your marketing strategy for promoting this contract opportunity. Upload representative samples of your marketing materials (if applicable) in the document upload section of your response.	Setting the correct price is a key part of our strategy: too low and our sales team is not motivated to sell, too high and our customers are not properly served. So we think very carefully about our pricing. Because we are the largest carpet manufacturer and one of the largest flooring manufacturers, we manage many contracts and understand what works. We have three brands on your contract and each has a marketing manager. Kieren Corcoran with Patcraft, Michelle Carpenter with Shaw Contract and Quentin Quathamer with Philadelphia Commercial will develop and implement the marketing plan for the Sourcewell contract. First, operationally, your contract will be available on our internal site 24/7 for our sales representatives to use and updated in all of our data systems. Then, our main marketing avenues are web calls, email blasts, Facebook, Twitter, Pinterest, Instagram, YouTube, flyers, and trade shows. Attached are some marketing materials we have used in the past.
33	Describe your use of technology and digital data (e.g., social media, metadata usage) to enhance marketing effectiveness.	We will consider all of our social media channels for your marketing plan: email blasts, Facebook, Twitter, Pinterest, Instagram, and YouTube. We track metadata for our media marketing outlets to determine our most effective messaging content.
34	In your view, what is Sourcewell's role in promoting contracts arising out of this RFP? How will you integrate a Sourcewell-awarded contract into your sales process?	We have been very pleased with our relationship. We appreciate your flexibility and responsiveness. This is the most important thing you bring to the sales process. As you know, we manage many contracts. You are one of our oldest and largest buying cooperatives and our sales representatives are already familiar with your contract. Your contract and marketing material will be available on-line for our sales teams. We will host a web call with our representatives outlining the contract, presenting the marketing materials and answering questions. Shaw's three marketing managers will alert sales representatives when we attend trade shows so they can participate. The marketing managers will be available to assist representatives with any questions along the way.
35	Are your products or services available through an e-procurement ordering process? If so, describe your e-procurement system and how governmental and educational customers have used it.	Yes, your members can order through EDI.

Value-Added Attributes

Line Item	Question	Response
36	Describe any product, equipment, maintenance, or operator training programs that you offer to Sourcewell Members. Include details, such as whether training is standard or optional, who provides training, and any costs that apply.	We have the most robust service team in the industry. We provide free installation and maintenance training to Sourcewell Members. First, we provide written instruction. Second, we provide video instruction. This is particularly helpful when bringing on new staff. Finally, we can arrange for on-site training.
37	Describe any technological advances that your proposed products or services offer.	Our EcoWorx carpet tile is PVC free, which is important to those members reducing their dependence on PVC. Our LokDots dry adhesive tabs make installation quicker and there is less waste than with wet adhesive. LokWorx dry adhesive tabs allow members to build their own rugs with carpet tile, a popular option for those installing hard surface flooring to reduce the noise. We offer a new wet adhesive that members can use for carpet or resilient flooring, and the pail is resealable. It can be reused up to 3 times. This saves storage space and simplifies the installation process. Our new, lightweight, StrataWorx carpet tiles are well suited when your members need a carpet tile at a broadloom price.
38	Describe any "green" initiatives that relate to your company or to your products or services, and include a list of the certifying agency for each.	<p>Our company green initiatives are:</p> <ul style="list-style-type: none"> - Products designed to be recyclable and to use less material - Manufacturing processes that continually reduce our impact on the environment - less water, less energy, and less waste. - Simple recycling services for our customers <p>Our progress is reported annually in our sustainability report at https://shawinc.com/Newsroom#Sustainability-Reports.</p> <p>Our carpet tile manufacturing facilities are ISO 14001 certified (environmental) and ISO 9001 certified (quality) by BSN. (environmental and quality respectively). Our commercial manufacturing facilities are carbon neutral.</p> <p>To help our customers assess our products, we provide:</p> <ul style="list-style-type: none"> *Health Product Declarations (health impact) *Environmental Product Declarations (environmental Impact) *Declare Labels (showing our ingredients)
39	Identify any third-party issued eco-labels, ratings or certifications that your company has received for the equipment or products included in your Proposal related to energy efficiency or conservation, life-cycle design (cradle-to-cradle), or other green/sustainability factors.	<p>Our product certifications include:</p> <ul style="list-style-type: none"> *Cradle to Cradle Certification by the Innovation Institute (carpet) *NSF 140 certification from ANSI (carpet) *Green Label Plus (air quality) from The Carpet and Rug Institute *FloorScore certification from SCS Global Services (for resilient) *SmartWay certification for the efficient use of fuel
40	Describe any Women or Minority Business Entity (WMBE), Small Business Entity (SBE), or veteran owned business certifications that your company or hub partners have obtained. Upload documentation of certification (as applicable) in the document upload section of your response.	As a private company owned by a corporation Berkshire Hathaway, we do not qualify as a minority enterprise.
41	What unique attributes does your company, your products, or your services offer to Sourcewell Members? What makes your proposed solutions unique in your industry as it applies to Sourcewell members?	Dealers, designers and facility managers consistently rank Shaw's service and quality as the best in the industry. Our products are on the cutting edge of innovation and the 35 people in our service division are available to answer questions, provide testing or arrange training.
42	Identify your ability and willingness to provide your products and services to Sourcewell member agencies in Canada.	We provide Sourcewell agencies in Canada with the same level of service as the US with the exception of installation services.

Warranty

Describe in detail your manufacturer warranty program, including conditions and requirements to qualify, claims procedure, and overall structure. You may upload representative samples of your warranty materials (if applicable) in the document upload section of your response in addition to responding to the questions below.

Line Item	Question	Response
43	Do your warranties cover all products, parts, and labor?	Yes, we offer detailed warranties on each of our products, including lifetime warranties on our EcoWorx tile products. We also provide a workmanship warranty for our installation services.
44	Do your warranties impose usage restrictions or other limitations that adversely affect coverage?	Yes, you must install the product according to instructions and you must maintain the products according to maintenance instructions. These instructions are available on the website, through the dealer, and through our customer service department.
45	Do your warranties cover the expense of technicians' travel time and mileage to perform warranty repairs?	Yes.
46	Are there any geographic regions of the United States (and Canada, if applicable) for which you cannot provide a certified technician to perform warranty repairs? How will Sourcewell Members in these regions be provided service for warranty repair?	No.
47	Will you cover warranty service for items made by other manufacturers that are part of your proposal, or are these warranties issues typically passed on to the original equipment manufacturer?	We cover the warranty service for all of the products we sell.
48	What are your proposed exchange and return programs and policies?	If you cancel your running line product prior to shipping, there is no restock or cancellation fee. If your order has shipped, you will incur restocking and freight fees. For broadloom under 75 feet, the charge is 25% of the invoice plus freight. For broadloom over 75 feet, the charge is 15% of the invoice plus freight. For carpet tile, the charge is 25% plus freight. If we ship products in error or with defective material, your products will be returned at no charge. We will replace your order as soon as possible. If there are special circumstances related to the cancellation, we will work with you to minimize costs.
49	Describe any service contract options for the Items included in your proposal.	We are only offering products in this proposal.

Payment Terms and Financing Options

Line Item	Question	Response
50	What are your payment terms (e.g., net 10, net 30)?	Net 30
51	Do you provide leasing or financing options, especially those options that schools and governmental entities may need to use in order to make certain acquisitions?	No.
52	Briefly describe your proposed order process. Include enough detail to support your ability to report quarterly sales to Sourcewell as described in the Contract template. For example, indicate whether your dealer network is included in your response and whether each dealer (or some other entity) will process the Sourcewell Members' purchase orders.	<p>We have a comprehensive ordering process for each type of flooring transaction: Material-only orders, Turnkey orders, and Dealer Material-only orders. The process for each of these is as follows:</p> <p>Material ONLY orders Customer emails SIS with order request listing: Customer Information, Bill to address, Job name, Shaw Product, and Adhesive. SIS - creates a proposal and sends it to the customer / end-user for review. If the customer accepts the proposal, the customer will need to issue a formal purchase order back to SIS. SIS - processes the order and emails customer with stock/backorder information, along with an order confirmation and live order tracking link. Material is shipped to the customer. SIS - Customer is invoiced and pays SIS per the invoice.</p> <p>Turnkey orders Customer emails SIS with order request listing: Customer Information, Bill to address, Job name, Shaw Product, Adhesive. (The Installation vendor can send this as well if they are working directly with the customer) Installation Vendor provides labor quote SIS - creates a turnkey proposal and sent to the Customer / End-user If the customer accepts the proposal, the customer will need to issue a formal purchase order back to SIS. SIS - processes the order and emails customer and installer with stock/backorder information, along with an order confirmation and live order tracking link. Material is shipped out to the Installation Vendor or customer. (Depends on storage at the job site) SIS - work order and customer work release forms are sent to installation vendor When the job is completed, the signed work order and customer work release are sent to SIS SIS - pays the installation vendor SIS - send the customer is invoiced and pays SIS per the invoice.</p> <p>Dealer Material ONLY The dealer sends the customer proposal for material and labor services (if needed). The dealer sends SIS a PO for "material only" (This is for reporting to Sourcewell) (Dealer must sign a dealer participation agreement, if one is not on file, SIS will provide) Dealer PO must have the following information: - Sourcewell Member number and member name - Shaw Industries Contract # 121715 SIS processes the order and emails the dealer with stock/backorder information, along with an order confirmation and live order tracking link. Dealer is invoiced for Shaw material.</p> <p>We have four SIS points of contacts for different regions: - Melanie Taylor - Southeast, South Central, West Coast, HI & AK o Email: melanie.taylor@shawinc.com o Phone:770-276-7502 - Rosio Hernandez - North Central, Northeast, and Northwest o Email: rosio.hernandez@shawinc.com o Phone: 770-276-7511 - Crystal Zachery - New York & Florida o Email: crystal.zachery@shawinc.com o Phone: 706-276-7509 - Farrah Finley - Canada o Email: farrah.finley@shawinc.com o Phone: 770-276-7505</p>
53	Do you accept the P-card procurement and payment process? If so, is there any additional cost to Sourcewell Members for using this process?	Yes, we do accept a P-card. There is a fee of 2%

Pricing and Delivery

Provide detailed pricing information in the questions that follow below. Keep in mind that reasonable price and product adjustments can be made during the term of an awarded Contract as described in the RFP, the template Contract, and the Sourcwell Price and Product Change Request Form.

Line Item	Question	Response *
54	Describe your pricing model (e.g., line-item discounts or product-category discounts). Provide detailed pricing data (including standard or list pricing and the Sourcwell discounted price) on all of the items that you want Sourcwell to consider as part of your RFP response. If applicable, provide a SKU for each item in your proposal. Upload your pricing materials (if applicable) in the document upload section of your response.	We are providing line-item discounts. On our submittal, we show the list price, the discount, and the agency price. We do show the product name and number but not a specific SKU. An SKU would be specific to the color level.
55	Quantify the pricing discount represented by the pricing proposal in this response. For example, if the pricing in your response represents a percentage discount from MSRP or list, state the percentage or percentage range.	Our discount is per item and on our pricing sheet, we show that discount percentage.
56	Describe any quantity or volume discounts or rebate programs that you offer.	We are not offering any quantity or volume discounts on this contract; however, it is a not-to-exceed price. On a case by case basis, we would extend a volume discount. That number varies based on the specific product, location, and delivery requirements.
57	Propose a method of facilitating "sourced" products or related services, which may be referred to as "open market" items or "nonstandard options". For example, you may supply such items "at cost" or "at cost plus a percentage," or you may supply a quote for each such request.	If we source items for your members, there is no charge. If we source services, which are more involved, we charge our customer cost plus 12%.
58	Identify any element of the total cost of acquisition that is NOT included in the pricing submitted with your response. This includes all additional charges associated with a purchase that are not directly identified as freight or shipping charges. For example, list costs for items like pre-delivery inspection, installation, set up, mandatory training, or initial inspection. Identify any parties that impose such costs and their relationship to the Proposer.	This price is direct to your member. It does not include dealer handling cost, freight or taxes.
59	If freight, delivery, or shipping is an additional cost to the Sourcwell Member, describe in detail the complete freight, shipping, and delivery program.	Freight costs are not included in the member price and will be listed separately on purchase orders and invoices. Freight costs will be fully disclosed to your member prior to order placement and will be prepaid by the Contractor.
60	Specifically describe freight, shipping, and delivery terms or programs available for Alaska, Hawaii, Canada, or any offshore delivery.	Shaw uses partner carriers to deliver to Hawaii, Alaska, and Canada. For Hawaii customers, our Los Angeles distribution center delivers the product to our partner's dock and is shipped twice a week. For Alaska customers, our Seattle distribution center delivers the product to our partner's dock and ships twice weekly to Alaska. Shaw ships to Canada daily from our North Georgia hub distribution centers using our core partner carrier which has terminals in all major cities in Canada.
61	Describe any unique distribution and/or delivery methods or options offered in your proposal.	For customers on the west coast, we can offer rail delivery which is likely less expensive but may not be as timely.

Pricing Offered

Line Item	The Pricing Offered in this Proposal Is:	Comments
62	b. the same as the Proposer typically offers to GPOs, cooperative procurement organizations, or state purchasing departments.	

Audit and Administrative Fee

Line Item	Question	Response *
63	Specifically describe any self-audit process or program that you plan to employ to verify compliance with your proposed Contract with Sourcwell. This process includes ensuring that Sourcwell Members obtain the proper pricing, that the Vendor reports all sales under the Contract each quarter, and that the Vendor remits the proper administrative fee to Sourcwell.	Darrien Munroe is your contract administrator and he verifies that the information submitted by our Shaw Integrated Solutions Team is correct.
64	Identify a proposed administrative fee that you will pay to Sourcwell for facilitating, managing, and promoting the Sourcwell Contract in the event that you are awarded a Contract. This fee is typically calculated as a percentage of Vendor's sales under the Contract or as a per-unit fee; it is not a line-item addition to the Member's cost of goods. (See the RFP and template Contract for additional details.)	2%

Industry Specific Questions

Line Item	Question	Response
65	Describe how your products contribute to or promote the health, quality of life and well-being of our members and others.	We show our members how our products contribute to health, quality of life and wellbeing by certifying our products to the highest levels, including: Cradle to Cradle Certification (life cycle certification for carpet) NSF 140 certification (life cycle certification for carpet) Green Label Plus certification (low emissions for carpet) FloorScore certification (life cycle and low emissions for hard surface) For transparency, we also provide Health Product Declarations, Environmental Product Declarations and Declare labels for our products. These certifications are listed on our specifications.
66	Describe your capability to track and report sales to Sourcewell members by your dealer network.	Our sales team will work with your members to ensure that all of their orders go through Shaw Integrated Solutions (SIS). This team of 5 people ensures that the order is coded to Sourcewell. After this information is captured, SIS routes the order to: - the dealer as an order to the dealer to receive and deliver - Shaw as a direct order delivered to the member - Shaw as a turnkey project managed by SIS where the Shaw entity supplies material and installation.
67	Describe how your organization incorporates sustainability into the manufacture, installation and recycling of your products?	Shaw begins with the end in mind. We design our products on the front end to use less material and to be easier to recycle. Our manufacturing processes are continually refined to use less water, less energy and to produce less waste. We report this progress annually in our sustainability report which is available at https://shawinc.com/Newsroom#Sustainability-Reports
68	Describe your capability to report Sourcewell member purchases of products with environmentally preferred attributes (e.g., eco labeled, rated or certified).	Reporting is managed by Darrien Munroe. Darrien pulls the data and formats it for your reports. We can report purchases of environmentally preferred products; however, that includes most of our products.
69	Describe the extent to which your products contain recycled content or are recyclable.	All of our EcoWorx products are recyclable. They contain 27-47% recycled content. Our other broadloom carpet products contain up to 14% recycled content. The exact numbers are reflected on our specifications. LVT and vinyl sheet have no recycled content and are not recyclable. Wood products contain up to 50% recycled content and can be recycled. Tile and stone have no recycled content and are not recyclable; however, they are made from a plentiful natural resource. Sustainability metrics have moved away from recycled content because recycled content can introduce contaminants and the reclamation market is weak. The emphasis today is on healthy materials.

Exceptions to Terms, Conditions, or Specifications Form

Line Item 68. NOTICE: To identify any exception, or to request any modification, to the Sourcewell template Contract terms, conditions, or specifications, a Proposer must submit the exception or requested modification on the **Exceptions to Terms, Conditions, or Specifications Form** immediately below. The contract section, the specific text addressed by the exception or requested modification, and the proposed modification must be identified in detail. Proposer's exceptions and proposed modifications are subject to review and approval of Sourcewell and will not automatically be included in the contract.

Contract Section	Term, Condition, or Specification	Exception or Proposed Modification
1st paragraph	This Contract is between Sourcewell, 202 12th Street Northeast, P.O. Box 219, Staples, MN 56479 (Sourcewell) and [Name and Address of Vendor to be Inserted Upon Contract Award] (Vendor).	This Contract is between Sourcewell, 202 12th Street Northeast, P.O. Box 219, Staples, MN 56479 (Sourcewell) and Shaw Industries, Inc., 616 E.Walnut Avenue, Dalton, GA 30721 (Vendor).
Section 2C	C. WARRANTY. Vendor warrants that all Equipment, Products, and Services furnished are free from liens and encumbrances, and are free from defects in design, materials, and workmanship. In addition, Vendor warrants the Equipment, Products, and Services are suitable for and will perform in accordance with the ordinary use for which they are intended. Vendor's dealers and distributors must agree to assist the Member in reaching a resolution in any dispute over warranty terms with the manufacturer. Any manufacturer's warranty that is effective past the expiration of the Vendor's warranty will be passed on to the Member.	C. WARRANTY. Vendor warrants that all Equipment, Products, and Services furnished are free from liens and encumbrances, and, subject to the applicable generally-published manufacturer's limited product warranty, are free from defects in design, materials, and workmanship. Vendor's dealers and distributors must agree to assist the Member in reaching a resolution in any dispute over warranty terms with the manufacturer. Any manufacturer's warranty that is effective past the expiration of the Vendor's warranty will be passed on to the Member. EXCEPT AS EXPRESSLY SET FORTH HEREIN AND TO THE MAXIMUM EXTENT PERMITTED BY LAW, VENDOR MAKES NO OTHER WARRANTIES FOR ANY EQUIPMENT, PRODUCTS, SERVICES, OR MATERIALS PROVIDED UNDER THIS AGREEMENT AND HEREBY DISCLAIMS ALL OTHER WARRANTIES, EXPRESS OR IMPLIED, INCLUDING THE WARRANTY OF FITNESS FOR A PARTICULAR PURPOSE OR USE.
Section 3(B)	B. SALES TAX. Each Member is responsible for supplying the Vendor with valid tax-exemption certification(s). When ordering, Members must indicate if it is a tax-exempt entity.	B. SALES TAX. Each Member is responsible for supplying the Vendor with valid tax-exemption certification(s). When ordering, Members must indicate if it is a tax-exempt entity. Unless exempt, Members shall be responsible for all applicable taxes arising from the provision of Products, Equipment, or Services under this Agreement.

Section 4	Vendor may request Equipment, Product, or Service changes, additions, or deletions at any time. All requests must be made in writing by submitting a signed Sourcewell Price and Product Change Request Form to the assigned Sourcewell Contract Administrator. This form is available from the assigned Sourcewell Contract Administrator. At a minimum, the request must:	Vendor may request Equipment, Product, Service, or price changes, additions, or deletions at any time. All requests must be made in writing by submitting a signed Sourcewell Price and Product Change Request Form to the assigned Sourcewell Contract Administrator. Sourcewell's approval of such requests shall not be unreasonably withheld. Notwithstanding anything herein to the contrary, all Equipment, Product, and/or Service prices are subject to immediate increase without limitation in the event of a material change to applicable duties, taxes, tariffs, similar charges, or other government action. This form is available from the assigned Sourcewell Contract Administrator. At a minimum, the request must:
Section 5(A)	Vendor is responsible for familiarizing its sales and service forces with Sourcewell membership requirements and documentation and will encourage potential members to join Sourcewell. Sourcewell reserves the right to add and remove Members to its roster during the term of this Contract.	Vendor is responsible for familiarizing its sales and service forces with Sourcewell membership requirements and documentation. Sourcewell reserves the right to add and remove Members to its roster during the term of this Contract.
Section 6(A)	A. PURCHASE ORDERS AND PAYMENT. To access the contracted Equipment, Products, or Services under this Contract, Member must clearly indicate to Vendor that it intends to access this Contract; however, order flow and procedure will be developed jointly between Sourcewell and Vendor. Typically a Member will issue a purchase order directly to Vendor. Members may use their own forms for purchase orders, but it should clearly note the applicable Sourcewell contract number. Members will be solely responsible for payment and Sourcewell will have no liability for any unpaid invoice of any Member.	A. PURCHASE ORDERS AND PAYMENT. To access the contracted Equipment, Products, or Services under this Contract, Member must clearly indicate to Vendor that it intends to access this Contract; however, order flow and procedure will be developed jointly between Sourcewell and Vendor. Typically a Member will issue a purchase order directly to Vendor. Members may use their own forms for purchase orders, but it should clearly note the applicable Sourcewell contract number. Members shall be solely responsible for noting the applicable Sourcewell contract number on all purchase orders. Members will be solely responsible for payment and Sourcewell will have no liability for any unpaid invoice of any Member.
Section 6(B)	B. ADDITIONAL TERMS AND CONDITIONS. Additional terms and conditions to a purchase order may be negotiated between a Member and Vendor, such as job or industry-specific requirements, legal requirements (such as affirmative action or immigration status requirements), or specific local policy requirements. Any negotiated additional terms and conditions must never be less favorable to the Member than what is contained in Vendor's Proposal.	B. ADDITIONAL TERMS AND CONDITIONS. Additional terms and conditions to a purchase order may be negotiated between a Member and Vendor, such as job or industry-specific requirements, legal requirements (such as affirmative action or immigration status requirements), or specific local policy requirements.
Section 6(C)	C. PERFORMANCE BOND. If requested by a Member, Vendor will provide a performance bond that meets the requirements set forth in the Member's purchase order.	C. PERFORMANCE BOND. If reasonably requested by a Member, Vendor may provide a performance bond that meets the requirements set forth in the Member's purchase order.
Section 8(A)	"A. CONTRACT SALES ACTIVITY REPORT. Each calendar quarter, Vendor must provide a contract sales activity report (Report) to the Sourcewell Contract Administrator assigned to this Contract. A Report must be provided regardless of the number or amount of sales during that quarter (i.e., if there are no sales, Vendor must submit a report indicating no sales were made).	"A. CONTRACT SALES ACTIVITY REPORT. Subject to any applicable confidentiality obligations, including without limitation any contract obligations to Members, each calendar quarter, Vendor must provide a contract sales activity report (Report) to the Sourcewell Contract Administrator assigned to this Contract. A Report must be provided regardless of the number or amount of sales during that quarter (i.e., if there are no sales, Vendor must submit a report indicating no sales were made).

<p>Section 8(B)</p>	<p>"B. ADMINISTRATIVE FEE. In consideration for the support and services provided by Sourcewell, the Vendor will pay an administrative fee to Sourcewell on all Equipment, Products, and Services provided to Members. The Vendor will submit a check payable to Sourcewell for the percentage of administrative fee stated in the Proposal multiplied by the total sales of all Equipment, Products, and Services purchased by Members under this Contract during each calendar quarter. Payments should note the Sourcewell-assigned contract number in the memo and must be mailed to the address above "Attn: Accounts Receivable." Payments must be received no later than forty-five (45) calendar days after the end of each calendar quarter.</p> <p>Vendor agrees to cooperate with Sourcewell in auditing transactions under this Contract to ensure that the administrative fee is paid on all items purchased under this Contract.</p> <p>In the event the Vendor is delinquent in any undisputed administrative fees, Sourcewell reserves the right to cancel this Contract and reject any proposal submitted by the Vendor in any subsequent solicitation. In the event this Contract is cancelled by either party prior to the Contract's expiration date, the administrative fee payment will be due no more than thirty (30) days from the cancellation date."</p>	<p>"B. ADMINISTRATIVE FEE. In consideration for the support and services provided by Sourcewell, the Vendor will pay an administrative fee to Sourcewell on all Equipment, Products, and Services provided to Members under this Contract. The Vendor will submit a check payable to Sourcewell for the percentage of administrative fee stated in the Proposal multiplied by the total net sales of all Equipment, flooring Products, and Services purchased by Members under this Contract during each calendar quarter, less any applicable taxes, freight, fees, and discounts and less amounts attributable to any Services, freight, delivery installation, unpaid invoices, returned Products or materials, or credits issued. Orders under this Contract will only be eligible for the administrative fee if the Member notes the applicable Sourcewell contract number on the purchase order when submitting such purchase order. Payments should note the Sourcewell-assigned contract number in the memo and must be mailed to the address above "Attn: Accounts Receivable." Payments must be received no later than forty-five (45) calendar days after the end of each calendar quarter.</p> <p>Vendor agrees to reasonably cooperate with Sourcewell in auditing transactions under this Contract to solely to the extent necessary to verify that the administrative fee is paid on all eligible items purchased under this Contract in accordance with the terms of this Contract.</p> <p>In the event the Vendor is delinquent in any undisputed administrative fees, Sourcewell reserves the right to cancel this Contract and reject any proposal submitted by the Vendor in any subsequent solicitation. In the event this Contract is cancelled by either party prior to the Contract's expiration date, the administrative fee payment will be due no more than thirty (30) days from the cancellation date.</p> <p>Any Products, Equipment, or Services sold under this Contract will not be eligible for the Administrative Fee if subject to any other rebate or group purchasing organization administrative fee. Sourcewell s is solely responsible for notifying any Member or other entity participating hereunder of its Administrative Fee and for complying with all laws and regulations related or applicable to such Administrative Fee. "</p>
<p>Section 11</p>	<p>Vendor must indemnify, save, and hold Sourcewell and its Members, including their agents and employees, harmless from any claims or causes of action, including attorneys' fees, arising out of the performance of this Contract by the Vendor or its agents or employees; this indemnification includes injury or death to person(s) or property alleged to have been caused by some defect in the Equipment, Products, or Services under this Contract to the extent the Equipment, Product, or Service has been used according to its specifications.</p>	<p>Vendor must indemnify, save, and hold Sourcewell and its Members, including their agents and employees, harmless from any claims or causes of action, including attorneys' fees, brought against Sourcewell or its Member by a third party to the extent arising out of the negligent performance of this Contract by the Vendor or its agents or employees; this indemnification includes injury or death to person(s) or property alleged to have been caused by some defect in the Equipment, Products, or Services under this Contract to the extent the Equipment, Product, or Service has been used according to its specifications.</p>
<p>Section 12</p>	<p>Sourcewell reserves the right to review the books, records, documents, and accounting procedures and practices of the Vendor relevant to this Contract for a minimum of six (6) years from the end of this Contract. This clause extends to Members as it relates to business conducted by that Member under this Contract.</p>	<p>"Sourcewell reserves the right to review the books, records, documents, and accounting procedures and practices of the Vendor pursuant to this Contract solely to the extent necessary to verify Vendor's compliance with its obligations hereunder for a minimum of six (6) years from the end of this Contract. This clause extends to Members as it relates to business conducted by that Member under this Contract.</p> <p>Sourcewell and its Members agree to receive and hold Confidential Information of Vendor in trust and in strictest confidence and shall not use, reproduce, distribute, disclose, or otherwise disseminate any Confidential Information except 1) as necessary to perform its obligations hereunder or 2) as required by applicable law. Disclosures of the Confidential Information may be made only to Sourcewell or its Member's employees and agents who have a specific need to know such Confidential Information and are subject to confidentiality restrictions at least as restrictive as those contained herein. "Confidential Information" means all disclosures under this Section 12 or Section 8 as well as any non-public, confidential or proprietary information of Vendor, disclosed to Sourcewell or its Member through any method or medium, whether or not marked, designated or otherwise identified as ""confidential"" in connection with this Contract. Upon Vendor's request, Sourcewell or its Member shall promptly return or destroy all documents and other materials containing Confidential Information. The obligations and restrictions of this Section shall survive the expiration or earlier termination of the Agreement."</p>

Section 14	As applicable, Vendor agrees to indemnify and hold harmless Sourcewell and its Members against any and all suits, claims, judgments, and costs instituted or recovered against Sourcewell or Members by any person on account of the use of any Equipment or Products by Sourcewell or its Members supplied by Vendor in violation of applicable patent or copyright laws.	As applicable, Vendor agrees to indemnify and hold harmless Sourcewell and its Members against any and all suits, claims, judgments, and costs instituted or recovered against Sourcewell or Members by any person on account of the authorized use of any Equipment or Products by Sourcewell or its Members in accordance with their applicable specifications supplied by Vendor under this Contract in violation of applicable patent or copyright laws.
Section 19(A)(2)	2. Escalation. If parties are unable to resolve the issue in a timely manner, as specified above, either Sourcewell or Vendor may escalate the resolution of the issue to a higher level of management. The Vendor will have thirty (30) calendar days to cure an outstanding issue.	2. Escalation. If parties are unable to resolve the issue in a timely manner, as specified above, either Sourcewell or Vendor may escalate the resolution of the issue to a higher level of management. The Vendor will have not less than ninety (90) calendar days to cure an outstanding issue or default identified under Section 19(B).

Documents

Ensure your submission document(s) conforms to the following:

1. Documents in PDF format are preferred. Documents in Word, Excel, or compatible formats may also be provided.
2. Documents should NOT have a security password, as Sourcewell may not be able to open the file. It is your sole responsibility to ensure that the uploaded document(s) are not either defective, corrupted or blank and that the documents can be opened and viewed by Sourcewell.
3. Sourcewell may reject any response where any document(s) cannot be opened and viewed by Sourcewell.
4. If you need to upload more than one (1) document for a single item, you should combine the documents into one zipped file. If the zipped file contains more than one (1) document, ensure each document is named, in relation to the submission format item responding to. For example, if responding to the Marketing Plan category save the document as "Marketing Plan."

- [Financial Strength and Stability](#) - 2018 Berkshire Hathaway Inc.pdf - Friday August 02, 2019 14:29:07
- [Marketing Plan/Samples](#) - Marketing Plan.pdf - Wednesday August 07, 2019 15:41:29
- WMBE/MBE/SBE or Related Certificates (optional)
- [Warranty Information](#) - SC PC PCC Warranties -.pdf - Wednesday August 07, 2019 10:47:26
- [Pricing](#) - Shaw Soucewell Pricing 8-9-19.xlsx - Thursday August 08, 2019 14:59:00
- [Additional Document](#) - Sourcewell Exception . Modification (Shaw 8.2).xlsx - Thursday August 08, 2019 11:41:09

Proposers Assurance of Comp

PROPOSER ASSURANCE OF COMPLIANCE

PROPOSER'S AFFIDAVIT

The undersigned, authorized representative of the entity submitting the foregoing proposal (the "Proposer"), swears that the following statements are true to the best of his or her knowledge.

1. The Proposer is submitting its proposal under its true and correct name, the Proposer has been properly originated and legally exists in good standing in its state of residence, the Proposer possesses, or will possess before delivering any products and related services, all applicable licenses necessary for such delivery to Sourcewell member agencies. The undersigned affirms that he or she is authorized to act on behalf of, and to legally bind the Proposer to the terms in this Contract.
2. The Proposer, or any person representing the Proposer, has not directly or indirectly entered into any agreement or arrangement with any other vendor or supplier, any official or employee of Sourcewell, or any person, firm, or corporation under contract with Sourcewell, in an effort to influence the pricing, terms, or conditions relating to this RFP in any way that adversely affects the free and open competition for a Contract award under this RFP.
3. The contents of the Proposer's proposal have not been communicated by the Proposer or its employees or agents to any person not an employee or agent of the Proposer and will not be communicated to any such persons prior to the official opening of the proposals.
4. The Proposer has examined and understands the terms, conditions, scope, contract opportunity, specifications request, and other documents in this solicitation and affirms that any and all exceptions have been noted and included with the Proposer's Proposal.
5. The Proposer will, if awarded a Contract, provide to Sourcewell Members the /products and services in accordance with the terms, conditions, and scope of this RFP, with the Proposer-offered specifications, and with the other documents in this solicitation.
6. The Proposer agrees to deliver products and services through valid contracts, purchase orders, or means that are acceptable to Sourcewell Members. Unless otherwise agreed to, the Proposer must provide only new and first-quality products and related services to Sourcewell Members under an awarded Contract.
7. The Proposer will comply with all applicable provisions of federal, state, and local laws, regulations, rules, and orders.
8. The Proposer understands that Sourcewell will reject RFP proposals that are marked "confidential" (or "nonpublic," etc.), either substantially or in their entirety. Under Minnesota Statute §13.591, Subd. 4, all proposals are considered nonpublic data until the evaluation is complete and a Contract is awarded. At that point, proposals generally become public data. Minnesota Statute §13.37 permits only certain narrowly defined data to be considered a "trade secret," and thus nonpublic data under Minnesota's Data Practices Act.

The Proposer understands that it is the Proposer's duty to protect information that it considers nonpublic, and it agrees to defend and indemnify Sourcewell for reasonable measures that Sourcewell takes to uphold such a data designation.

By checking this box I acknowledge that I am bound by the terms of the Proposer's Affidavit, have the legal authority to submit this Proposal on behalf of the Proposer, and that this electronic acknowledgment has the same legal effect, validity, and enforceability as if I had hand signed the Proposal. This signature will not be denied such legal effect, validity, or enforceability solely because an electronic signature or electronic record was used in its formation.
- Robert Chandler, Executive Vice President, Commercial Division

The Proposer declares that there is an actual or potential Conflict of Interest relating to the preparation of its submission, and/or the Proposer foresees an actual or potential Conflict of Interest in performing the contractual obligations contemplated in the bid.

Yes No

The Bidder acknowledges and agrees that the addendum/addenda below form part of the Bid Document.

Check the box in the column "I have reviewed this addendum" below to acknowledge each of the addenda.

File Name	I have reviewed the below addendum and attachments (if applicable)	Pages
Addendum_7_RFP080819_Flooring Materials with Related Supplies and Services Fri July 26 2019 02:21 PM	✓	--
Addendum_6_Flooring Materials with REalted Supplies and SErVICES_RFP080819 Mon July 22 2019 01:46 PM	✓	--
Addendum_5_Flooring Materials with RElated Supplies and Services_RFP080819 Tue July 16 2019 04:11 PM	✓	--
Addendum_4_Flooring Materials with Related Supplies and Services_RFP_080819 Tue July 16 2019 08:49 AM	✓	--
Addendum_3_Flooring Materials with Related Supplies and Services_RFP_080819 Mon July 15 2019 03:56 PM	✓	--
Addendum_2_Flooring Materials with Related Supplies and Services_RFP_080819 Wed July 10 2019 03:01 PM	✓	--
Addendum_1_Flooring Materials with Related Supplies and Services_RFP#_080819 Tue July 2 2019 03:34 PM	✓	--

**AMENDMENT #1
TO
CONTRACT #080819-SII**

THIS AMENDMENT is effective upon the date of the last signature below by and between **Sourcewell** and **Shaw Industries, Inc.** (Vendor).

Sourcewell awarded a contract to Vendor to provide Flooring Materials, with Related Supplies and Services, to Sourcewell and its Participating Entities, effective November 1, 2019, through October 11, 2023 (Contract).

The parties wish to amend the following terms within the Contract:

Section 20. Insurance—Subsection A. Requirements— Item 5. Network Security and Privacy Liability Insurance, of the Contract, is deleted in its entirety.

Except as amended by this Amendment, the Contract remains in full force and effect.

Sourcewell

By: 
DocuSigned by:
C0FD2A139D06489...
Jeremy Schwartz, Director of Operations/CPO

Date: 10/12/2022 | 8:04 AM CDT

Approved:

By: 
DocuSigned by:
7E42B8F817A64CC...
Chad Coauette, Executive Director/CEO

Date: 10/12/2022 | 8:13 AM CDT

Shaw Industries, Inc.

By: 
DocuSigned by:
D8B140FCEE7242B...
Darrien Munroe

Title: Treasurer / CFO

Date: 10/11/2022 | 2:09 PM PDT

ASSIGNMENT AGREEMENT

THIS ASSIGNMENT AGREEMENT is by and between **Sourcewell; Shaw Industries, Inc.**, 616 East Walnut Avenue, Dalton, Georgia 30721 (“Shaw Industries”); and **Shaw Integrated and Turf Solutions, Inc. (“SITS”)**.

Sourcewell has agreements with Shaw Industries to provide Flooring Materials, with Related Supplies and Services under Sourcewell Contract Number 080819-SII (“Original Contract”).

Shaw Industries wishes to assign the Original Contract to SITS, a wholly owned subsidiary of Shaw Industries Group, Inc.

The Assignment provision of the Original Contract requires assignment of the contract only upon written consent of Sourcewell.

ASSIGNMENT

1. This Assignment Agreement will become effective as of the date of the last signature below.
2. Shaw Industries wishes to assign to SITS all of Shaw Industries’ rights, responsibilities, and other provisions set forth in the Original Contract, Sourcewell Contract Number 080819-SII.
3. SITS has obtained a copy of the Original Contract from Shaw Industries and certifies it will comply with the terms of the Original Contract as executed by Shaw Industries and Sourcewell. The parties agree this Assignment is unconditional and without recourse.
4. Shaw Industries and SITS jointly severally represent and warrant to Sourcewell that:
 - a. Shaw Industries is not in default of any of its obligations under the Original Contract.
 - b. SITS is ready, willing, and able to perform all of the obligations and responsibilities of the Original Contract.
 - c. Shaw Industries and SITS request consent from Sourcewell for this assignment.
 - d. SITS accepts assignment of the provisions of the Original Contract.

IN CONSIDERATION for the above, Sourcewell consents to the assignment.

Shaw Industries, Inc.

DocuSigned by:
James L. Kirkpatrick
By: _____
DB8140FCEE7242B...
Jim Kirkpatrick

Title: Treasurer / CFO

Date: 1/30/2023 | 12:33 PM PST

Shaw Integrated and Turf Solutions, Inc.

DocuSigned by:
James L. Kirkpatrick
By: _____
DB8140FCEE7242B...
Jim Kirkpatrick

Title: Vice President

Date: 1/30/2023 | 12:33 PM PST

Sourcewell

DocuSigned by:
Jeremy Schwartz
By: _____
C0FD2A139D06489...
Jeremy Schwartz
Director of Operations and Procurement/CPO

Date: 1/30/2023 | 3:22 PM CST

Sourcewell

DocuSigned by:
Chad Coquette
By: _____
7E42B8F817A64CC...
Chad Coquette
Executive Director/CEO

Date: 1/30/2023 | 3:28 PM CST

SUMMARY SHEET

RECOMMENDATION TO SUPERINTENDENT FOR SCHOOL BOARD AGENDA

AGENDA ITEM NO. 4c

DATE OF SCHOOL BOARD MEETING: October 10, 2023

TITLE OF AGENDA ITEM: Contractual agreement between Gadsden County District Schools and Ethica, LLC

DIVISION: Academic Services

 This is a CONTINUATION of a current project, grant, etc.

PURPOSE AND SUMMARY OF ITEM:

Ethica will provide professional services to Title I administration and management specifically in Federal compliance.

FUND SOURCE: Title I

AMOUNT: \$21,000

PREPARED BY: Tammy McGriff Farlin, EdS

POSITION: Assistant Superintendent, Academic Services PreK-12

INTERNAL INSTRUCTIONS TO BE COMPLETED BY PREPARER

1 Number of ORIGINAL SIGNATURES NEEDED by preparer.

SUPERINTENDENT'S SIGNATURE: page(s) numbered _____

CHAIRMAN'S SIGNATURE: page(s) numbered 5

REVIEWED BY: _____

INDEPENDENT CONTRACTOR AGREEMENT

This Contractor Agreement (“Agreement”) is entered into by and between Ethica, LLC (Ethica) and Gadsden County Public School District (GADSDEN COUNTY PUBLIC SCHOOLS) as of July 15, 2023.

Ethica, LLC is located at PO Box 1033, Quincy, FL 32353

Whereas, Ethica LLC possesses professional Title I administrator skills and education management experience that can assist GADSDEN COUNTY PUBLIC SCHOOLS in carrying out its legal duties under the Elementary and Secondary Education Act;

Whereas, GADSDEN COUNTY PUBLIC SCHOOLS wishes to engage Ethica to perform professional services for DISTRICT for purposes of (1) providing Title I grant writing and grants management consultation; and (2) supporting the expenditure of federal coronavirus funds in compliance with Federal and State of Florida law;

Therefore, for good and valuable consideration, the receipt and adequacy of which is acknowledged, Ethica and GADSDEN COUNTY PUBLIC SCHOOLS hereby agree as follows:

1. Description of Services

- A. Ethica will provide the professional services assigned by GADSDEN COUNTY PUBLIC SCHOOLS and more fully described in Attachment A (“Contracted Services”). Ethica acknowledges and agrees that time is of the essence in the value of the Contracted Services, and shall render such Contracted Services in a prompt and diligent manner.
- B. Changes to the Contracted Services may be made only through a signed written amendment to this Agreement, agreed on and signed by both parties.

2. Term

Ethica will provide the Contracted Services during the 2023-2024 school year unless this agreement is terminated earlier pursuant to Section 4 or extended by written agreement of the parties. Unless otherwise specified by GADSDEN COUNTY PUBLIC SCHOOLS in writing, Ethica shall provide the Contracted Services for the full duration of this Agreement. Ethica and District mutually agree to extend the term of this Agreement as may be needed.

3. Compensation

- A. GADSDEN COUNTY PUBLIC SCHOOLS will compensate Ethica pursuant to the provisions contained in Attachment B and this Section 3, and will not pay Ethica for any other benefits, expenses, or compensation.
- B. Total compensation for service will be \$21,000.00.

- C. GADSDEN COUNTY PUBLIC SCHOOLS will compensate Ethica within 30 days following the receipt of itemized billing statements from Ethica that satisfactorily describe the hours and dates that Ethica performed the Contracted Services, the services performed, and any expenses incurred. Ethica shall submit billing statements directly to the DISTRICT CONTRACT PERSON identified in Section 5.
- D. Upon termination of this Agreement, other than termination for cause under Section 4(b), Ethica will be entitled to receive compensation for Contracted Services satisfactorily provided prior to the effective date of termination.
- E. Changes to the compensation under this Agreement may be made only through a signed, written amendment to this Agreement.

4. Termination

- A. General: The term of this agreement is set forth in Section 2. The Agreement may be terminated before the end of the term pursuant to the following subsections of this Section 4.
- B. Termination for cause: This Agreement may be terminated immediately by either party following a material breach of this Agreement and a failure to cure such breach within a reasonable period not to exceed ten (10) business days.
- C. Termination for convenience: This Agreement may be terminated for convenience by either party at any time upon thirty (30) calendar days advance written notice.

5. Notices and Contact Persons

All written notices required by this agreement shall be sent to the following persons, who shall serve as Contact Person unless replaced by a party by written notice to the other party:

For Ethica, LLC:
Cheryl L. Sattler

For GADSDEN COUNTY PUBLIC SCHOOLS:
Joanette Thomas and Tammy McGriff

6. Approval of Contracted Services

Upon request by GADSDEN COUNTY PUBLIC SCHOOLS, Ethica shall provide written and oral reports to the GADSDEN COUNTY PUBLIC SCHOOLS contact person as may be reasonably necessary to assess performance, including a description of the average weekly hours worked under this Agreement. Services, once performed, are deemed accepted by GADSDEN COUNTY PUBLIC SCHOOLS.

7. Contractor Representation

Ethica represents that it is not presently debarred, suspended, proposed for debarment, declared ineligible, or voluntarily excluded from participation in transactions by any federal, state, or local governmental authority. Ethica shall immediately inform GADSDEN COUNTY PUBLIC SCHOOLS regarding the circumstances if this representation becomes no longer accurate during the term of this Agreement.

8. Standards of Conduct

- A. Ethica shall comply with all applicable laws, rules, regulations, and standards of ethical conduct, including those relating specifically to the performance of the Contracted Services under this Agreement.
- B. Ethica shall comply with general principles of confidentiality and with the specific terms of a confidentiality agreement, if relevant.

9. Relationship of the Parties

- A. The parties agree that Ethica is an independent contractor, and that neither it nor any of its employees is an employee, agent, partner, or joint venture of GADSDEN COUNTY PUBLIC SCHOOLS
- B. Ethica shall secure and maintain all insurance, licenses, and/or permits necessary to perform the Contracted Services. Ethica shall be solely responsible for paying its employees, and for paying all applicable state and federal taxes. Ethica understands that neither it nor its employees will be eligible for benefits or privileges provided by GADSDEN COUNTY PUBLIC SCHOOLS to its employees.
- C. GADSDEN COUNTY PUBLIC SCHOOLS shall deliver to Ethica statements of income at the end of each tax year consistent with its contractor status.
- D. Ethica has complete and exclusive authority over the means and methods of performing the Contracted Services, need not adhere to policies and procedures applicable to GADSDEN COUNTY PUBLIC SCHOOLS employees, and may perform the Contracted Services according to its own schedule at its own offices or at any other location. Ethica shall hire its own employees, use its own tools and equipment, and purchase its own supplies.
- E. Ethica has no authority to, and shall not purport to, bind, represent, or speak for District or otherwise incur any obligation on behalf of GADSDEN COUNTY PUBLIC SCHOOLS for any purpose unless expressly authorized by GADSDEN COUNTY PUBLIC SCHOOLS.

10. Record Maintenance

- A. With respect to all records of any kind that Ethica acquires or creates for purposes of performing the Contracted Services, Ethica shall comply with the record retention plan established by GADSDEN COUNTY PUBLIC SCHOOLS shall not knowingly destroy records that are required to be preserved, and shall maintain project records in an orderly manner.

- B. Ethica shall make available to district upon request all records relating to the subcontracted services, including records relating to its invoices.
- C. Ethica shall cooperate with GADSDEN COUNTY PUBLIC SCHOOLS in the event of any audit relating to the Contracted Services.

11. Insurance

- A. Ethica shall maintain during the term of this Agreement such insurance as will fully protect both GADSDEN COUNTY PUBLIC SCHOOLS and Ethica from claims that may arise from Ethica's performance of the Contracted Services.

12. Waiver

The failure of a party to enforce a provision of this agreement shall not constitute a waiver with respect to that provision or any other provision of this Agreement.

13. Merger

This Agreement (including the attachments) constitutes the entire agreement between the parties with respect to the subject matter of the Contracted Services, and supersedes all prior agreements and understandings, both written and oral.

14. Severability

If any provision in this Agreement is found by a court of competent jurisdiction to be invalid or unenforceable, the remaining provisions in this Agreement shall continue in full force and effect.

15. Governing Law

The parties agree that this Agreement is governed by the laws of Florida. The parties also consent to jurisdiction in its courts, and agree that such courts shall have exclusive jurisdiction over the enforcement of this Agreement.

16. Authority to Sign

Each party represents that it has the authority to enter into this Agreement; and that the individual signing this Agreement on its behalf is authorized to bind the party.

17. Multiple Originals

Multiple copies of this contract executed separately will each be considered as originals.

	For Ethica, LLC
Name	Cheryl L. Sattler J.D., Ph.D.
Title	Senior Partner
Signature	
Date	
	For GADSDEN COUNTY PUBLIC SCHOOLS
Name	
Title	
Signature	
Date	

Attachment A: Scope of Work

Membership in FedNet and CARESNet. Services described below will be provided for (1) Title I; and (2) federal coronavirus relief grants.

Training

- Member meetings to exchange ideas, solve problems, and network (3x year).
- Webinars and conference calls on topics of interest to members (minimum of 4).
- Annual one-day training in preparing for monitoring for districts either undergoing monitoring or in the year prior to monitoring. (If relevant, estimate 2 days).
- Printed and electronic material dissemination, including Federal guidance and interpretation documents (as published/available, estimate 6x annual)

Services

- Mentoring of ESEA administrators (ongoing, estimate 4 issues/year)
- A moderated email listserv so members can quickly exchange information and have questions answered (ongoing, estimate 12 times/year).
- Annual funding application support (estimate 2 issues/year)
- Unlimited Q&A by email or phone (ongoing, estimate 6x year)
- Model documents (as needed, estimate 1x year)
- Recommendations and logistics support for “best practices” (as needed, estimate 1x year)
- Research support (as needed, estimate 1x year)
- Connections to national organizations (access to ESSA webinars, conference notes, etc. Estimate 6x year).
- Negotiation for multi-district services such as consultants, publications, and interventions (as needed, estimate 1x year)
- Advocacy with state and federal departments of education (ongoing, estimate 10 x year)

Deliverables

- Regular Washington updates (Minimum 6x year)
- Access to National Title I Conference video library (unlimited access, 100+ available)
- Meeting summaries:
 - FASFEPA (2x year)
 - FOIL (Florida Organization of Instructional Leaders; 2x year)
 - State Board of Education (5x year)
 - National Title I Conference (1x year)

- Florida Legislative education bills (relevant to federal programs; minimum 6x year)

Grant News

Regular e-mail updates of Federal news and information (minimum 5x year)

ATTACHMENT B: Compensation

Compensation for services will be \$21,000, payable upon invoice.

SUMMARY SHEET

RECOMMENDATION TO SUPERINTENDENT FOR SCHOOL BOARD AGENDA

AGENDA ITEM NO. 5a

DATE OF SCHOOL BOARD MEETING: October 10, 2023

TITLE OF AGENDA ITEM: GCHS Agriculture Students

DIVISION: Academic Services

_____ This is a CONTINUATION of a current project, grant, etc.

PURPOSE AND SUMMARY OF ITEM:

(Type and Double Space)

According to School Board Policy 2340 (Field and Other District-Sponsored Trips), all out-of-state field trips must be approved by the School Board. The Gadsden County High School Agriculture students are requesting approval for an out-of-state field trip to attend the Ag Expo in Moultrie, GA.

Please see attached documentation.

FUND SOURCE: N/A

AMOUNT: N/A

PREPARED BY: Tammy McGriff 

POSITION: Assistant Superintendent, Academic Services PreK-12

INSTRUCTIONS TO BE COMPLETED BY PREPARER

_____ Number of ORIGINAL SIGNATURES NEEDED by preparer.

SUPERINTENDENT'S SIGNATURE: page(s) numbered _____

CHAIRMAN'S SIGNATURE: page(s) numbered _____



THE SCHOOL BOARD OF GADSDEN COUNTY

FIELD TRIP REQUEST

FORM MUST BE RECEIVED IN DISTRICT OFFICE 2 WEEKS PRIOR TO TRIP

DATE OF REQUEST: 09/25/2023	SCHOOL: Gadsden County High School	CONTACT FOR FIELD TRIP: Eric Toussaint
---------------------------------------	--	--

DATE OF TRIP: 10/18/2023	WHO IS ATTENDING: (grade/organization) Gadsden County Agriculture Students
------------------------------------	--

LOCATION: Sunbelt Ag Expo 290-G Harper Boulevard Moultrie, GA 31788-2157	TRAVELING BY: <input checked="" type="checkbox"/> School Bus/District Vehicle <input type="checkbox"/> Charter Bus
--	---

PURPOSE: Youth Educational Challenges, Exposure to the Agriculture Industry Advancements, and view college opportunities for agriculture

FUNDING source of this field trip: Please mark and "X" in the appropriate box

Students	X	Fundraiser		School/District Budget	X
----------	---	------------	--	------------------------	---

- SCHOOL BUS –Required items for approval:**
1. Principal’s signature
 2. Complete list of participants and chaperones
 3. Signed Permission Form for each participant.
 4. Complete final itinerary
 5. Documentation showing correlation of the Florida Standards or benchmark to the field trip request

- CHARTER BUS–Required items for approval:**
1. Principal’s signature
 2. Complete list of participants and chaperones
 3. Signed Permission Form for each participant.
 4. Complete final itinerary
 5. Copy of charter bus contract with signatures
 6. Proof of Insurance showing either district or school as insured

Signature of Person Requesting Trip

Approval Principal (Signature required)

APPROVED DENIED

Superintendent/Designee Date

Please forward the completed form via email, district mail or fax:
 Mrs. Eureka Fields, Program Assistant for Instructional Services
 Fax: (850) 627-3530 Email: fieldse@gcpsmail.com

GADSDEN FFA CHAPTER

27001 Blue Star Memorial Hwy, Havana, FL 32333

Phone: (850) 662-2300

Fax: (850) 539-2863

website: www.gchs.gcps.k12.fl.us



Chelsea Franklin, Principal
Eric Toussaint, FFA Advisor

O'Hara Black, Assistant Principal
Elijah Key, Superintendent

State of Florida Standards and Benchmarks used

CTE Standards and Benchmarks

FS-M/LA

NGSSS-Sci

National Standards

08.01 Develop, implement, and maintain work based learning through Supervised Agricultural Experiences (SAE).

CS.01.01.01.a

08.05 Demonstrate interpersonal (nonverbal) communication skills.

08.06 Demonstrate good listening skills.

09.02 Identify opportunities to apply acquired leadership skills.

CRP.09.01.02.a

09.03 Identify and demonstrate ways to be an active citizen.

CRP.01.03.02.c

09.07 Identify the opportunities for leadership development available through the National FFA Organization and/or professional organizations.

JACKSONVILLE ZOO FIELD TRIP PERMISSION SLIP

Dear Parent or Guardian:

An educational field trip has been scheduled and was approved by the school. *Students who do not have prior written permission will not be able to participate in the field trip. Students are required to be in proper dress code for this trip.*

PLEASE NOTE THE FOLLOWING REGARDING THE FIELD TRIP:

Where: Ag Expo, Moultrie, GA

Trip Date: Oct 18, 2023

Departure From School: 8:00 am

Return To School: 5:30 pm

- 1) I have been informed of the details of this educational field experience.
- 2) I agree to instruct my child to obey all school rules, regulations and instructions given by the teacher and/or authorized school personnel. I further agree that no teacher or authorized personnel shall be held responsible or liable for injuries or other mishaps caused by my child's deliberate disobedience of rules, regulations or instructions.
- 3) This field experience is considered as school work and will be conducted as a regular class.
- 4) I agree to have transportation arranged for my child at the end of the trip.

THIS TRIP IS PLANNED TO EXTEND A UNIT OF STUDY WITHIN THE SCHOOL CURRICULUM

YOUR SIGNATURE INDICATES THAT YOU HAVE READ AND AGREE TO THE ABOVE

❖ _____ I give permission for my child to participate in the Field Trip on October 18, 2023.

❖ _____ I **DO NOT** give permission for my child to participate in the Field Trip on October 18, 2023.

(Student's Name)

(Parent or Guardian Signature)

Phone Number: _____

Emergency Contact: _____

(Name)

(Number)

GADSDEN FFA CHAPTER

27001 Blue Star Memorial Hwy, Havana, FL 32333

Phone: (850) 662-2300

Fax: (850) 539-2863

website: www.chs.cps.k12.fl.us

Chelsea Franklin, Principal
Eric Toussaint, FFA Advisor

O'Hara Black, Assistant Principal
Elijah Key, Superintendent

AG EXPO AGENDA OCTOBER 1

- 08:00 AM- DEPART GADSDEN COUNTY HIGH SCHOOL
- 10:00 AM- ARRIVE AT AG EXPO
- 10:00 AM- YOUTH EDUCATIONAL OPPORTUNITIES
- 12:00 PM- LUNCH
- 12:30 PM- YOUTH EDUCATIONAL OPPORTUNITIES
- 02:00 PM- YEO AWARD CEREMONY
- 03:30 PM- DEPART TO RETURN
- 05:30 PM- ARRIVE GADSDEN COUNTY HIGH SCHOOL



2023

Youth Educational Challenges

Sponsored by Country Financial

Overview

- 1) The Youth Educational Challenges will be Wednesday, October 18, 2023, at the Sunbelt Ag Expo
 - a) Time slots are available online from 9:00 a.m. – 1:00 p.m.
 - i) Register Early! Time slots will be filled on a first-come, first-serve basis. When time slots are full, they are full.
 - b) All participating students will receive lunch compliments of Agri Supply Company and Coke.
 - c) An awards ceremony will be held in the RW Griffin Building at 2:00 p.m.
- 2) Challenges are open to any student, 6th – 12th grade
 - a) Students may participate as a member of an FFA or 4-H chapter or as a student unaffiliated with any youth organization.
 - b) There will be a Junior Division (6th – 9th grade) and a Senior Division (10th-12th grade).
 - c) Students will compete as individuals.
- 3) Students are eligible to compete in as many of the challenges as they can fit into their schedules for the day.
- 4) There will be five content area competitions with a Junior and a Senior Division.
 - a) Ag Business
 - b) Ag Mechanics
 - c) Animal Science
 - d) Forestry & ENR
 - e) Plant Science
- 5) Awards will be given to 1st - 3rd place in each content area in Junior and Senior Divisions.
 - a) Additional award
 - i) The chapter/dub with the most participants
- 6) Students are required to register online for the challenges by Friday, October 6th.
 - a) Registration must be completed at sunbeltexpo.com/yeo by selecting the registration link for the Youth Educational Challenges



- 7) Students are NOT required to wear official dress. Comfortable, yet appropriate, respectable clothing is recommended.
- 8) To study, students may use any reference they so choose. In addition, it is recommended that students consult sources listed on the Georgia Ag Ed website, www.gaaged.org, regarding similar categories associated with CDE competitions.
- 9) Regarding Scoring:
 - a) Because there will only be one part to each challenge, participant scores will be the sum of the answers they get correct.
 - b) In the case of a tie,
 - i) (1) there will be tie-breaker questions at the end of the required questions that will only be used for breaking ties.
 - ii) (2) Individual questions within the challenge will be determined in advance as tie-breakers.

GADSDEN FFA CHAPTER

27001 Blue Star Memorial Hwy, Havana, FL 32333

Phone: (850) 662-2300

Fax: (850) 539-2863

website: www.gchs.gcps.k12.fl.us

Chelsea Franklin, Principal
Eric Toussaint, FFA Advisor

Elijah Key, Superintendent

AG EXPO

Students

[REDACTED]

[REDACTED]

Chaperones

ERIC TOUSSAINT

THURMAN STUBBS

PRISCILLA JACKSON-CLARK

DENNIS MOYE

*Student and Chaperones
List May Change

SUMMARY SHEET

RECOMMENDATION TO SUPERINTENDENT FOR SCHOOL BOARD

AGENDA AGENDA ITEM NO. 5b

DATE OF SCHOOL BOARD MEETING: October 10, 2023

TITLE OF AGENDA ITEM: 2023-2024 Code of Student Conduct

DIVISION: School Safety

X This is a CONTINUATION of a current project, grant, etc.

PURPOSE AND SUMMARY OF ITEM:

The Office of School and Safety is requesting the approval of the 2023-2024 Student Code of Conduct. Changes from the 2022-2023 Student Code of Conduct are highlighted in yellow.

FUND SOURCE: NA

AMOUNT: \$0

PREPARED BY: Officer Tiffany Buckhalt 

POSITION: District School Safety Coordinator

INTERNAL INSTRUCTIONS TO BE COMPLETED BY PREPARER

_____ Number of ORIGINAL SIGNATURES NEEDED by preparer.

SUPERINTENDENT'S SIGNATURE: page(s) numbered _____

CHAIRMAN'S SIGNATURE: page(s) numbered _____

Gadsden County School District

2023-2024

CODE OF STUDENT CONDUCT



Elijah Key

SUPERINTENDENT OF SCHOOLS
35 MARTIN LUTHER KING, JR. BLVD
QUINCY, FLORIDA 32351
TEL: (850) 627-9651
FAX: (850) 627-2760
www.gadsdenschools.org

Board Approved
00/00/0000

CATHY S. JOHNSON
DISTRICT NO. 1
HAVANA, FL 32333
MIDWAY, FL 32343

STEVE SCOTT
DISTRICT NO. 2
QUINCY, FL 32351
HAVANA, FL 32333

LEROY McMILLAN.
DISTRICT NO. 3
CHATTAHOOCHEE, FL 32324
GREENSBORO, FL 32330

CHARLIE D. FROST
DISTRICT NO. 4
GRETNA, FL 32332
QUINCY, FL 32352

KAREMA D. DUDLEY
DISTRICT NO. 5
QUINCY, FL 32353

"The Gadsden County School District does not discriminate against any person on the basis of sex (including transgender status, gender nonconforming, and gender identity), marital status, sexual orientation, race, religion, ethnicity, national origin, age, color, pregnancy, disability, or genetic information."

TABLE OF CONTENTS

SUPERINTENDENT'S MESSAGE.....	3
JURISDICTION OF THE SCHOOL BOARD.....	4
DISCRIMINATION STATEMENT	4
PLEDGE OF ALLEGIANCE.....	4
STUDENTS' RIGHTS AND RESPONSIBILITIES	5
I. ATTENDANCE.....	5
DISTRICT ATTENDANCE GOAL	5
II. RESPECT FOR PERSONS AND PROPERTY.....	7
III. RIGHT TO LEARN.....	8
IV. RIGHT OF ASSEMBLY	8
V. RIGHT OF PRIVACY	9
VI. PARTICIPATION IN SCHOOL PROGRAMS AND ACTIVITIES	9
VII. DRESS AND GROOMING.....	10
VIII. WIRELESS COMMUNICATION DEVICES.....	12
IX. DISCRIMINATION/SEXUAL HARASSMENT	14
X. COUNSELING	14
XI. FREE SPEECH AND PUBLICATION	15
XII. STUDENT GOVERNMENT.....	15
XIII. STUDENT RECORDS	16
XIV. GRADES.....	20
GENERAL DISCIPLINARY PROCEDURES	20
I. PRESENCE OF PUPILS, WHEN AND WHERE AUTHORIZED	20
II. AUTHORITY OF THE TEACHER	20
III. OFFENSES	21
IV. DEFERRED PUNISHMENT FOR OFFENSES	22
BULLYING AND HARASSMENT – Gadsden School Board Policy #5517.01.....	22
DUE PROCESS PROCEDURES FOR SUSPENSION/EXPULSION OF STUDENTS WITH DISABILITIES	30
A. Suspension	31
B. Expulsion.....	31
PROCEDURES FOR THE DISCIPLINE OF STUDENTS WITH DISABILITIES	32
PROCEDURES FOR THE DISCIPLINE OF PREKINDERGARTEN STUDENTS	32
DISCIPLINARY PROCEDURES GRADES K-12.....	33
ZERO TOLERANCE OFFENSES.....	36
Offenses Prohibited.....	37
WEAPONS PROHIBITED	38
CERTAIN DRUGS PROHIBITED.....	39
PROCEDURES FOR STUDENT TRANSFER-FELONY CHARGES.....	39
SUSPENSION/EXPULSION.....	40
CORPORAL PUNISHMENT	42
REASONABLE FORCE.....	42
COLLECTION OF EVIDENCE / SEARCH AND SEIZURE.....	43
AUTHORITY OF THE SCHOOL BUS DRIVER.....	44
MISCONDUCT ON SCHOOL BUSES.....	44
ENROLLMENT OF STUDENTS EXPELLED/DISMISSED FROM OTHER SCHOOL DISTRICTS OR PRIVATE SCHOOLS	45
GLOSSARY	46
APPENDICES	53
Declaration of Intent to Terminate School Enrollment	54
Compulsory Attendance Requirements	54
School Violence: Suggested Prevention By District Safety Committee	62
BULLYING AND HARASSMENT FORMS.....	62
CLASSROOM BEHAVIOR MANAGEMENT FORM FOR MINOR OFFENSES IN K-12 SCHOOLS.....	71
DISCIPLINE INCIDENT FORM	70
ATTENDANCE AND SOCIAL WORK REFERRAL FORM.....	71
NOTICE REGARDING CODE OF STUDENT CONDUCT	73



THE SCHOOL BOARD OF GADSDEN COUNTY

35 Martin Luther King, Jr. Blvd
Quincy, Florida 32351
Main: (850) 627-9651 or Fax: (850) 627-2760
www.gadsdenschools.org

Elijah Key
Superintendent
keye@gcpsmail.com

SUPERINTENDENT'S MESSAGE

In order for the Gadsden County School District to perform effectively, it must operate within a system of rules. These rules are written in the Code of Student Conduct to ensure a safe learning environment for the students who attend our schools. We know that there are many factors that contribute to discipline problems in a school; consequently, schools have the responsibility to encourage, promote, and maintain effective disciplinary practices.

The contents of this document apply to all students in grades Pre-K -12, unless otherwise stated. The information contained in the Code of Student Conduct is written specifically to ensure that each student associated with school activities has positive experiences in a safe learning environment.

This document will explain the rules of the Gadsden County School District, student rights and student responsibilities, disciplinary actions, and the disposition of school records. While this document does not contain all the Florida Statutes referenced herein, a copy of those statutes can be obtained from the district office at 35 Martin Luther King, Jr. Boulevard in Quincy upon request or viewed on the State of Florida website at <http://www.leg.state.fl.us/statutes/>

The administrators and school personnel will continue to promote and maintain the kind of leadership that will foster a healthy dose of intervention, prevention, and the encouragement to discontinue those behaviors that are not acceptable to a safe learning environment. As we continue to find ways to make all of our schools safer, we realize that consequences for inappropriate behavior must be fair, consistent, and comply with policies as conflicts are resolved and undesirable behavior is modified.

Please read and thoroughly discuss this document with your child. Help us maintain the safe school status which we all desire throughout our district. We want to ensure that each student will have positive experiences in a safe, nurturing learning environment.

Respectfully yours,

Elijah Key

Superintendent of Schools

EK:jb

CATHY S. JOHNSON
DISTRICT NO. 1
HAVANA, FL 32333
MIDWAY, FL 32343

STEVE SCOTT
DISTRICT NO. 2
QUINCY, FL 32351
HAVANA, FL 32333

LEROY McMILLAN
DISTRICT NO. 3
CHATTAHOOCHEE, FL 32324
GREENSBORO, FL 32330

CHARLIE D. FROST
DISTRICT NO. 4
GRETNA, FL 32332
QUINCY, FL 32352

KAREMA D. DUDLEY
DISTRICT NO. 5
QUINCY, FL 32353

JURISDICTION OF THE SCHOOL BOARD

The Code of Student Conduct and the Positive Student Management Discipline Plan were adopted by the Gadsden County School Board and are compatible with the Florida State legislative codes. Subject to law and rules and regulations of the State Board of Education of the State of Florida, each student enrolled in a school shall, during the time he/she is being transported to or from school at public expense, during the time he/she is attending school, including the time during which he/she is proceeding from one school center to another during the school day, and during the time he/she is on the premises of any publicly supported school in this district, be under the control and direction of the principal or teacher in charge of the school, and under the immediate control and direction of the teacher or other member of the instructional staff or the bus driver to whom such responsibility may be assigned by the principal; and each such student shall, during the time he/she is otherwise en route to or from school at public expense, or is presumed by law to be attending school, be under the control and direction of the principal or teacher in charge of the school where he/she is enrolled.

DISCRIMINATION STATEMENT

No person shall, on the basis of race, color, religion, sex, national origin, handicap, age, or marital status, be excluded from participation in, be denied the benefits of, or be subjected to discrimination under, any education program or activity.

This practice shall apply equally to students, employees and all persons having business with the School Board.

PLEDGE OF ALLEGIANCE

The pledge of allegiance to the flag shall be recited at the beginning of the day in each public elementary, middle and high school in the Gadsden County School District. Upon written request by his or her parent, a student shall be excused from reciting the pledge, including standing and placing the right hand over his or her heart. When the pledge is given, unexcused students must show full respect to the flag by standing at attention, men removing headdress, except when such headdress is worn for religious purposes.

STUDENTS' RIGHTS AND RESPONSIBILITIES

It is the intent of the Students' Rights and Responsibilities, as expressed in the Code of Student Conduct that students understand that their rights must be accompanied by corresponding responsibilities.

Florida's School Improvement and Accountability System states that all school communities will provide an environment that is alcohol and drug-free and protects students' health, safety, and civil rights.

I. **ATTENDANCE (brick and mortar ~~or remote learning~~)**

All questions relating to the attendance policy are to be directed to the school's attendance office first, and then if needed, the school principal.

Florida law requires each parent/guardian of a child from age six (6) to sixteen (16) years to be responsible for the child's school attendance. Regular attendance is the actual attendance of a pupil during the school day as defined by law and regulations of the state board.

The school attendance law was amended by the 1997 Florida Legislature to require that any sixteen or seventeen year old student withdrawing from school must file a formal declaration of intent to terminate school enrollment with the district school board.

A student is considered "truant" when he/she is not in attendance without approval of the principal and/or consent of the parent/guardian. School-based interventions will occur for all truant students.

A student is considered a "habitual truant" when he/she has 15 unexcused absences within 90 calendar days.

DISTRICT ATTENDANCE GOAL 2023-2024 SCHOOL TERM

The educational program offered by this District is predicated upon the presence of the student and requires continuity of instruction and classroom participation. Attendance shall be required of all students enrolled in the schools during the days and hours that the school is in session. School attendance shall be the responsibility of parents and students. Absences shall be reported to the school attendance office by the parent or adult student as soon as practicable.

In accordance with statute, the Superintendent shall require, from the parent of each student of compulsory school age or from an adult student who has been absent from school or from class for any reason, a statement of the cause for such absence. The School Board reserves the right to verify such statements and to investigate the cause of each single absence.

In addition, educators shall have the responsibility of encouraging regular attendance of students, maintaining accurate attendance records, and following reporting procedures prescribed by the Superintendent.

Provision shall be made for promoting school attendance through adjustment of personal problems, education of parents, and enforcement of the compulsory attendance laws and related child-welfare legislation. Accordingly:

- A. ~~T~~eachers shall record absentees each period of the school day and report those absences;
- B. ~~P~~arents should be notified each time their child is absent insofar as possible;
- C. ~~W~~hen a student has been absent three (3) consecutive days and the school has been unable to ascertain the reason for the absences, the absences shall be investigated or at any other time if deemed necessary by the school principal.
- D. ~~A~~bsences must be reported to the school by the parent or adult student as soon as practicable. Failure to report and explain the absence(s) shall result in unexcused absence(s). The final authority for determining

acceptability of the reason for the absence(s) shall rest with the principal.

School-Based Intervention Procedures for Truant Students

The Board requires that the following school-based intervention procedures be adhered to for truant students:

- A. After three (3) days of unexcused absences, within a ninety (90) day period, a parent/guardian/student contact/conference is conducted by teacher/school designee.
- B. After five (5) days of unexcused absences, within a ninety (90) day period, a referral is made to the principal to send a certified letter to parents/guardians and possibly to convene a student study team. NOTE: Student study team is to convene when a student misses five (5) unexcused absences within thirty (30) calendar days, or when a student misses ten (10) days within ninety (90) calendar days.
- C. After ten (10) days of unexcused absences within a ninety (90) day period, the student is referred to the visiting teacher.
- D. After fifteen (15) unexcused absences within a ninety (90) day period, the student is considered "habitually truant," pursuant to [F.S. 1003.27\(b\)](#).

The Florida Legislature enacted requirements that school districts report to the Department of Highway Safety and Motor Vehicles (DHSMV) the names, birthdates, sex, and social security numbers of minors who attain the age of fourteen (14) and accumulate fifteen (15) unexcused absences in a period of ninety (90) calendar days. The legislation further provides that those minors under age eighteen (18) who thus fail to satisfy attendance requirements or drop out of (voluntarily withdraw from) school will be ineligible for driving privilege. Additional information about procedures and waivers is available from the school administration or guidance office.

Chronic truancy or deliberate nonattendance in excess of fifteen (15) school days within a semester shall be sufficient grounds for withdrawal of students sixteen (16) years of age or older, who are subject to compulsory school attendance under [F.S. 1003.21](#).

Excused Absence

If the absences are excused, all educational requirements for the course shall be met before a passing grade and/or credit is assigned. The student shall have a reasonable amount of time, up to ten (10) school days, to complete make-up work for excused absences. Principals may grant extensions to the make-up time limit for extenuating circumstances. Regarding make-up of the work missed as a result of unexcused absences, each principal shall establish site-specific policies that encourage both regular attendance and high academic achievement, and shall review and modify these policies from time-to-time as required to maintain and improve their effectiveness.

The Board considers the following factors to be reasonable excuses for time missed at school:

- A. Personal illness of the student (medical evidence may be required by the principal or designee for absences exceeding five (5) consecutive days).
- B. Court appearance of the student.
- C. Medical appointment of the student.
- D. An approved school activity (absences recorded but not reported).
- E. Insurmountable problems. Prior permission by principal or designee is required except in the case of an emergency.
- F. Other absences with prior approval of the Principal.
- G. Attendance at a center under Children and Families Services supervision.
- H. Significant community events with prior permission of the principal. When more than one (1) school is involved, the Area Superintendent will determine the status of the absence.

- I. Religious holiday (See Board Policy 3.18 and 5.40).
- J. Death in the immediate family.

Absences not included in excused absences listed above shall be unexcused.

Pursuant to State law, unexcused tardiness or absences shall not be grounds for suspension from school, but may result in other disciplinary consequences, such as detention or placement in existing alternative programs.

Any student who fails to attend any regularly scheduled class and has no excuse for absence should be referred to the appropriate administrator. Disciplinary action should include notification to parents or guardians.

The Superintendent shall develop administrative procedures that:

- A. Provide the student and his/her parents with the opportunity to challenge the attendance record prior to notification and that such notification complies with applicable Board rules;
- B. Govern the keeping of attendance records in accordance with the rules of the State Board;
- C. Identify the habitual truant, investigate the cause(s) of his/her behavior, and consider modification of his/her educational program to meet particular needs and interests;
- D. Require that students whose absence has been excused have an opportunity to make up work they missed and receive credit for the work, if completed;
- E. Require that any student, who, due to a specifically identifiable physical or mental impairment, exceeds or may exceed the District's limit on excused absence, is referred for evaluation for eligibility either under the Individuals with Disabilities Education Act (IDEA) or Section 504 of the Rehabilitation Act of 1973 or other appropriate accommodation.

Such regulations should provide that a student's grade in any course is based on his/her performance in the instructional setting and is not reduced for reasons of conduct. If a student violates the attendance or other rules of the school, s/he should be disciplined appropriately for the misconduct, but his/her grades should be based upon what the student can demonstrate s/he has learned.

Whenever any student has a total of fifteen (15) days of unexcused absence from school during any semester, s/he will be considered habitually absent. The Board authorizes the Superintendent to inform the student and his/her parents of the record of excessive absences as well as the District's intent to notify the Registrar of Motor Vehicles, if appropriate, and the Judge of the Juvenile Court of the student's excessive absences.

Students may not be given excused absences to remain out of school for the purpose of working, unless the job is an integral part of the student's instructional program.

F.S. [1002.20](#), [1003.21](#), [1003.24](#), [1003.26](#), [1003.27](#), [1006.09](#)

II. RESPECT FOR PERSONS AND PROPERTY

Rights:

Students are recognized as individuals. Their rights include a safe, healthy, and drug-free environment.

Responsibilities:

Students should treat others, school property, and property of others with respect. Respectful behavior includes, but is not limited to, following school, classroom, and bus rules. Unacceptable behavior includes, but is not limited to, fighting, stealing, destroying property, and violating school rules.

Rule:

Students will treat others and their property with dignity and respect.

Disciplinary Action:

A student not respecting the right and property of others may be subject to disciplinary action allowed by School Board policy. Disciplinary action may range from counseling to expulsion.

III. RIGHT TO LEARN

Rights:

Students have a right to be in an environment conducive to learning and will have appropriate educational programs.

Responsibilities:

Students should come to school prepared to take advantage of all educational opportunities offered. Students should inform school personnel if they have a problem at home or at school that keeps them from doing their best.

Rule:

Students will participate in educational opportunities and complete classroom assignments and homework to the best of their abilities.

Disciplinary Action:

Students who fail to comply with the above stated rule may hinder their educational progress and be subject to other disciplinary procedures allowed by the local school-wide discipline plan.

IV. RIGHT OF ASSEMBLY

Rights:

Students may meet in an orderly manner on the school grounds or building(s) if proper authorization has been granted.

Responsibilities:

The meetings must be approved by the principal/designee and must not interfere with other planned activities.

Rule:

With proper school authorization, students may assemble in an orderly manner.

Disciplinary Action:

Unauthorized or disorderly meetings will be terminated immediately by the principal/designee, and violators may be subject to further administrative disciplinary action.

V. RIGHT OF PRIVACY

Rights:

1. Only authorized persons may have access to student records as governed by Family Educational Rights and Privacy Act (FERPA) (20 U.S.C. §1232g. Regulations: 34 CFR Part 99.)
2. Students and their storage area, under the jurisdiction of the School Board, may be searched in cases of reasonable suspicion. Strip searching is prohibited. The use of metal detectors or specially trained animals is permissible.

Responsibilities:

1. Students, parents/guardians should give the school any information needed to work with the student.
2. Students should not bring prohibited items to school.

Rule:

Students will respect the privacy of others.

Disciplinary Action:

Prohibited items will be confiscated by school personnel and the students will be subject to disciplinary actions allowed by School Board policy.

VI. PARTICIPATION IN SCHOOL PROGRAMS AND ACTIVITIES

Rights:

All students will be a part of classroom instruction and other school activities for which they are qualified, without regards to their race, sex, religion, national origin, age, marital status, disability, or perceived disability.

Responsibilities:

Students should do their best in school or while participating in school activities. They should also be aware of the rights and responsibilities of others so as to make the school the best place of learning possible.

Rule:

Students who participate in or attend school activities will do so in a manner which promotes the objectives of the school and/or the activity.

Disciplinary Action:

Students who violate the above stated rule may be subject to disciplinary actions allowed by School Board policy.

VII. DRESS AND GROOMING

Disciplinary action resulting from a student's clothing or accessories must be determined pursuant to the school district's dress code unless the wearing of such clothing or accessories causes a substantial disruption of student learning, in which case the infraction may be addressed in a manner consistent with district school board policies for similar infractions.

Rights:

Students have a right to dress comfortably.

Responsibilities:

Students have a responsibility to wear clothes that are not dangerous to their health or safety and to dress in a manner that is not disrupting to the educational process. Clothes worn should not advertise drugs, gangs, alcohol, tobacco, inappropriate language and/or sexual behavior.

Rule:

Student will dress and groom in such a way as to express personal preferences within the guidelines of the school dress code. Students are prohibited from wearing bandannas, dropped pants, low riding jeans, and shorts revealing the buttocks or underwear, short tops revealing the belly button, and inappropriate short dresses, shorts, or skirts.

Elementary and Middle School Requirements:

Appropriate dress is the primary responsibility of the student and his/her parent or guardian. In order to promote safety, personal hygiene, academic well-being and moral and character development, students shall be expected to comply with reasonable requirements relating to dress, grooming and personal appearance as follows:

- 1) All students in elementary or middle school shall wear a school uniform while in attendance during the regular school day and on school sponsored field trips.
- 2) Colors shall be that of the official school colors and other colors as recommended by the School Advisory Committee and approved by the principal of the school.
- 3) Shirts/blouses must have a collar. T-shirts may be worn at the discretion of the individual school. Shirts must be tucked into pants.
- 4) Uniform style bottoms will be dark blue, black, tan (khaki). No sweat pants, overalls, or jeans will be allowed. Jeans are allowed to be worn at the discretion of the principal.
- 5) Uniform knee-length shorts/skirts will be acceptable.
- 6) Shoes must be safe and appropriate covering the student's feet.
- 7) Socks must be black, white, or other color as approved by the principal.
- 8) Boys and girls must wear belts if pants/shorts have belt loops. No sagging of pants will be allowed.
- 9) Outer garments for cold weather are permissible. Hooded sweatshirts are allowed but hoods may not be worn during school hours. Uniform shirt is required underneath.

A student who transfers from one school to another in the county will be required to wear the "generic school uniform", and will have 15 days to acquire the new school's uniform.

The "generic uniform" shall consist of the following:

- A. Khaki or black pants, shorts, or skirt
- B. White collared shirt
- C. Safe and appropriate shoes covering the feet.

At the beginning of the school year, students will be required to conform to the uniform dress code within but no later than the first ten (10) school days. Likewise, students transferring into the district will have the first fifteen (15) days of school enrollment in order to conform to the uniform dress code.

ALL STUDENTS (ELEMENTARY, MIDDLE AND HIGH) FOUND IN VIOLATION OF THE DRESS CODE WILL BE SUBJECTED TO THE FOLLOWING OPTIONS:

School Disciplinary Action:

Any student enrolled in an **Elementary, Middle and High School** who reports to school improperly attired shall be disciplined as follows:

- A. First and second offense consequences are:
 - a. Notification of parent or guardian and require student to change into appropriate attire
- B. Third offense consequences are:
 - a. Notification of parent or guardian, require student to change in to appropriate attire and **may receive counseling via School Counselor and/or School Social Worker**
 - b. One day of in-school suspension (if available) or three (3) days of after school detention.
- C. The fourth and subsequent offenses are considered to be willful disobedience that will result in further disciplinary action that may include additional days of in-school suspension, after school detention, or work detail.
- D. Students may also be removed from extracurricular activities by the Principal (**not to exceed 7 days/1 week/2 extracurricular activities**)

High School Disciplinary Action:

~~Any student enrolled in a high school who violates the dress code may receive counseling and/or parent/guardian(s) will be contacted.~~

Clothing and/or other personal adornment that is so unusual or non-traditional that it attracts undue attention and distracts from the academic climate of the classroom cannot be allowed.

APPROPRIATE ATTIRE

- When young ladies wear shorts, skirts, and dresses, the length must be near their knees. This knee length is determined by the indentation of the tip of the student's middle finger when placed against the student's attire.
- Bound sleeveless shirts and/or dresses that cover the armpits may be worn.
- Shirts/blouses must cover the midriff at all times.
- Young men must wear belts or suspenders with their pants. Elastic waist band/draw strings are acceptable.
- Hats and hoods may be worn outside of the building only.

INAPPROPRIATE ATTIRE

- Tight-fitting stretchy pants, leotards, bicycle pants, or body gloves
- Blouses or shirts that are unbuttoned, see-through, halter tops, tank tops, or muscle shirts and dresses that are strapless, spaghetti strap, or sun dresses,
- Section cutout garments with holes that are deemed inappropriate by administration
- Clothes that advertise gangs, alcoholic beverages, tobacco, drugs, suggestive or sexually explicit logos, or offensive racial slogans
- Headbands, bandannas, scarves, stocking/wave caps, or any other head gear
- Bare feet, bedroom slippers, flip-flops or beach shoes
- Hair combs, hair picks, or hair rollers
- Drop pants / saggy pants (F.S. 1006.07(2)(d) and F.S. 1006.15(4))
- Hooded sweatshirts are allowed, but hoods may not be worn during school hours. Must meet all clothing guidelines.

* **These** dress code guidelines are subject to the interpretation of the administration, faculty, and staff. Any other type of clothing or garment that is distracting, immodest, or interferes with learning will not be allowed.

VIII. WIRELESS COMMUNICATION DEVICES

The School Board is aware that wireless communication devices (WCDs) are used by students and parents to communicate with each other. However, the use of wireless communication devices (WCDs) on school grounds must be appropriately regulated to protect students, staff, and the learning environment. This policy sets forth the District's policy with respect to WCDs.

Students may possess wireless communication devices (WCDs) in school, on school property, during after school activities (e.g. extra-curricular activities) and at school-related functions, provided that during school hours and on school vehicles the WCDs are used for educational purposes for grades K-8 and at the discretion of the principal in grades 9-12.

A "wireless communication device" is a device that emits an audible signal, vibrates, displays a message, or otherwise summons or delivers a communication to the possessor. The following devices are examples of WCDs: cellular and wireless telephones, pagers/beepers, personal digital assistants (PDAs), Blackberries/Smartphones, Wi-Fi-enabled or broadband access devices, two-way radios or video broadcasting devices, laptops, and other devices that allow a person to record and/or transmit, on either a real time or delayed basis, sound, video or still images, text, or other information. Students may not use WCDs on school property or at a school-sponsored activity to access and/or view Internet web sites that are otherwise blocked to students at school.

Also, during after school activities when directed by the administrator or sponsor, WCDs shall be powered completely off (not just placed into vibrate or silent mode) and stored out of sight.

The requirement that WCDs must be powered completely off will not apply in the following circumstances when the student obtains prior approval from the building principal:

- A. The student is a member of a volunteer fire company/department, ambulance or rescue squad.
- B. The student has a special health circumstance (e.g. an ill family member, or his/her own special health condition).

The student is using the WCD for an educational or instructional purpose (e.g. taking notes, recording a class lecture, writing papers) with the teacher's permission and supervision. However, the use of any communication functionality of the WCD is expressly prohibited. This includes, but is not limited to, wireless Internet access, peer-to-peer (ad-hoc) networking, or any other method of communication with other devices or networks. In no circumstances shall the device be allowed to connect to the District's network. The preceding prohibitions do not apply to Board-owned and issued laptops, PDAs or authorized assistive technology devices.

Students are prohibited from using WCDs to capture, record or transmit the words (i.e. audio) and/or images (i.e., pictures/video) of any student, staff member or other person in the school or while attending a school-related activity, without express prior notice and explicit, written consent for the capture, recording or transmission of such words or images. Using a WCD to take or transmit audio and/or pictures/video of an individual without his/her consent is considered an invasion of privacy and is not permitted, unless authorized by the building principal. Students who violate this provision and/or use a WCD to violate the privacy rights of another person may have their WCD confiscated and held until the parent is contacted and picks up the device from the school.

"Sexting" is prohibited at any time on school property or at school functions. As set forth in State law, sexting is the knowing transmission or distribution to another minor by a computer or similar device any photograph or video of any person that depicts nudity and is harmful to minors. Sexting also includes possessing a photo of any person that was transmitted or distributed by another minor that depicts nudity. Such conduct not only is potentially dangerous for the involved students, but can lead to unwanted exposure of the messages and images to others, and could result in criminal violations related to the transmission or possession of child pornography. Such conduct will be subject to discipline and possible confiscation of the WCD.

The use of WCDs that contain built-in cameras (i.e. devices that take still or motion pictures, whether in a digital or other format) is prohibited in locker rooms and/or bathrooms and other areas where there is an expectation of privacy.

No expectation of confidentiality will exist in the use of WCDs on school premises/property.

Students are prohibited from using a WCD in any way that might reasonably create in the mind of another person an impression of being threatened, humiliated, harassed, embarrassed or intimidated. See Policy 5.321 – Bullying and Harassment. In particular, students are prohibited from using their WCDs to: (1) transmit material that is threatening, obscene, disruptive, or sexually explicit or that can be construed as harassment or disparagement of others based upon their race, national origin, sex, sexual orientation, age, disability, religion, or political beliefs; and (2) send, share, view or possess pictures, text messages, e-mails or other materials of a sexual nature (i.e., sexting) in electronic or any other form. As set forth in State law, sexting is the knowing transmission or distribution to another minor by a computer or similar device any photograph or video of any person that depicts nudity and is harmful to minors. Sexting also includes possessing a photo of any person that was transmitted or distributed by another minor that depicts nudity and is harmful to minors. Violation of these prohibitions shall result in disciplinary action. Furthermore, such actions will be reported to local law enforcement and child services as required by law.

Students are also prohibited from using a WCD to capture and/or transmit test information or any other information in a manner constituting fraud, theft, cheating, or academic dishonesty. Likewise, students are prohibited from using their WCDs to receive such information.

Possession of a WCD by a student is a privilege that may be forfeited by any student who fails to abide by the terms of this policy, or otherwise engages in misuse of this privilege.

Violations of this policy may result in disciplinary action and/or confiscation of the WCD. The building principal may also refer the matter to law enforcement if the violation involves an illegal activity (e.g. child pornography). Discipline will be imposed on an escalating scale ranging from a warning to an expulsion based on the number of previous violations and/or the nature of or circumstances surrounding a particular violation. If the WCD is confiscated, it will be released/returned to the student's parent/guardian after the student complies with any other disciplinary consequences that are imposed. In particular, egregious offenses involving the invasion of another person's privacy, the Board reserves the right to confiscate the WCD and hold it. A confiscated device will be marked in a removable manner with the student's name and held in a secure location in the building's central office until it is retrieved by the parent/guardian. WCDs in District custody will not be searched or otherwise tampered with unless school officials reasonably suspect that the search is required to discover evidence of a violation of the law or other school rules. Any search will be conducted in accordance with Policy 5.321 Search and Seizure. If multiple offenses occur, a student may lose his/her privilege to bring a WCD to school for a designated length of time or on a permanent basis.

A person who discovers a student in possession of or using a WCD in violation of this policy is required to report the violation to the building principal.

Students are personally and solely responsible for the care and security of their WCDs. The Board assumes no responsibility for theft, loss, damage, or vandalism to WCDs brought onto its property, or the unauthorized use of such devices.

Parents/Guardians are advised that the best way to get in touch with their child during the school day is by calling the school office.

Students may use school phones to contact parents/guardians. Students may use their WCDs after the school day has ended.

[F.S. 847.0141](#), [1006.07\(2\)](#)

IX. DISCRIMINATION/SEXUAL HARASSMENT

Rights:

Students have the right to attend school and learn in an environment free from discrimination and sexual harassment.

Responsibilities:

Students should report occurrences of discrimination or sexual harassment to the principal through the proper grievance procedures.

Rules:

No student shall on the basis of race, sex, religion, national origin, age, marital status, disability, or perceived disability, be excluded from participation in, be denied the benefits of, or be subjected to discrimination/sexual harassment under any educational program or activity.

Disciplinary Actions:

Students who violate the above-stated rule may be subject to disciplinary actions allowed by School Board policy.

X. COUNSELING

Rights:

Students have the right:

1. To be informed as to the nature of the guidance services available in their school.
2. To have access to individual and group counseling.
3. To request a change of counselor as applicable.
4. Students have the right of confidentiality except in the following circumstances:
 - a. Reports of abuse or neglect,
 - b. Indication of harm to self/others.

Responsibilities:

Students have the responsibilities:

1. To use guidance services for their own educational and personal improvement.
2. To schedule appointments in advance unless the problem or concern is one of an emergency.
3. To work cooperatively with all school personnel.

Rule:

Students should participate appropriately in the counseling process.

Disciplinary Action:

Students who fail to participate appropriately in the counseling process may temporarily have their opportunities for counseling suspended, or other disciplinary measures may be taken.

XI. FREE SPEECH AND PUBLICATION

Rights:

1. Students will be given the opportunity to participate freely in class discussions.
2. Students may, with the approval of the principal/designee, write and distribute non-commercial printed materials. This shall include freedom of the press for all student publications.
3. Students may decide whether or not to participate in symbolic (e.g. flag salute) or religious activities.
4. After receiving permission from the principal, students may display posters, notices, magazines, or articles.
5. Students participation in classroom instruction or other school activities may not be denied based on race, sex, religion, national origin, age, marital status, exceptionality, or perceived disability.

Responsibilities:

1. Students must use appropriate language when expressing their thoughts, concerns, and opinions.
2. Students must respect the principal's decision concerning the request to display printed material.
3. Students should respect others' rights, responsibilities, and opinions.

Rule:

The principal/designee will ensure that all printed materials distributed in the school reflect appropriate journalistic ethics and are not obscene or offensive by school and community standards.

Disciplinary Action:

The principal may discipline any student for infraction of the above stated rule.

XII. STUDENT GOVERNMENT

Rights:

Students have the following rights:

1. To form and operate a student government at their respective schools under the direction of a faculty advisor.
2. To have access to policies of the School Board and the individual school.
3. To seek office in student government, or any school organization, regardless of race, sex, religion, national origin, age, marital status, disability, or perceived disability.
4. To attend, as student government officers and representatives, official student government meetings upon approval of such meetings by the school principal.

Responsibilities:

Students have the following responsibilities:

1. To elect student government officers and representatives who are responsive to the needs of the school and who will work constructively toward the resolution of such needs.

2. To become knowledgeable of School Board and individual school policies governing the actions of students.
3. To conduct election campaigns in a positive, mature manner, with all due respect provided their opponents.
4. To attend regularly scheduled meetings, if an elected student representative, and exhibit appropriate conduct at all times.

Rule:

Students will use the democratic process to conduct student government operations.

Disciplinary Action:

The principal/designee may apply disciplinary procedures as appropriate.

XIII. STUDENT RECORDS

Rights:

Students/Parents/guardians have the following rights:

1. Information contained in records that relates directly to the student may be inspected, reviewed, and challenged.
2. Personal identifiable information will be protected by legal provisions which prohibit its release to any person who is not legally authorized by the consent of the parent, guardian, or eligible student. (An eligible student is one who is 18 years of age or over and/or one who attends a post-secondary institution.)
3. Parents/guardians will receive annual notification, written in their native language, stating that they may review their child's record.

Rules/Procedures Relating to Student Records:

Student Records: The principal of each school shall be responsible for all student records and will ensure that all state and federal rules are followed. The Superintendent will make all rules available to principals.

- I. Purposes. Rules cover all school records of all students.
- II. Definitions:
 - A. Education Records: Records required by law containing information about the student
 1. Category A - Permanent Information: student information that is required by law to be kept indefinitely.
 2. Category B - Temporary Information: student information that may be kept for a short time then discarded or changed
 - B. Child: a person who is under 18 years of age
 - C. Pupil/Student: a person who is enrolled in a school
 - D. Eligible Student: a person who is 18 years old or older and who is enrolled in one or more offered educational programs by the Gadsden County district (see section IV.)

- III. The Cumulative Record: The principal is responsible for all cumulative records. These records must be kept at school and may be relocated to other schools upon appropriate written request.
- A. Content of Category A Records: Category A records contain the permanent report card and education records. These records are kept up to date and cannot be changed without the permission of the principal. The person making the change will initialize each change.
1. Student's birth certificate name
 2. Birth date, place of birth, race, and sex
 3. Current address of the student
 4. Name of parent(s) or guardian(s)
 5. Name of last school attended
 6. Number of days present, absent
 7. Date enrolled, date withdrawn
 8. Classes/subjects taken, grades received
 9. Date of graduation or program completion
- B. Content of Category B Records:
1. Health information
 2. Information about the student's family
 3. Test scores
 4. School and vocational plans
 5. Honors and school activities
 6. Reports of special classes required by law
 7. List of schools attended
 8. Driver education certificate
 9. Letters from other groups
 10. Written requests for permission to review the record
 11. List of people who requested and received a copy of the record
 12. Written information indicating any changes made in the record
 13. Summary of state student assessment test results
 14. Copies of exceptional student education placement reports as required by law.
 15. Records of discipline, suspension, and expulsion
 16. Records of counselors' and teachers' conferences with students
 17. Free lunch applications, work experience interviews, and other records
- IV. The following strategies may be used for an eligible student or parent/guardian to change or remove a portion of the student record:
- A. A written request must be submitted to the principal, clearly identifying the part of the record to be changed, and specifying why it is inaccurate or misleading.
- B. If the request is approved, the change or removal shall be made in writing and signed and dated by the eligible student or parent/guardian and a school official. The written agreement shall show only that the record has been corrected or a portion removed.
- C. If the District denies the request for the change of record, the District will notify the eligible student or parent/guardian of the decision, advising them of their right to a hearing. Information regarding the hearing procedures will be provided to the eligible student or parent/guardian.
- D. If a hearing is held and a decision is made to keep the record intact without the proposed change, the eligible student or parent/guardian may include a written statement in the

record. The statement may indicate disagreement with the decision and state reasons for disagreement.

V. Procedures for Transfer of Education Records.

- A. Records shall be transferred immediately upon written request from an eligible student or parent/guardian or from a school to which a student has transferred. The principal or designee shall transfer all Category A and Category B information and shall keep a copy of Category A information.
- B. Records shall not be prohibited from transfer for unpaid fees or fines assessed by the school.
- C. For all Gadsden County schools, current records shall be passed to a middle or high school upon student promotion to that school. This transfer will occur automatically without request.
- D. If a school is closed by order of the School Board, student records shall be transferred to the school at which students will attend the following year. If students will not attend school the following year, the Superintendent shall decide where records will be kept.

Notification of Rights for Elementary and Secondary Schools

FERPA affords parents/guardians and students over 18 years of age (“eligible students”) certain rights with respect to the student’s educational records. These rights are:

- 1. The right to inspect and review the student’s education records within 45 days of the day the School receives a request for access. Parents/guardians or eligible students should submit to the School principal (or appropriate school official) a written request that identifies the record(s) they wish to inspect. The School official will make arrangements for access and notify the parent/guardian or eligible student of the time and place where the records may be inspected.
- 2. The right to request the amendment of the student’s education records that the parent/guardian or eligible student believes are inaccurate or misleading. Parents/guardians or eligible students may ask the School to amend a record that they believe is inaccurate or misleading. They should write the School principal (or appropriate official), clearly identify the part of the record they want changed, and specify why it is inaccurate or misleading. If the School decides not to amend the record as requested by the parent/guardian or eligible student, the School will notify the parent/guardian or eligible student of the decision and advise them of their right to a hearing regarding the request for amendment. Additional information regarding the hearing procedures will be provided to the parent/guardian or eligible student when notified of the right to a hearing.
- 3. The right to consent to disclosures of personally identifiable information contained in the student’s education records, except to the extent that FERPA authorizes disclosure without consent. One exception, which permits disclosure without consent, is disclosure to school officials with legitimate educational interests. A school official is a person employed by the School as an administrator, supervisor, instructor, or support staff member (including health or medical staff and law enforcement unit personnel); a person serving on the School Board; a person or company with whom the School has contracted to perform a special task (such as an attorney, auditor, medical consultant, or therapist); or a parent/guardian or student serving on an official committee, such as a disciplinary or grievance committee, or assisting another school official in performing his or her tasks. A school official has a legitimate educational interest if the official needs to review an education record in order to fulfill his or her professional responsibility. (Optional) Upon request, the School discloses educational records without consent to officials of another school district in which a student seeks or intends to enroll.

Parents/guardians have the following rights:

- a. They may review their child's school records.
 - b. They may give permission for others to review the records.
 - c. They may challenge information in the records.
 - d. Upon request they will receive a copy of this rule from the Superintendent's office.
4. Eligible students or parents/guardians of the student may review individual records. Copies of records may be obtained through written request to the principal or School Board contact person. All requests will be granted within 5 working days.
 5. An eligible student or parent/guardian may give permission for others to review letters or statements in the student's records. Permission must be in writing and signed by the eligible student or parent/guardian. Access by others to a student's record will be closed upon written request by the eligible student or parent/guardian.
 6. The fee for copying the school records shall be as provided by School Board Policy.
 7. Student records are located at the school/district office.
 8. Records that give personal information may not be released without an appropriate request, except to the following:
 - a. District and school administrators and supervisors
 - b. District and school personnel, their interns, and substitutes
 - c. Administrative secretaries (as required for record keeping duties)
 - d. Gadsden County Health Department (health records only)
 - e. Florida Diagnostic and Learning Resource System personnel
 - f. Officials from a school to which a student has moved
 - g. State and federal officers, if records are needed to meet legal requirements, including Judicial and law enforcement agencies as specified within signed interagency agreements.
 - h. Persons requiring information for the purpose of donating money for tuition and other related expenses
 - i. State and local people who collect data for factual reporting
 - j. Colleges/Universities needing information for the benefit of students
 - k. People who set standards for schools
 - l. Parents/guardians for tax reasons
 - m. To comply with a court order
 - n. Any person requiring information for health or safety emergencies
 - o. Persons needing information for student expulsion hearings
 - p. Educational researchers who will not publish personal identification, and who destroy the information at the end of the study
 9. Parents/guardians eligible students have the right to file complaints with the U.S. Department of Education concerning alleged failures by the District to comply with the requirements of the Family Educational Rights and Privacy Act (FERPA). Inquiries may be addressed to: Family Policy Compliance Office, U.S. Department of Education, 400 Maryland Avenue, SW, Washington, DC 20202-4605

Responsibilities:

Students/Parents/guardians have the following responsibilities:

1. To inform the school of any information that may be useful in making appropriate educational decisions.
2. To authorize release of pertinent information to those individuals or agencies who are working actively and constructively for the benefit of the student.

Rule:

Students and parents/guardians must comply with board policies related to student records.

Disciplinary Action:

Failure of students/parents/guardians to provide accurate information may result in inaccurate maintenance of student records and a delay in delivery of services in a timely manner. For additional information regarding student records, and procedures, see Appendix.

XIV. GRADES

Rights:

Students have the following rights:

1. To receive a teacher's grading criteria at the beginning of each year or semester course.
2. To receive reasonable notification of failure or potential failure at any time during the grading period when it is apparent unsatisfactory work is being performed.
3. To receive periodic academic reports which may include, but not be limited to, academic and/or conduct grades. A conduct grade may not affect an academic grade.

Responsibilities:

Students have the following responsibilities:

1. To become informed of the grading criteria and behavior standards.
2. To maintain standards of academic performance commensurate with ability.

Rules:

Students enrolled in the Gadsden County School District will comply with the provisions of the Student Progression Plan.

GENERAL DISCIPLINARY PROCEDURES

Students are under the authority of the principal/designee, teacher, or bus driver any time they are going to or from school, at school, or at any school activity. Law enforcement or other appropriate agencies may be notified by the principal/designee as deemed necessary. Law enforcement must be notified for battery, homicide, kidnapping and sexual battery.

I. PRESENCE OF PUPILS, WHEN AND WHERE AUTHORIZED

Students have permission to be on the school grounds during the regular school day and during special activities. The principal will use appropriate disciplinary procedures with any student who is found on campus without permission.

II. AUTHORITY OF THE TEACHER

- A. The teacher has the authority to control students while on school campus or at any school event.

- B. Florida Statutes [F.S. 1003.32 \(4\)](#) authorizes the teacher to remove from class, students with abusive, disruptive, or unruly behavior. According to the statute, a teacher may remove from class a student whose behavior the teacher determines interferes with the teacher's ability to communicate effectively with the students in the class or with the ability of the student's classmates to learn. Each district school board, each district school superintendent, and each school principal shall support the authority of teachers to remove disobedient, violent, abusive, uncontrollable, or disruptive students from the classroom. **(Refer to F.S. 1003.32 for more details.)**

III. OFFENSES

- A. Students shall not be subject to discipline which is verbally abusive, severe, or humiliating. Discipline shall not consist of the denial of breakfast, lunch, or toileting.
- B. The principal may discipline any student for, including but not limited to, the following misbehaviors:
1. disobeying or threatening any school personnel
 2. profanity; offensive gestures
 3. destroying property
 4. disturbing school functions ([FS 1006.145](#))
 5. leaving school without proper permission
 6. excessive tardies and/or unexcused absences from school
 7. breaking school rules
 8. serious misconduct
 9. sexual harassment
 10. multiple offenses
 11. fighting (to include instigating a fight)
 12. usage of wireless communication devices and all other electronic devices (such as pagers, cellular phones, iPods, MP3 players)
 13. possession of weapons and/or any firearm, to include imitation firearm
 14. possession or use of alcohol, tobacco, or other drugs
- C. Serious misconduct or multiple offenses may result in expulsion of the student by the School Board.
- D. When a non-English-proficient student and/or parent/guardian(s) are involved in any disciplinary procedure, an interpreter will participate in the process.
- E. When a student is guilty of any act or threat of violence to any school personnel on campus or at a school activity, the principal may discipline the student by suspension and/or request that the School Board expel the student.
- F. School personnel should use the disciplinary method commensurate with the offense. The discipline will be fair and will be given to each student on an individual basis. Before the student is disciplined, the student has the right to tell his/her side of the story and he/she should be told why he/she is receiving the punishment.

- G. If a student is to be suspended, he/she will be told why before being suspended and will also get an explanation of the evidence and a chance to tell his/her side. Every effort will be made to notify the parent/guardian(s) as soon as possible. A principal may suspend for five days. If the suspension is for more than five days, or if the student is recommended for expulsion, a hearing will be held. If the student is a danger to other students or constantly keeps others from learning, he/she may be immediately removed from class and/or school. Only the School Board can expel a student. (See VIII A-B.) When a student is suspended, privileges to participate in extra-curricular activities will be revoked.
- H. All disciplinary referrals will be maintained in the district's student database.

IV. DEFERRED PUNISHMENT FOR OFFENSES

Disciplinary action for offenses occurring near the end of the school year may be carried over to the next school term.

BULLYING AND HARASSMENT – Gadsden School Board Policy #5.321

B. Expulsion

1. Dismissal of a student with a disability shall follow the procedures contained in School Board Policy.
2. Prior to making a recommendation for expulsion to the Superintendent or (his/her designee), the principal (or his/her designee) shall notify the Director of Exceptional Student Education (or designee) in writing that this action is being considered.
3. The principal, or his/her designee, shall meet with the school staffing committee and the Director of Exceptional Student Education (or designee) to determine if the student's actions are a result of his/her disabling condition (Manifestation Determination). The staffing committee will be comprised of the following personnel: Director of Exceptional Student Education or designee, School Administrator, ESE teacher, general education teacher(s), parents, school counselor, and any other appropriate individuals.
4. If the staffing committee determines that the student's actions are not a result of his/her disabling condition, the principal, or his/her designee, may submit a recommendation for alternative placement or expulsion to the Superintendent, or his/her designee. This recommendation shall contain the school staffing committee report, the Functional Behavior Assessment (FBA), Behavior Intervention Plan (BIP), and the student's Individual Educational Plan (IEP). A copy of this recommendation shall be sent to the Director of Exceptional Student Education.
5. If the staffing committee determines the student's conduct is a manifestation of his/her disability, then an IEP meeting must be held to determine the adequacy of the current special program and related services.
6. Prior to any Change of Placement, the Individual Educational Plan Procedures, as outlined in *Gadsden County Special Programs and Procedures for Exceptional Students*, will be followed to ensure that parents/guardians are provided safe-guards consistent with State Board of Education Rule 6A-6.03311.
7. Any change in the educational placement of a student with a disability will not result in a cessation of education services.

(F.S. 1006.147)

The Gadsden County School Board prohibits acts of bullying and harassment. The School Board has determined that a safe and civil environment in school is necessary for students to learn and achieve high academic standards. Bullying or harassment, like other disruptive or violent behaviors, is conduct that disrupts both a student's ability to learn and a school's ability to educate its students in a safe environment. Demonstration of appropriate behavior, treating others with civility and respect, and refusing to tolerate bullying or harassment is expected of administrators, faculty, staff, and volunteers to provide positive examples for student behavior.

Bullying includes cyberbullying and means systematically and chronically inflicting physical hurt or psychological distress on one or more students or school employees.

Bullying or harassment is any gesture or written, verbal, graphic, or physical act (including electronically transmitted acts – i.e. internet, cell phone, or wireless handheld device) that is reasonably perceived as being motivated either by any actual or perceived characteristic, such as race, color, religion, ancestry, national origin, gender, sexual orientation, gender identity and expression; or a mental, physical, or sensory disability or impairment; or by any other distinguishing characteristic. Such behavior is considered harassment or bullying whether it takes place on or off school property, at any school-sponsored function, or in a school vehicle.

1. Statement Prohibiting Bullying and Harassment

- A. It is the policy of the Gadsden County School District that all of its students and school employees have an educational setting that is safe, secure and free from harassment and bullying. The District will not tolerate bullying and harassment of any kind. Conduct that constitutes bullying and harassment, as defined herein, is prohibited.
- B. The District upholds that bullying or harassment of any student or school employee is prohibited:
 - 1. During any education program or activity conducted by a public K- 12 educational institution;
 - 2. During any school-related or school-sponsored program or activity;
 - 3. On a school bus of a public K-12 educational institution; or
 - 4. Through the use of data or computer software that is accessed through a computer, computer system, or computer network of a public K- 12 education institution.

2. Definitions

- A. **Bullying** means systematically and chronically inflicting physical hurt or psychological distress on one or more students, or employees. It is further defined as unwanted and repeated written, verbal, or physical behavior, including any threatening, insulting, or dehumanizing gesture, by a student or adult, that is severe or pervasive enough to create an intimidating, hostile, or offensive educational environment; cause discomfort or humiliation; or unreasonably interfere with the individual's school performance or participation; and may involve but is not limited to:
 - 1. Unwanted teasing;
 - 2. Social Exclusion;
 - 3. Threatening;
 - 4. Intimidation;
 - 5. Stalking;
 - 6. Cyberstalking;
 - 7. Cyberbullying;
 - 8. Physical violence;
 - 9. Theft;
 - 10. Sexual, religious, or racial harassment;
 - 11. Public humiliation;
 - 12. Rumor or spreading falsehoods; or
 - 13. Destruction of school or personal property.
 - 14. Private humiliation
- B. **Harassment** means any threatening, insulting or dehumanizing gesture, use of technology, computer software, or written, verbal or physical conduct directed against a student or school employee that:
 - 1. Places a student or school employee in reasonable fear of harm to his/her person or damage to his/her property;
 - 2. Has the effect of substantially interfering with a student's educational performance, or employee's work performance, or either's opportunities, or benefits;
 - 3. Has the effect of substantially negatively impacting a student's or employee's emotional or mental well-being; or
 - 4. Has the effect of substantially disrupting the orderly operation of a school.
- C. **Cyberstalking** is defined in [F.S. 784.048\(d\)](#) means to engage in a course of conduct to communicate, or to cause to be communicated, words, images, or language by or through the use

of electronic mail or electronic communication, directed at or about a specific person, causing substantial emotional distress to that person and serving no legitimate purpose.

- D. **Cyberbullying** means bullying through the use of technology or any electronic communication, which includes, but is not limited to, any transfer of signs, signals, writing, images, sounds, data, or intelligence of any nature transmitted in whole or in part by a wire, radio, electromagnetic system, photoelectronic system, or photo optical system, including, but not limited to, electronic mail, Internet communications, instant messages, or facsimile communications. Cyberbullying includes the creation of a webpage or weblog in which the creator assumes the identity of another person, or the knowing impersonation of another person as the author of posted content or messages, if the creation or impersonation creates any of the conditions enumerated in the definition of bullying. Cyberbullying also includes the distribution by electronic means of a communication to more than one person or the posting of material on an electronic medium that may be accessed by one or more persons, if the distribution or posting creates any of the conditions enumerated in the definition of bullying.
- E. **Bullying, Harassment, and/or Cyberbullying** also encompass:
1. Retaliation against a student or school employee by another student or school employee for asserting or alleging an act of bullying or harassment. Reporting an act of bullying or harassment that is not made in good faith is considered retaliation.
 2. Perpetuation of conduct listed in the definition of bullying or harassment by an individual or group with intent to demean, dehumanize, embarrass, or cause emotional or physical harm to a student or school employee by
 - a. Incitement or coercion;
 - b. Accessing or knowingly and willingly causing or providing access to data or computer software through a computer, computer system, or computer network within the scope of the District school system;
 - c. Acting in a manner that has an effect substantially similar to the effect of bullying or harassment.
 3. Unwanted harm towards a student or employee in regard to their real or perceived: sex, race, color, religion, national origin, age, disability (physical, mental, or educational), marital status, socio-economic background, ancestry, ethnicity, gender, gender identity or expression, linguistic preference, political beliefs, sexual orientation, or social/family background or being viewed as different in its education programs or admissions to education programs and therefore prohibits bullying of any student or employee by any Board member, District employee, consultant, contractor, agent, visitor, volunteer, student, or other person in the school or outside the school at school-sponsored events, on school buses, and at training facilities or training programs sponsored by the District. For Federal requirements when these acts are against Federally identified protected categories, refer to Board Policy 2.70 [\(F.S. 1000.05\(2\)\(a\)\)](#)
- F. **Accused** is defined as any District employee, consultant, contractor, agent, visitor, volunteer, student, or other person in the school or outside the school at school-sponsored events, on school buses, and at training facilities or training programs sponsored by the District who is reported to have committed an act of bullying, whether formally or informally, verbally or in writing, of bullying.
- G. **Complainant** is defined as any District employee, consultant, contractor, agent, visitor, volunteer, student, or other
3. Behavior Standards
- A. The Gadsden County School District expects students and adults to conduct themselves as appropriate for their levels of development, maturity, and demonstrated capabilities with proper regard to the rights and welfare of other students and school staff, the educational purpose underlying all school activities, and the care of school facilities and equipment.

- B. The District believes that standards for student behavior must be set cooperatively through interaction among the students, parents/legal guardians, staff, and community members producing an atmosphere that encourages students to grow in self-discipline. The development of this atmosphere requires respect for self and others, as well as for District and community property on the part of students, staff, and community members. Because students learn by example, school administrators, faculty, staff, and volunteers will demonstrate appropriate behavior, treat others with civility and respect, and refuse to tolerate bullying or harassment.
 - C. The School District prohibits the bullying of any student or school employee:
 - a. During any educational program or activity conducted by Gadsden County Schools District;
 - b. during any school-related or school-sponsored program or activity or on a Gadsden County school bus;
 - c. Through the use of any electronic device or data while on school grounds or on a Gadsden County school bus, computer software that is accessed through a computer, computer system, or computer network of the Gadsden County School Board. The physical location or time of access of a computer-related incident cannot be raised as a defense in any disciplinary action initiated under this section.
 - d. Through threats using the above to be carried out on school grounds. This includes threats made outside of school hours, which are intended to be carried out during any school-related or school-sponsored program or activity, or on a Gadsden County school bus.
 - e. While the District does not assume any liability for incidences that occur at a bus stop or in route to and from school, a student or witness may file a complaint following the same procedures for bullying against a student and the school will investigate and/or provide assistance and intervention as the principal/designee deems appropriate, which may include the use of the School Resource Officer. The principal/designee shall use all District Reporting Systems to log all reports and interventions.
 - D. All administrators, faculty, and staff, in collaboration with parents, students, and community members, will incorporate systemic methods for student and staff recognition through positive reinforcement for good conduct, self-discipline, good citizenship, and academic success, as seen in the required school plan to address positive school culture and behavior (the school's Discipline Plan).
 - E. Student rights shall be explained as outlined in this policy and in the Code of Student Conduct: Respect for Persons and Property.
 - F. Proper prevention and intervention steps shall be taken based on the level of severity of infraction as outlined in the Code of Student Conduct and this Policy.
4. Stakeholder Responsibilities
- A. By August 2009, each school principal shall create a School Safety team and designate one of its members as a School Safety Liaison and contact who shall serve on a district School Safety team that address acts of violence and school safety. The district's Safety Investigation's Officer will be head the School Safety Team. At minimum, school teams should include staff members from administration, guidance, and instruction. These persons will serve as the key school based personnel who will receive prevention/safety training and assist in the dissemination of prevention/safety procedures, intervention, and curriculum, for bullying and other issues that impact the school culture and welfare of students and staff.
 - B. The Academic Services' Office, in collaboration with other District departments, will collaborate with school based staff members, families, and community stakeholders to utilize this Policy and associated procedures to promote academic success, enhance resiliency, build developmental assets, and promote protective factors within each school by ensuring that each and every staff member and student is trained on violence prevention. These trainings will work to create a climate within each school and within the District that fosters the safety and respect of children and the belief that adults are there to protect and help them. Additionally, students and staff

(including but not limited to school based employees, administrators, district personnel, counseling staff, and bus drivers) will be given the skills, training, and tools needed to create the foundation for preventing, identifying, investigating, and intervening when issues of bullying arise.

- C. The Family and Community Engagement Office, in collaboration with other District departments, will train a wide range of community stakeholders, profit, non-profit, School Resource Officers, and faith based agencies to provide the dissemination and support of violence prevention curriculums to students, their families and school staff. This collaboration will make effective use of available school district and community resources while ensuring seamless service delivery in which each and every school and student receives an equitable foundation of violence prevention.
- D. The District School Safety Team will serve as the coordinators and trainers of prevention/safety for all school staff and outside agencies/community partners. The District Safety Team will receive training in violence prevention programs. These team will ensure that these programs are evidence-based and proven. The team will be responsible for implementing the evidence-based interventions and proven programs within each of their schools.
- E. The Family and Community Engagement Office, in collaboration with other District departments, will provide opportunities and encourage parents to participate in prevention efforts with their children in meaningful and relevant ways that address the academic, social, and health needs of their children. The District will offer parents and parent associations' trainings on violence prevention as well as knowledge of and/or opportunity to participate in any violence prevention initiatives currently taking place in their school via the district and school websites, open houses, and school newsletters. Training will provide resources and support for parents by linking them with internal supports as well as referral to community-based resources as needed.
- F. Evaluations to determine the effectiveness and efficiency of the services being provided will be conducted at least every three years and shall include data-based outcomes.
- G. The Superintendent, other district administrators, as well as school principals, will be held accountable for implementation of these student support services consistent with the standards of this policy. These administrators will take steps to assure that student support services are fully integrated with their instructional components at each school as well as in policy and practice.

V. Training for all Stakeholders

- At the beginning of each school year, the school principal/designee and or appropriate area/district administrator shall provide awareness of this policy, as well as the process for reporting incidents, investigation and appeal, to students, school staff, parents, or other persons responsible for the welfare of a pupil through appropriate references in the Code of Student Conduct, Employee Handbooks, the school website, and/or through other reasonable means.

VI. Consequences

- A. Committing an act of bullying or harassment
 1. Concluding whether a particular action or incident constitutes a violation of this policy requires a determination based on all of the facts and surrounding circumstances. The physical location or time of access of a computer-related incident cannot be raised as a defense in any disciplinary action.
 2. Consequences and appropriate remedial action for students who commit acts of bullying or harassment may range from positive behavioral interventions up to and including suspension or expulsion, as outlined in the Code of Student Conduct.
 3. Consequences and appropriate remedial action for a school employee, found to have committed an act of bullying or harassment, shall be determined in accordance with District policies, procedures, and agreements. Additionally, gross acts of harassment by certified educators may result in a sanction against an educator's state issued certificate.

4. Consequences and appropriate remedial action for a visitor or volunteer, found to have committed an act of bullying or harassment, shall be determined by the school administrator after consideration of the nature and circumstances of the act, including reports to appropriate law enforcement officials.
- B. Wrongful and intentional accusation of an act of bullying or harassment
1. Consequences and appropriate remedial action for a student, found to have wrongfully and intentionally accused another as a means of bullying or harassment, range from positive behavioral interventions up to and including suspension or expulsion, as outlined in the Code of Student Conduct.
 2. Consequences and appropriate remedial action for a school employee, found to have wrongfully and intentionally accused another as a means of bullying or harassment, shall be determined in accordance with District policies, procedures, and agreements.
 3. Consequences and appropriate remedial action for a visitor or volunteer, found to have wrongfully and intentionally accused another as a means of bullying or harassment shall be determined by the school administrator after consideration of the nature and circumstances of the act, including reports to appropriate law enforcement officials.
- C. Receiving Reports of Acts of Bullying or Harassment
1. At each school, the principal or the principal's designee shall be responsible for receiving complaints alleging violations of this policy.
 2. All school employees are required to report alleged violations of this policy to the principal or the principal's designee.
 3. All other members of the school community, including students, parents/legal guardians, volunteers, and visitors are encouraged to report any act that may be a violation of this policy anonymously or in person to the principal or principal's designee.
 4. The principal of each school in the District shall establish and prominently publicize to students, staff, volunteers, and parents/legal guardians, how a report of bullying or harassment may be filed either in person or anonymously and how this report will be acted upon.
 5. The victim of bullying or harassment, anyone who witnessed the bullying or harassment, and anyone who has credible information that an act of bullying or harassment has taken place may file a report of bullying or harassment.
 6. A school employee, school volunteer, student, parent/legal guardian or other persons who promptly reports in good faith an act of bullying or harassment to the appropriate school official and who makes this report in compliance with the procedures set forth in the District policy is immune from a cause of action for damages arising out of the reporting itself or any failure to remedy the reported incident.
 7. Submission of a good faith complaint or report of bullying or harassment will not affect the complainant or reporter's future employment, grades, learning or working environment, or work assignments.
 8. Any written or oral reporting of an act of bullying or harassment shall be considered an official means of reporting such act(s).
 9. Reports may be made anonymously, but formal disciplinary action may not be based solely on the basis of an anonymous report.
- D. Investigation of a Report of Bullying or Harassment
1. The investigation of a reported act of bullying or harassment is deemed to be a school-related activity and begins with a report of such an act. Incidents that require a reasonable investigation when reported to appropriate school authorities shall include alleged incidents of bullying or harassment allegedly committed against a child while the child is in route to school aboard a school bus or at a school bus stop.
 2. The principal or designee shall select an individual(s), employed by the school and trained in investigative procedures, to initiate the investigation. The person may not be the accused perpetrator (harasser or bully) or victim.
 3. Documented interviews of the victim, alleged perpetrator, and witnesses shall be conducted privately, separately, and shall be confidential. Each individual (victim, alleged perpetrator, and

witnesses) will be interviewed separately and at no time will the alleged perpetrator and victim be interviewed together.

4. The investigator shall collect and evaluate the facts including but not limited to:
 - i. Description of incident(s) including nature of the behavior;
 - ii. Context in which the alleged incident(s) occurred;
 - iii. How often the conduct occurred;
 - iv. Whether there were past incidents or past continuing patterns of behavior;
 - v. The relationship between the parties involved;
 - vi. The characteristics of parties involved, *i.e.*, grade, age;
 - vii. The identity and number of individuals who participated in bullying or harassing behavior;
 - viii. Where the alleged incident(s) occurred;
 - ix. Whether the conduct adversely affected the student's education, educational environment or mental well-being;
 - x. Whether the alleged victim felt or perceived an imbalance of power as a result of the reported incident; and
 - xi. The date, time, and method in which the parents/legal guardians of all parties involved were contacted.
 5. Whether a particular action or incident constitutes a violation of this policy shall require a determination based on all the facts and surrounding circumstances and shall include but not limited to:
 - i. Recommended remedial steps necessary to stop the bullying and/or harassing behavior; and
 - ii. A written final report to the principal.
 6. The maximum of ten (10) school days shall be the limit for the initial filing of incidents and completion of the investigative procedural steps.
 7. The highest level of confidentiality possible will be upheld regarding the submission of a complaint or a report of bullying and/or harassment and the investigative procedures that follow.
- E. Investigation to Determine Whether a Reported Act of Bullying or Harassment is Within the Scope of the District
1. The principal or designee will assign an individual(s) who is trained in investigative procedures to initiate an investigation of whether an act of bullying or harassment is within the scope of the School District.
 2. The trained investigator(s) will provide a report on results of investigation with recommendations for the principal to make a determination if an act of bullying or harassment falls within the scope of the District.
 - i. If it is within the scope of the District, a thorough investigation shall be conducted.
 - ii. If it is outside the scope of the District and determined a criminal act, the principal shall refer the incident(s) to appropriate law enforcement.
 - iii. If it is outside the scope of the District and determined not a criminal act, the principal or designee shall inform the parents/legal guardians of all students involved.
- F. Notification to Parents/Guardians of Incidents of Bullying or Harassment
1. Immediate notification to the parents/legal guardians of a victim of bullying or harassment.
 - i. The principal, or designee, shall promptly report via telephone, personal conference, and/or in writing, the occurrence of any incident of bullying or harassment as defined by this policy to the parent or legal guardian of all students involved on the same day an investigation of the incident(s) has been initiated. Notification must be consistent with the student privacy rights under the applicable provisions of the Family Educational Rights and Privacy Act of 1974 (FERPA).
 - ii. If the bullying incident results in the perpetrator being charged with a crime, the principal, or designee, shall by telephone or in writing by first class mail, inform the parents/legal guardian of the victim(s) involved in the bullying incident about the Unsafe School Choice Option (No Child Left Behind, Title IX, Part E, Subpart 2, Section 9532) that states “. . . a student who becomes a victim of a violent criminal offense, as determined by State law, while in or on the grounds of a public elementary school or

secondary school that the student attends, be allowed to attend a safe public elementary school or secondary school within the local educational agency, including a public charter school.”

2. Immediate notification to the parents/legal guardians of the perpetrator of an act of bullying or harassment.

The principal, or designee, shall promptly report via telephone, personal conference, and/or in writing, the occurrence of any incident of bullying or harassment as defined by this policy to the parent or legal guardian of all students involved on the same day an investigation of the incident(s) has been initiated. Notification must be consistent with the student privacy rights under the applicable provisions of the Family Educational Rights and Privacy Act of 1974 (FERPA).
 3. Notification to local agencies where criminal charges may be pursued.

Once the investigation has been completed and it has been determined that criminal charges may be pursued against the perpetrator, all appropriate local law enforcement agencies will be notified by telephone and/or in writing.
- G. Referral of Victims and Perpetrators of Bullying or Harassment for Counseling
- When bullying or harassment is suspected or when a bullying incident is reported, counseling services shall be made available to the victim(s), perpetrator(s), and parents/guardians.
1. The teacher or parent/legal guardian may request informal consultation with school staff, *e.g.*, school counselor, school psychologist, to determine the severity of concern and appropriate steps to address the concern. The teacher may request that the involved student’s parents or legal guardian are included.
 2. School personnel or the parent/legal guardian may refer a student to the school intervention team for consideration of appropriate services. Parent or legal guardian involvement shall be required when the student is referred to the intervention team.
 3. If a formal discipline report or formal complaint is made, the principal or designee must refer the student(s) to the school intervention team for determination of counseling support and interventions. Parent or legal guardian involvement shall be required.
 4. The intervention team may recommend
 - i. Counseling and support to address the needs of the victims of bullying or harassment;
 - ii. Research-based counseling or interventions to address the behavior of the students who bully and harass others, *e.g.*, empathy training, anger management; and/or
 - iii. Research-based counseling or interventions which include assistance and support provided to parents/legal guardians, if deemed necessary or appropriate.
- H. Reporting Incidents of Bullying and Harassment
1. Incidents of bullying or harassment shall be reported in the school’s report of data concerning school safety and discipline data required under s. 1006.09(6), F.S. The report shall include each incident of bullying or harassment and the resulting consequences, including discipline and referrals. The report shall also include each reported incident of bullying or harassment that did not meet the criteria of a prohibited act under this section with recommendations regarding such incidents.
 2. The District will utilize Florida’s School Environmental Safety Incident Reporting (SESIR) Statewide Report on School Safety and Discipline Data, which includes bullying/harassment as an incident code as well as bullying-related as a related element code.
 - i. Bullying and/or harassment incidents shall be reported and coded appropriately in SESIR using the relevant incident code and the bullying-related code as indicated in the *Code of Student Conduct*.
 3. Discipline and referral data shall be recorded in Student Discipline/Referral Action Report and Automated Student Information System.
 4. The District shall provide bullying incident, discipline, and referral data to the Florida Department of Education in the format requested, through Survey 5 from Education Information and Accountability Services, and at designated dates provided by the Department of Education.
- I. Instruction on Identifying, Preventing, and Responding to Bullying or Harassment

1. The District shall ensure that schools sustain healthy, positive, and safe learning environments for all students. It is committed to maintain a social climate and social norms in all schools that prohibit bullying and harassment. This requires the efforts of everyone in the school environment – teachers; administrators; counselors; school nurses; other nonteaching staff such as bus drivers, custodians, cafeteria workers; school librarians; parents/legal guardians; and students.
 2. Students, parents/legal guardians, teachers, school administrators, counseling staff, and school volunteers shall be given instruction at a minimum on an annual basis on the District's policy and regulations against bullying and harassment. The instruction shall include evidence-based methods of preventing bullying and harassment as well as how to effectively identify and respond to bullying in schools.
 3. The policy includes, but not limited to, student behavioral assemblies, Parent Teacher Meetings, Pre-Planning, Staff Awareness Training, grade level meetings with students on identifying, preventing, and responding to bullying or harassment, including instruction on recognizing behaviors that lead to bullying and harassment and taking appropriate preventative action based on those observations. These programs/trainings are available, but not limited to:

Students	School administrators
Parents	Counseling staff
Teachers	School volunteers
- J. Reporting to a Victim's Parents/Legal Guardians the Actions Taken to Protect the Victim
 The principal or designee shall by telephone and/or in writing report the occurrence of any incident of bullying as defined by this policy to the parent or legal guardian of all students involved on the same day an investigation of the incident has been initiated. According to the level of infraction, parents/legal guardians will be notified by telephone and/or writing of actions being taken to protect the child; the frequency of notification will depend on the seriousness of the bullying or harassment incident. Notification must be consistent with the student privacy rights under the applicable provisions of the Family Educational Rights and Privacy Act of 1974 (FERPA).
- K. Publicizing the Policy
1. At the beginning of each school year, the Superintendent or designee shall, in writing, inform school staff, parents/legal guardians, or other persons responsible for the welfare of a student of the District's student safety and violence prevention policy.
 2. Each District school shall provide notice to students and staff of this policy through appropriate references in the *Code of Student Conduct* and employee handbooks and through other reasonable means.
 3. The Superintendent shall also make all contractors contracting with the District aware of this policy.
 4. Each school principal shall develop an annual process for discussing the school district policy on bullying and harassment with students.
 5. Reminders of the policy and bullying prevention messages such as posters and signs will be displayed around each school and on the District school buses.

Disclaimer: The Gadsden County School District prohibits bullying & harassment of any kind; if you know, heard, and/or witness any infraction, Please fill out a form from the district's website or any school in Gadsden's County. You may remain anonymous, if you desire.

DUE PROCESS PROCEDURES FOR SUSPENSION/EXPULSION OF STUDENTS WITH DISABILITIES

Any student eligible under *Gadsden County Programs and Procedures for Exceptional Students*, who commits an offense which may be grounds for suspension/expulsion, shall have his/her case considered and decided on an individual basis.

A. Suspension

1. A student with a disability may be suspended from the Gadsden County schools for infractions described in the Code of Student Conduct and Student Rights and Responsibilities.
2. In order to protect the rights of students and parents, the principal, or his/her designee, shall follow the procedures for suspension as contained in School Board Policy.
3. Whenever a student with a disability is suspended, the principal, or his/her designee, shall immediately send written notification to the Director of Exceptional Student Education or Designee.
4. The principal, or his/her designee, shall be responsible for convening a **Manifestation/IEP** meeting when an exceptional student accumulates a total of ten (10) days of suspensions within a school year.
5. If the school did not conduct a functional behavioral assessment and implement a behavioral intervention plan for each child before the behavior that resulted in the suspension, the IEP team will develop a **behavior intervention and/or behavior intervention plan** to address that behavior; or if the child already has a behavioral intervention plan, the IEP team shall review the plan and modify it, as necessary, to address the behavior.

DRAFT

PROCEDURES FOR THE DISCIPLINE OF STUDENTS WITH DISABILITIES

(as defined under Section 504 Rehab Act 1973, ADA & IDEA)

6A-6.03312 Discipline Procedures for Students with Disabilities

For students with disabilities whose behavior impedes their learning or the learning of others, strategies, including positive behavioral interventions and supports to address that behavior must be considered in the development of their **individual educational plans (IEPs)**. School personnel may consider any unique circumstances on a case-by-case basis when determining whether a change in placement, consistent with the requirements and procedures in this rule, is appropriate for a student with a disability who violates the Code of Student Conduct.

The District may place a student with a disability at its Alternative School not more than forty-five (45) school days without regard to whether the behavior is determined to be manifestation of the student's disability if the offense falls into one of 3 categories:

- **Weapon possession - anything that can be used for or is readily capable of causing death or serious bodily injury.**
- **Possession, Use, Sale or Solicitation of Illegal Drugs – does not include alcohol or tobacco**
- **Serious Bodily Injury – injury to a person which consists of a physical condition that creates a substantial risk of death, serious personal disfigurement or protracted loss or impairment of the function of a bodily member or organ.**

PROCEDURES FOR THE DISCIPLINE OF PREKINDERGARTEN STUDENTS

The use of corporal punishment, humiliation, total or extended isolation, and/or withholding of food is prohibited as a form of discipline for prekindergarten students. (ACYF/HS 4.02;45 CFR 1304). When necessary, additional assistance will be acquired to provide for the needs of individual children.

Definitions specific to this policy:

Corporal Punishment - Paddling, slapping, pulling of hair, pinching, or any other means of causing bodily harm.

Denial of Participation in Extracurricular Activities - Denying a child the opportunity to participate in out-of-class activities such as field trips or parties. When necessary, additional assistance will be acquired to provide for the needs of individual children.

Extended Isolation in the Classroom - Denying a child the opportunity to participate in classroom activities for an unreasonable period of time. (e.g. long periods in time out).

Humiliation - Using derogatory remarks when referring to a child, name calling, or any other action that could lower the pride, dignity, or self-respect of a student.

Withholding of Food - Denying a child food that is provided to his/her peers such as dessert, snack, party foods, etc.

Total Isolation - Placing a child out of view of a responsible adult.

Suspension- The temporary removal of a child from his regular school program or the school bus.

Expulsion - The removal of the right and obligation of a child to attend a public school under conditions set by the School Board for a period of time not to exceed the remainder of the school year and one (1) additional year of attendance.

Suspension and/or expulsion are NOT RECOMMENDED in disciplining prekindergarten children. **Behavior Interventions and Social Skills Instruction should be utilized first to ensure** the safety, health, or welfare of any student, teacher, or staff member.

If a child's problem behavior is extensive or has escalated over a period of time, this may be an indicator of a physical or emotional problem and a referral to the prekindergarten office **as well as the MTSS/Problem Solving Team should be initiated.**

DISCIPLINARY PROCEDURES GRADES K-12

Disclaimer: The principal has authority, within Florida Statutes, to increase consequences based upon the severity of the infraction.

Discipline Guidelines and Procedures

CLASS I	MINOR OFFENSES
---------	----------------

Document All Actions Taken in Class I on the Classroom Behavior Management Form

- Chewing gum, eating food, or drinking beverages during class
- Arriving late to class (up to 5 minutes)
- Refusing to do classroom work
- Sleeping in class
- Using offensive language in general conversation with peers
- Disrupting the classroom (talking out loud, getting out of seat, laughing **without permission** or talking at inappropriate times)
- Displaying intimate affection in public
- Possessing inappropriate items, (**recording devices, air pods, electronic devices**)
- Disrupting the class by any other minor offense

Actions To Be Taken By Teachers

1st Offense

- Contact the parent/guardian. [**required**]
- Hold a teacher/student conference with documentation [**complete applicable section of Classroom Behavior Management Form (CBM)**].
- Collect inappropriate items from the student and return them at end of the day or when a parent/guardian collects them.

2nd Offense

- Use creative teacher interventions (may include behavior improvement plan, disciplinary work, etc.).
- Refer the student to the homeroom teacher (If student is an athlete, refer to coaches)
- Hold formal teacher-student conference and contact the parent/guardian. (**complete applicable section of CBM**)
- Refer the student to the team leader or designee, if applicable.
- Refer the student to the Guidance Counselor/Resource person/**MTSS-Problem Solving Team**
- Arrange peer mediation for the student.

3rd Offense

- Contact the parent/guardian. **[required]**
- Render a verbal reprimand.
- Provide notification of the consequences of the next offense.
- Arrange peer mediation for the student.
- Refer the student to the team leader or designee.
- Refer the student to a Guidance Counselor.
- **MTSS-Problem Solving Team**

**Students enrolled in Carter Parramore Academy for discipline reasons, Disciplinary Consequences will begin/be initiated at the 3rd Offense*

4th Offense

ACTIONS TO BE TAKEN BY ADMINISTRATORS

- Contact the parent/guardian **and the referral must be processed in FOCUS. [required]**
- Refer the student to an Administrator for disciplinary action/parent/guardian contact **and the referral must be processed in FOCUS. [required]**
- Suspend the student from home-based school activities (not to exceed 7 days/1 week/2 extracurricular activities)
- Assign the student to after-school detention - 2 Days
- Assign work detail to the student (**School Work Service – cafeteria detention and campus beautification**)
- Assign the student to in-school suspension (ISS) for 3 to 5 days/parent/guardian contact.

Disclaimer: The principal has authority, within Florida Statutes, to increase consequences based upon the severity of the infraction.

CLASS II	INTERMEDIATE OFFENSES
----------	-----------------------

- Repeating classroom disruptions
- Failing to serve detention or other disciplinary interventions
- Instigating conflicts by spreading rumors, false statements, accusations, threats and other statements that tend to escalate situations or incite chaos
- Throwing food or drinks in cafeteria
- Loitering in an unauthorized location
- Using obscene or profane language or gestures **towards staff**
- Possessing or using tobacco products, including vaping
- Cheating, plagiarism, abuse of technology, or forgery
- Skipping class/Leaving class (Skipping class is also considered arriving to class after 5 minutes.)
- Throwing or propelling objects or spitting
- Intimidating or harassing another student
- Dressing in opposition to the dress code (page 10)
- Repeating Class I offenses (**minimum of 3**)
- Unauthorized usage of electronic devices
- Drop Pants / Saggy Pants (reference page 10)
- Student use of **unauthorized** cell telephones/wireless communication devices
Personal cell telephones may be brought to school with the following conditions:
 - a. **For education purposes at the discretion of use by the school principal.** Phones must be turned off and kept out of sight during school hours and while riding on the school buses or using school transportation at any time.
 - b. If emergency calls to or from students are necessary, they should be placed through the school office and not to or from the student's telephone.
 - c. Phones should be kept secure to prevent theft (vehicles, purses, backpacks, lockers, etc.) The school is not responsible for lost or stolen phones or any other electronic device.
 - d. Phones should not be used to violate other's privacy (pg. 9)

Actions To Be Taken By Administrators

- An administrator calls the parent/guardian. **[required]**
- **The teacher/administrator writes a referral, administrator confers with the student and the referral must be processed in FOCUS. [required]**
- An administrator will assign In-school suspension (ISS).
- An administrator will assign 3 - 5 days out-of-school suspension (OSS) /parent/guardian contact.
- An administrator will assign 5 days OSS [school level hearing/ parent/guardian conference]
- An administrator will provide a hearing with the option to give OSS of 5 more days.
- The School Resource Officer will issue a citation **when appropriate.**
- An administrator will provide peer mediation for the student
- An administrator will involve the **Guidance Counselor and/or School Social Worker** in fact-finding and counseling of students.
- ~~Drop pants / saggy pants: verbal warning; suspension~~ – EXTRACT/REMOVE due to repetition
- **Teacher/Administrator will refer the student to the MTSS/Problem Solving Team. [required]**

Disclaimer: The principal has authority, within Florida Statutes, to increase consequences based upon the severity of the infraction.

CLASS III	GROUP A	MAJOR OFFENSES
-----------	---------	----------------

- Defying a school district employee ~~(an attitude~~ Action designed to provoke a confrontation)
- Defacing school property/malicious mischief
- Inciting or participating in riotous behavior
- Obstructing school employees from their duty (preventing fight breakups, etc.)
- Possessing merchandise stolen on school campus
- Trespassing
- Using school property without authorization (computers, A/V or PE equipment)
- Exhibiting lewd and lascivious behavior
- Possessing obscene literature or objects
- Stealing
- Repeating Class II offenses **(minimum of 3)**
- **L**eaving school campus without permission
- **U**nder the influence of alcohol and/or drugs

Actions To Be Taken By Administrators

1st Offense

- An administrator calls the parents/guardians **and the referral must be processed in FOCUS. [required]**
- The teacher/administrator writes a referral, administrator confers with the student **and the referral must be processed in FOCUS. [required.]**
- An administrator assigns 3-5 days out of school suspension.
- An administrator warns the student and parents/guardians of the consequence of the second offense. **[required.]**
- Guidance Counselors assist with fact finding and counseling of students.
- The student/parent/guardian makes restitution **when required.**
- The Resource Officer administers a civil citation **when appropriate.**
- A law enforcement officer is called to give assistance **when necessary.**
- ~~Corporal punishment (one to two paddlings)~~
- **Teacher/Administrator will refer the student to the MTSS/Problem Solving Team. [required]**

2nd Offense

- An administrator calls the parents/guardians. **[required]**
- The teacher/administrator writes a referral. **[required.]**
- An administrator confers with the student **and the referral must be processed in FOCUS. [required.]** .
- An administrator assigns 5 days out of school suspension and conducts a hearing.
- An administrator warns the student and parent/guardian of the consequences of the third offense.

- An administrator informs the student and parent/guardian that all subsequent referrals will result in recommendation for alternative placement and/or expulsion. **[required.]**
-
- The student/parent/guardian makes restitution **when required.**
- The Resource Officer administers a civil citation **when appropriate.**
- A law enforcement officer is called to give assistance **when necessary.**
- ~~Corporal punishment (two to three paddings)~~

**Students enrolled in Carter Parramore Academy for discipline reasons, Disciplinary Consequences will begin/be initiated at the 3rd Offense*

Disclaimer: The principal has authority, within Florida Statutes, to increase consequences based upon the severity of the infraction.

CLASS III	GROUP B	MAJOR OFFENSES
-----------	---------	----------------

- Fighting (involvement in physical confrontation in which the participant either initiated the fight or failed to take advantage of an opportunity to avoid escalation of the incident that led to the fight)
- Creating a hostile environment that includes harassing, physical, verbal, graphic or written conduct that is sufficiently severe, pervasive or persistent as to interfere with an individual’s ability to participate in or benefit from school activities. This includes all forms of sexual, racial, national origin, disability or other forms of discrimination or harassment prohibited by school board policies
- Threatening, harassing or intimidating a school district employee/adult
- Bullying & Harassment that is systematic in gesture or written, verbal, graphic, or physical acts. Also, a repeated behavior that has been already addressed.

Actions To Be Taken By Administrators

1st Offense

- An administrator calls the parents/guardians. **[required]**
- The teacher/administrator writes a referral. **[required.]**
- An administrator confers with the student **and the referral must be processed in FOCUS. [required.]**
- An administrator assigns 5-10 days out-of-school suspension. (High School)
- An administrator assigns 5 days out-of-school suspension. (Middle School)
- An administrator assigns up to 5 days out-of-school suspension. (Elementary)
- Guidance Counselors **and Social Workers** assist in fact finding and counseling of student.
- An administrator reads the second offense consequences to the students and parent/guardian. **[required.]**
- An administrator provides peer mediation.
- **Teacher/Administrator will refer the student to the MTSS/Problem Solving Team. [required]**

2nd Offense

- An administrator calls the parents/guardians. **[required]**
- The teacher/administrator writes a referral. **[required]**
- An administrator confers with the student **and the referral must be processed in FOCUS. [required.]**
- An administrator assigns 5 days out-of-school suspension with a hearing for possible alternative placement and/or expulsion considerations. **[required]**

Disclaimer: The principal has authority, within Florida Statutes, to increase consequences based upon the severity of the infraction.

CLASS III	GROUP C	MAJOR OFFENSES
-----------	---------	----------------

ZERO TOLERANCE OFFENSES

REFER TO THE GADSDEN COUNTY SCHOOL BOARD CODE OF STUDENT CONDUCT.

Florida Statute: [1006.13](#) - Zero Tolerance Policy

1. The Gadsden County School Board has a zero tolerance policy for:
 - (a) Crime and substance abuse, including the reporting of delinquent acts and crimes occurring whenever and wherever students are under the jurisdiction of the district school board.
 - (b) Victimization of students, including taking all steps necessary to protect the victim of any violent crime from any further victimization.
2. The zero tolerance policy requires students found to have committed one of the following offenses to be expelled, with or without continuing educational services, from the student's regular school for a period of not less than 1 full year, and to be referred to the criminal justice or juvenile justice system. (See definition of expulsion.)
 - (a) Bringing a firearm, or weapon (as defined in [F.S. 790.001](#)) to school, to any school function, or possessing a firearm, at school. (to include the possession, use, or sell of a firearm, or explosive on campus, at a school activity, or on school sponsored transportation, including designated bus stops, or
 - (b) Making a threat or false report (as defined by subsection [790.162](#) and [790.163](#)) respectively, involving school or school personnel's property, school transportation, or a school-sponsored activity by bringing, possessing, using or selling a firearm, imitation firearm, or explosive on campus

Offenses Prohibited

1. The Gadsden County School Board's zero tolerance for students that have been found to have committed any of the offenses listed below on school property, school sponsored transportation, including designated bus stops, or during a school sponsored activity. These students will be referred to the School Board for expulsion.
 - a. homicide (murder, manslaughter) – law enforcement must be notified
 - b. sexual battery – law enforcement must be notified
 - c. armed robbery
 - d. aggravated battery – law enforcement must be notified
 - e. assault, battery or aggravated battery on a teacher or other school personnel
 - f. kidnapping or abduction – law enforcement must be notified
 - g. arson
 - h. possession, use, or sale of any firearm
 - i. display, use, threaten, or attempt to use any firearm
 - j. possession, use, or sale of any explosive device (including firecrackers or fireworks)
 - k. possession, use, or sale of drugs or alcohol
 - l. threat or false report involving a school or school personnel's property, school transportation, or a school sponsored activity.
 - m. bomb threat
 - n. possession, use of hazardous chemical or substances material

(The above terms are defined in the glossary.)

2. Any student charged with an assault or battery on any employee of the School Board shall be removed from the classroom immediately and placed in an alternative school setting pending disposition. After an investigation, if the student is found guilty of this offense and in violation of F.S. [F.S. 784.081](#), he/she shall be expelled or placed in an alternative school setting ([F.S. 1006.13\(5\)](#)).

3. **All incidents involving firearms, explosives, unlawful possession, use or sale of controlled substances, including alcohol, and offenses listed in 1 above will be referred immediately to law enforcement.**
4. In the case of a physical altercation (fight) between two or more students on campus, school bus, or at any school sponsored activity, and where it is determined by the principal/designee that one or more of the students was/were the aggressor(s), and the remainder was/were the defender(s), the aggressive behavior of the student(s) shall be considered a zero-tolerance offense for which the student(s) will be subject to expulsion procedures as outlined in the Code of Student Conduct and the Fight Intervention Program.
5. In implementing this policy, the district will comply with all local, state, federal laws and guidelines.

WEAPONS PROHIBITED

1. Students must not bring or possess weapons on campus, at any school activity, or on school-sponsored transportation, including designated bus stops. For use in this policy, weapons shall include but not be limited to the following: air rifle, BB or pellet gun, rifle, shot gun, zip gun, stun gun, pistol, ammunition or explosive device (no matter how limited), incendiary device, ice pick, knife, box cutter, pocket knife, machete, hypodermic needle(s), laser pointer, brass knuckles, club, nunchakus, razor blade, self-defense sprays (such as mace or pepper gas), sling shot, spear, sword, or any item used with intent to cause bodily harm to another individual.
2. The principal or designee will immediately contain/remove the student from the class or school campus and investigate the alleged offense. After the investigation has been completed, the principal may complete procedures for suspension for up to five days.
3. The use and/or possession of a weapon other than a firearm, imitation firearm, or explosive device will result in suspension, expulsion, or other disciplinary action.
4. All incidents involving weapons will be referred to law enforcement. Willful and knowing possession of these weapons (listed in A above) may be a misdemeanor or third degree felony.
5. In implementing this policy, the district will comply with all local, state, federal laws and guidelines.
6. Pursuant to F.S. 790.001, simulating a firearm or weapon or wearing clothing or accessories that depict a firearm or weapon or expressing an opinion regarding a right guaranteed by the Second Amendment of the United States Constitution is not grounds for disciplinary action or referral to the criminal justice or juvenile justice system. Simulating a firearm or weapon while playing includes, but is not limited to:
 - Brandishing a partially consumed pastry or other food item to simulate a firearm or weapon
 - Possessing a toy firearm or weapon that is 2 inches or less in overall length
 - Possessing a toy firearm or weapon made of plastic snap-together building blocks
 - Using a finger or hand to simulate a firearm or weapon
 - Vocalizing an imaginary firearm or weapon
 - Drawing a picture, or possessing an image of a firearm or weapon
 - Using a pencil, pen, or other writing or drawing utensil to simulate a firearm or weapon

However, a student may be subject to disciplinary action if simulating a firearm or weapon while playing substantially disrupts student learning, causes bodily harm to another person, or places another person in reasonable fear of bodily harm. The severity of the consequences imposed on the student must be proportionate to the severity of the infraction and consistent with school board policies for similar infractions.

CERTAIN DRUGS PROHIBITED

1. The use, distribution, sale and/or unlawful possession of mood modifiers, MDMA/"Molly", FLAKKA, synthetic drugs, edibles, controlled substances or alcohol on campus, at school activities, or on school-sponsored transportation, including designated bus stops, is strictly prohibited. If, after an investigation, a student has been determined to be in violation of this section, he or she will be referred to the School Board for expulsion.
2. **All incidents involving unlawful possession, use or sale of controlled substances, including alcohol, will be reported to law enforcement.**
3. With written parent/guardian permission, using Form GCSB 893, a prescribed or nonprescribed medication may be given to a student by authorized school personnel. (See School Board rule 5.62.)
4. In implementing this policy, the district will comply with all local, state, federal laws and guidelines.

PROCEDURES FOR STUDENT TRANSFER WITH FELONY CHARGES

1. Section [1006.09](#), Florida Statutes provides for the transfer to an alternative program of a student enrolled at school who:
 - a. has been formally charged with a felony, or with a delinquent act which would be a felony if committed by an adult, by a prosecuting attorney; and
 - b. the incident for which he/she has been charged occurred on other than school property, and
 - c. under circumstances in which the student would not already be subject to the rules and regulations of the Gadsden County Schools; and
 - d. the incident would have an adverse impact on the educational program, discipline or welfare of the school in which the student is enrolled.
1. If the principal proposes a felony transfer, he/she will, in accordance with Section 1006.09(2), Florida Statutes, conduct an administrative hearing for the purpose of determining whether or not the student should be assigned to an alternative program pending determination of his/her guilt or innocence, or the dismissal of the charge, by a court of competent jurisdiction. The following procedures shall be followed if the principal proposes a felony transfer.
 - a. Upon receiving proper notice that a student has been formally charged with a felony or with a delinquent act which would be a felony if committed by an adult, the principal shall notify the parent/guardian of the student, in writing of the specific charges against the student and of the right to a hearing.
 - b. Such notice shall set a date for the hearing which shall not be less than two (2) schools days nor more than five (5) school days from date of postmark or delivery. It shall also advise the parent/guardian of the conditions under which a waiver of discipline may be granted.* A hearing can be held without the attendance of the parent/guardian after proper notification.

***Waiver of Discipline:**

Any pupil who is subject to discipline or expulsion for unlawful possession or use of any substance controlled under chapter F.S. 893, may request a waiver of the discipline code:

- i. If the pupil divulges information leading to the arrest and conviction of the person who supplied such controlled substance to him/her, or if the pupil voluntarily discloses his/her unlawful possession of such controlled substance prior to his/her arrest. Any information divulged which leads to such arrest and conviction is not admissible in evidence in a subsequent criminal trial against the pupil divulging such information, or

- ii. If the pupil commits himself/herself, or is referred by the court in lieu of sentence, to a state licensed drug abuse program and successfully completes the program. Florida Statutes 1006.09.
2. The hearing shall be conducted by the principal, or designee, and may be attended by the student, the parent/guardian, the student's representative or counsel, and any witnesses requested by the student or the principal.
3. The student may speak in his/her own defense, may present any evidence indicating his/her eligibility for waiver of disciplinary action, and may be questioned on his/her testimony. However, the student shall not be threatened with punishment or later punished for refusal to testify.
5. In conducting the hearing, the principal/designee shall not be bound by rules of evidence or any other courtroom procedure and no transcript of testimony shall be required.
6. Following the hearing, the principal shall provide the student and parent/guardian with a decision, in writing, as to whether or not student transfer for felony charges will be made, and if so, the effective date of such transfer. In arriving at this decision, the principal shall consider the conditions under which a waiver of discipline may be granted, and may grant such a waiver when she/he determines such action to be in the best interests of the school and the student.
7. If the court determines that the pupil did commit the felony or delinquent act which would have been a felony if committed by an adult, the principal may recommend that the student be expelled. This expulsion, however, shall not affect the delivery of educational services to the pupil in any residential, nonresidential, alternative, daytime, or evening program outside of the regular school setting. (F.S. 1006.09)
7. If a student is convicted or is found to have committed, a felony or a delinquent act, which would be a felony if committed by an adult, regardless of whether adjudication is withheld, participation in interscholastic, athletic, and extra-curricular activities will be withheld.
8. Pursuant to Florida law pertaining to a lawful arrest, if a student commits a delinquent act or violation of law which would be a felony if committed by an adult or involves a crime of violence, after the arresting authority notifies the district school superintendent, or the superintendent's designee, the information must be released within 48 hours after receipt to appropriate school personnel, including the principal of the child's school, or as otherwise provided by law. The principal must immediately notify all the child's assigned classroom teachers.

SUSPENSION/EXPULSION

The Gadsden County School Board may assign the student to a disciplinary program for the purpose of continuing educational services during the period of expulsion. District school superintendents may consider the 1-year expulsion requirement on a case-by-case basis and request the district school board to modify the requirement by assigning the student to a disciplinary program or second chance school if the request for modification is in writing and it is determined to be in the best interest of the student and the school system. If a student committing any of the offenses in this subsection is a student with a disability, the district school board shall comply with applicable State Board of Education rules.

Suspension, also referred to as out-of-school suspension, is the temporary removal of a student from all classes of instruction on public school grounds and all other school sponsored activities, except as authorized by the principal or principal's designee for a period not to exceed ten (10) school days. F.S. 1003.01 During the suspension, the student is remanded to the custody of the parent/guardian with specific homework assignments for the student to complete.

Expulsion is the removal of the right and obligation of a student to attend a public school under conditions set by the School Board, and for a period of time not to exceed the remainder of the term or school year and one (1) additional year of attendance. Expulsions may be imposed with or without continuing educational services and shall be reported accordingly.

1. The principal must follow all procedures for suspensions/expulsions. Only the School Board can expel students.
2. If a student is suspended or expelled from school, the student will not be allowed to attend any other school or school activity in the district until the time of suspension or expulsion has ended, or the School Board or the Superintendent has assigned an alternative setting. Failure to adhere to this rule could result in the extension of the suspension/expulsion and/or arrest.
3. Computerized records must be kept on all disciplinary actions that involve suspension/expulsion, and alternative placement.
4. The following are procedures for suspension:
 - a. Before suspending a student, the principal/designee will investigate the alleged offense, giving the student a chance to tell his/her side of the story and obtain written statements from witnesses, if appropriate.
 - b. When a student is suspended from school, an immediate attempt will be made to contact the parent/guardian(s). The student, the parents/guardians, and the Superintendent will be sent written notice (suspension form) within twenty-four hours.
 - c. The suspension by the principal may not be for more than ten days. No student will be suspended for more than five days without a school hearing which will adhere to the following procedures:
 - i. A suspension form will be completed giving the date for the hearing (usually on the third or fourth day of the suspension), and it will also include the time, place, and the purpose for the hearing.
 - ii. The hearing will be video and/or audio taped.
 - iii. The student may bring witnesses to speak for him/her, ask other witnesses questions, and tell his/her side of the story.
 - iv. This hearing should include the student and his/her parent/guardian(s) and may also include teachers, administrators, guidance counselors, school psychologists, and/or others as appropriate.
 - v. Decisions will be based on the information presented.
 - vi. At the end of the hearing, the principal will tell the student and the parent/guardian(s) verbally and later in writing what he/she has decided to do about the misbehavior. The Principal may extend the suspension up to 10 days.
5. The following are procedures for an expellable offense:
 - a. When a student commits an expellable offense (see Zero Tolerance Policy), the Principal/Designee investigates. If after the investigation it is deemed necessary to continue the expulsion process, the Principal/Designee notifies:
 - i. parent/guardian of suspension and sets a hearing date (hand delivered)
 - ii. the District Office
 - iii. ESE, ESOL and School Psychologist (if appropriate)
 - b. At the school hearing the following will be present:
 - i. student
 - ii. parent/guardian
 - iii. school personnel
 - iv. district personnel (include ESE Personnel if student with a disability)

- v. witnesses
 - vi. other appropriate personnel
- c. The following guidelines will be adhered to at the school hearing:
- i. The Principal/Designee will chair the hearing.
 - ii. All information discussed will be recorded.
 - iii. Everyone involved in the incident may give his/her side of the story.
 - iv. All pertinent information will be discussed including the student's discipline, attendance, and academic records and other significant information such as police and witness reports.
 - v. The recommendations of the Principal/Designee may also include, but not be limited to, alternative programs, counseling, community service, drug and rehabilitative treatment centers, extended suspension, and expulsion.
 - vi. If expulsion is recommended to the Superintendent, the suspension is extended for a total of 10 days. The parent/guardian is notified of the date of the School Board Meeting.
 - vii. The parent/guardian has the right to request a School Board Hearing prior to the School Board Meeting.
- d. If the Superintendent concurs with the Principal's decision, he will make a recommendation to the School Board. If the Superintendent does not agree with the expulsion recommendation, the student will be allowed to return to school.
- e. All recommendations for expulsion are placed on the School Board agenda for final action. The Superintendent will give to the Board, prior to the School Board meeting, background information on the student. The Board will act upon the recommendation of the Superintendent. The principal making the recommendation for expulsion must be present when the case goes before the School Board.

CORPORAL PUNISHMENT

- I. Corporal punishment is permitted pursuant to School Board Policy 5.31. [F.S. 1003.32](#)

Corporal punishment as used in this policy means paddling or spanking a child on the buttocks. Corporal punishment may be administered according to school board policy and procedures established by the superintendent. At a minimum, the following procedures shall apply:

- A. The use of corporal punishment shall be approved in principle by the principal before it is used, but approval is not necessary for each specific instance in which it is used.
- B. The child's parent must have provided written approval for the use of corporal punishment on an annual basis.
- C. The principal shall prepare guidelines for administering such punishment which identify the types of punishable offenses, the conditions under which the punishment shall be administered, and the specific administrative personnel on the school staff authorized to administer the punishment.
- D. The principal or other authorized administrator may administer corporal punishment only in the presence of another adult who is informed beforehand, and in the student's presence, of the reason for the punishment.
- E. The principal or other authorized administrator who has administered punishment shall, upon request, provide the student's parent with a written explanation of the reason for the punishment and the name of the other adult who was present and witnessed the punishment.

REASONABLE FORCE

[Florida Statute 1003.32\(j\)](#) authorizes teachers and other instructional personnel to use reasonable force to protect himself/herself or others from injury. The Department of Education has defined reasonable force

as, “appropriate professional conduct including physical force as necessary to maintain a safe and orderly environment.” The Department of Education has clarified that school personnel do have the right and the authority to protect against: conditions harmful to learning, self, and others. Note: [F.S. 1006.11\(2\)](#) further provides that a principal, teacher, other staff members, or bus driver shall not be civilly or criminally liable for any action carried out in conformity with School Board rules regarding the control, discipline, and expulsion of students, except in the case of excessive force or cruel & unusual punishment.

COLLECTION OF EVIDENCE / SEARCH AND SEIZURE

The right of students as citizens to be free from unreasonable search shall be preserved in the schools. However, the principal or designee has the right to collect evidence as necessary to provide for the safe and orderly operation of the school and all of its functions. These may include, but not be limited to, the following measures:

1. **General Search:** In all cases of search the responsible school officials shall maintain an accurate written summary of the events surrounding the search incident.
2. **Lockers:** Lockers remain the property of the school and are provided to students without charge. The rights of personal property, however, as well as the rights of the school, must be afforded consideration. The school principal or his designee is authorized to open lockers in the presence of another witness and to examine their contents to include personal belongings of students when such person has reasonable suspicion to believe that the contents threaten the safety, health, or welfare of any student or include property stolen from the school personnel or other students. This policy does not preclude administrators from being able to randomly search lockers. Appropriate notices will be posted to this effect.
3. **Personal Search:** With reasonable suspicion, the administrator/designee may conduct a personal search of a student. Personal search may include: emptying of pockets, removal of shoes and socks, and removal of jacket. **FRISKING AND STRIP SEARCHES ARE PROHIBITED.**
4. **Use of Metal Detectors:** As part of an overall plan to protect the health, welfare, safety, and lives of students, faculty, staff, and visitors to the public schools, and to enforce provisions of the Code of Student Conduct, metal detectors may be used to scan and screen for firearms, imitation firearms, and other weapons which have no place in public schools due to the fact that they are life threatening, cause bodily harm, and have adverse and disruptive effects on the educational process.
5. **Search of Vehicles:** Any motor vehicle parked on school property may be searched by the site administrator or designee with reasonable suspicion. Appropriate notices will be posted to this effect.
6. **Use of Video Cameras:** For the health, welfare, and safety of students, faculty, and staff, video cameras may be used on school buses and in school facilities as appropriate.
7. **Drug-Sniffing Dog:** In searching for illegal objects or substances in students' lockers or other school areas, a trained drug-sniffing dog may be used. The search procedure shall consist of the following:
 - a. Contact the Superintendent or his designee for approval.
 - b. The search will be conducted to avoid contact between students and the dog.
 - c. Contact the local law enforcement office and obtain a certified officer and a certified drug-sniffing dog, if drugs are suspected.

AUTHORITY OF THE SCHOOL BUS DRIVER

1. The principal/designee gives to the bus driver authority to control students to and from school or on school trips. Any student who misbehaves may be reported to the principal.
2. The bus driver will not suspend a student from riding the bus, spank a student, or put a student off the bus at any place other than his regular stop. However, students' that have written permission from a parent/guardian and the request has been approved by the principal or designee and the Transportation Department may be transported to an alternate stop provided the bus has sufficient occupancy. If there is an emergency on the bus because of student behavior, the bus driver must take care of the emergency and protect the students on the bus. The bus driver will immediately report the incident to the proper authority.

MISCONDUCT ON SCHOOL BUSES

If a student misbehaves on the school bus, the bus driver may report the misbehavior to the principal. The principal may suspend the student from riding the bus for no more than ten (10) school days per offense. Please note: If ESE students do not get a ride to school during the bus suspension, the suspension will count towards the maximum allowable ten (10) day school suspension for the year. If the suspension is for more than five (5) days, a hearing is required. The School Board may change the suspension to an expulsion from the school bus. The student may also be subject to other disciplinary actions which may include suspension or expulsion from school.

Disclaimer: The principal has authority, within Florida Statutes, to increase consequences based upon the severity of the infraction.

BUS OFFENSES

MINOR OFFENSES

- Shouting/loud talking
- Eating / drinking
- Littering
- Holding hand/head outside of the bus

Actions To Be Taken

- **BUS DRIVERS' INTERVENTIONS (use one or more)**
- Conduct a conference with the student.
- Assign a new seat assignment.
- Write a referral and give it to an administrator.
- **ADMINISTRATORS' INTERVENTIONS**
- 1st referral: Notify parents/guardians and have a conference with the student.
- 2nd referral: 1- 3 days off bus -provide copy of referral to student and bus driver within 24 hours (hardcopy and/or electronic)
- 3rd referral: 3 days off bus
- 4th referral: 5 days off bus (**Hearing Requested**)

MAJOR OFFENSES

- Being out of seat when bus is in motion
- Using foul language/ racial slurs
- Defacing property
- Throwing objects
- Holding hand/head outside bus while in motion
- Fighting

- Distracting the bus driver with deviant behavior

Actions To Be Taken By Administrators

- Restitution is paid by the student/parent/guardian.
- 1st referral: 1-3 day off bus
- 2nd referral: 3-5 days off bus **provide copy of referral to student and bus driver within 24 hours (hardcopy and/or electronic)**
- 3rd referral: 5 days off bus
- 4th referral: 5 days off bus (**Hearing Requested/expulsion considered**)

The student may also be subject to other disciplinary actions which may include suspension or expulsion from school.

ZERO TOLERANCE ON THE BUS

- Threatening/assaulting the driver
- Possessing weapons / **Imitation of Weapons**
- Possessing/using drugs/alcohol

ENROLLMENT OF STUDENTS EXPELLED/DISMISSED FROM OTHER SCHOOL DISTRICTS OR PRIVATE SCHOOLS

The records of students seeking to enroll in Gadsden County Public Schools, who have been assigned to an alternative school by another public school district, a private school, or a charter school, must be reviewed by the Superintendent or Designee, Coordinator of Dropout Prevention, and the Principal of Alternative Education. The student will be assigned to the district alternative school or a reentry program for the period of time as determined to be appropriate.

The records of students seeking to enroll in Gadsden County Public Schools who are currently being recommended for expulsion or dismissal, or who have been expelled or dismissed from another public school district, a private school, or a charter school, must be reviewed by the Superintendent or Designee, Coordinator of Dropout Prevention, and the Principal of Alternative Education. The student will be assigned to the district alternative school or other alternative school program or a reentry program for a period of time as determined to be appropriate.

If a final order of expulsion has been imposed upon the student from a previous school/district, the Superintendent or Designee, Coordinator of Dropout Prevention, and the Principal of Alternative Education may choose to:

1. Honor the expulsion or dismissal of the student from the previous school/district;
2. Assign the student to a district alternative school; or
3. Assign the student to a zoned school of attendance.

GLOSSARY

Abuse of property/minor vandalism - to use wrongly or improperly, or to maltreat any school equipment or property, including school buses.

Aggravated battery - Intentionally or knowingly causing great bodily harm, permanent disability, or permanent disfigurement or using a deadly weapon while committing a battery.

Alcohol possession, use, sale, storage, or distribution - having on one's person or within one's personal property or under one's control by placement of and knowledge of the whereabouts or reasonable belief that one has assimilated, or reasonably appears, in the judgment of appropriate school officials, to be under the influence of any alcoholic substance

Armed robbery - the taking of money or other property which may be the subject of larceny from the person or custody of another, with intent to either permanently or temporarily deprive the person or the owner of the money or other property, when in the course of the taking there is the use of force, violence, assault, or putting in fear; with the use of a firearm, imitation firearm, or other deadly weapon

Arson - to willfully and unlawfully, or while in the commission of any felony, by fire or explosion, damage or cause to be damaged: any dwelling, whether occupied or not, or its contents; any structure, or contents thereof, where persons are normally present; and any other structure that the person knew or had reasonable grounds to believe was occupied by a human being

Articles disruptive to school - to possess, display or use anything that is disruptive to the general peace and welfare of a school center, school bus, or a school sponsored activity

Assault - an intentional, unlawful threat by word or act to do violence to the person of another, coupled with an apparent ability to do so which creates a well-founded fear in such other person that such violence is imminent. ([F.S. 784.011](#))

Assault on school board employee - any intentional, unlawful threat, by word or act, to do violence to a school board employee, coupled with an apparent ability to do so, and doing some act that creates a well-founded fear in another person that violence is imminent

Attempted criminal act against a person - any person who attempts to commit, or who solicits another to commit, or who agrees, conspires, combines, or confederates with another person or persons to commit the offense of a battery against another person or persons, and in such attempt does any act toward the commission of such offense, but fails in the perpetration or is intercepted or prevented in the execution of the offense

Attendance - the action or state of going regularly to or being present at a place or event.

Battery (BAT)-Level I - (physical attack/harm) The physical use of force or violence by an individual against another. The attack must be serious enough to warrant consulting law enforcement and result in more serious bodily injury. (To distinguish from Fighting, report an incident as Battery only when the force or violence is carried out against a person who is not fighting back.) Law enforcement must be notified.

Battery or aggravated battery on a school board employee - a battery or aggravated battery on any elected official or school district employee whether it is committed on school property, on school sponsored transportation, during a school-sponsored activity or while the elected official or employee is on official school business

Bomb threat - intentionally making a false report to any person concerning the placement of any bomb, dynamite, explosive, or arson-causing device

Breaking and entering/burglary - the unlawful entry into a building or other structure with the intent to commit a crime

Bullying - Systematically and chronically inflicting physical hurt or psychological distress on one or more students, or employees. It is further defined as unwanted and repeated written, verbal, or physical behavior, including any threatening, insulting, or dehumanizing gesture, by a student or adult, that is severe or pervasive enough to create an intimidating, hostile, or offensive educational environment; cause discomfort or humiliation; or unreasonably interfere with the individual's school performance or participation; and may involve but is not limited to:

- a. Unwanted teasing;
- b. Social Exclusion;
- c. Threatening;
- d. Intimidation;
- e. Stalking;
- f. Cyberstalking;
- g. Cyberbullying;
- h. Physical violence;
- i. Theft;
- j. Sexual, religious, or racial harassment;
- k. Public humiliation;
- l. Rumor or spreading falsehoods; or
- m. Destruction of school or personal property.

Bus disruption - behavior that disrupts and/or distracts the driver from safely operating the school bus

Cheating (copying work of another, using materials not authorized to use) - copying of anyone else's work or cheating on any test or assignment

Chemical/hazardous material - Any chemical compounds or dangerous materials that may be used to cause harm or vulnerability to any person(s).

Computer misuse/inappropriate use of e-mail/internet - the inappropriate use of a computer, including, but not limited to, breaking into restricted accounts or networks, modifying, or destroying files without permission, illegally copying software, and entering or distributing or printing unauthorized files; accessing or entering unauthorized internet sites; distributing inappropriate electronic messages

Confrontation/tussle - a verbal confrontation, struggle, or scuffle involving more than one person; pushing, shoving, pulling, etc. that has the propensity to escalate into a fight

Contraband, non-criminal - possession and/or use of items or contraband designated by the school as inappropriate materials such as portable paging devices, beepers, portable cellular telephones, etc.; these will be confiscated

Corporal punishment - Paddling by the principal/designee on the student's buttocks.

Criminal assault on a student/person - any intentional, unlawful threat, by word or act, to do violence to another person, coupled with an apparent ability to do so, and doing some act that creates a well-founded fear in another person that violence is imminent

Criminal battery on a student/person (non-School Board Employee) - an actual and intentional touching or striking of another person against his or her will or intentionally causing bodily harm to an individual, including child abuse; the malicious and unprovoked physical attack by an aggressor upon another person

Destructive device - A destructive device is any bomb, grenade, mine, rocket, missile, pipe bomb, or similar device containing some type of explosive that is designed to explode and is capable of causing bodily harm or property damage ([F.S. 790-001\(4\)](#)).

Disobedient/open defiance/insubordination - refusal or failure to obey, marked by resistance to authority; the flagrant or hostile challenge of the authority of a school staff member, bus driver, or any other adult in authority

Disobeying rules on the school bus - violation of the posted or written rules of conduct for the bus that is not necessarily a disruptive behavior; e.g.: not in assigned seat, eating or drinking on the bus

Disorderly conduct/disruption of school - any act which substantially disrupts the orderly conduct of a school function, behavior which substantially disrupts the orderly learning environment or poses a threat to the health, safety, and/or welfare of students, staff, or others

Disrespectful language - written or verbal remarks or gestures that show a lack of respect, rudeness or are inappropriate; The use of words or acts which demean, degrade, antagonize, or humiliate a person or group of persons

Disruptive behavior - behavior by its nature disrupts the educational process, but is not criminal.

Disruptive play - non-confrontational activity that is not appropriate in a school setting and is disruptive to the educational process; engaging in rowdy, rough behavior that interferes with the safe and or purposeful order of a school; e.g.: horseplay, chasing another student in the hallway of classroom, etc.

Dress code violation - to dress in a manner that would constitute a disruption in the school, create a safety hazard or exhibit impropriety; violations of the school dress code

Drug paraphernalia use, sale, storage, or distribution - to possess, use, sale, store, or distribute any equipment, device, or equipment used for the purpose of preparing or taking drugs

Drug Use/Possession Excluding Alcohol (DRU)-Level III - (illegal drug possession or use) The use or possession of any drug, narcotic, controlled substance, or any substance when used for chemical intoxication. Use means the person is caught in the act of using, admits to use or is discovered to have used in the course of an investigation.

Due process - A student has the right to a fair, reasonable, and impartial hearing for a broken or disobeyed rule. ([F.S. 1006.07](#))

Edibles - commercially produced food items made with marijuana oil, but no other form of marijuana, that are produced and dispensed by a medical marijuana treatment center.

Explosive ([F.S. 790.001\(5\)](#)) - any chemical compound or mixture that has the property of yielding readily to combustion or oxidation upon application of heat, flame, or shock, including but not limited to dynamite, nitroglycerin, trinitrotoluene, or ammonium nitrate when combined with other ingredients to form an explosive mixture, blasting caps, and detonators; but not including:

(a) Shotgun shells, cartridges, or ammunition for firearms;

(b) Fireworks as defined in [F.S. 791.01\(4\)\(a\)](#); means and includes any combustible or explosive composition or substance or combination of substances or, except as hereinafter provided, any article prepared for the purpose of producing a visible or audible effect by combustion, explosion, deflagration, or detonation. The term includes blank cartridges and toy cannons in which explosives are used, the type of balloons which require fire underneath to propel them, firecrackers, torpedoes, skyrockets, roman candles, dago bombs, and any fireworks containing any explosives or flammable compound or any tablets or other device containing any explosive substance.

(c) Smokeless propellant powder or small arms ammunition primers, if possessed, purchased, sold, transported, or used in compliance with [F.S. 552.241](#).

Explosive devices possession, use, sale, or distribution (not firecrackers, fireworks) - an explosive is any chemical compound or mixture that has the property of yielding readily to combustion or oxidation upon application of heat, flame, or shock, including but not limited to dynamite, nitroglycerin, trinitrotoluene, or ammonium nitrate when combined with other ingredients to form an explosive mixture, blasting caps, and detonators

Expulsion - Removal of the right and obligation of a student to attend a public school under conditions set by the School Board for a period of time not to exceed the remainder of the school year and one (1) additional year of attendance. Expulsion can also mean alternative placement.

Extortion/blackmail/coercion - the use of threat or intimidation to obtain anything of value from another person, including, but not limited to, money

Extracurricular - any school-authorized or education-related activity occurring during or outside the regular instructional school day. [\(F.S. 1006.15\)](#)

FLAKKA – Synthetic drug that can be snorted, smoked, injected or swallowed. This designer drug is sweeping the State of Florida.

Failure to comply with class/school rules - violation of specified posted or written school or class rule that is not necessarily a disruptive behavior; e.g.: repeatedly chewing gum, repeatedly tardy for class, etc.

False fire alarm/911 call - whoever, without reasonable cause, by outcry or the ringing of bells, or otherwise makes or circulates, or causes to be made or circulated, a false alarm of fire or 911 call

False report involving school, school personnel's property, school transportation or school sponsored activity- Making a false report with intent to deceive, mislead, or otherwise misinform any person, concerning the placing or planting of any bomb, dynamite, or other deadly explosive.

Fighting - mutual participation in a hostile, physical encounter; mutual participation in an altercation involving physical violence

Firearm - means any weapon (including a starter gun) which will, is designed to, or may readily be converted to expel a projectile by the action of an explosive; the frame or receiver of any such weapon; any firearm muffler or firearm silencer; any destructive device; or any machine gun. The term "firearm" does not include an antique firearm unless the antique firearm is used in the commission of a crime. [\(F.S. 790.001\(6\)\)](#)

***Firearm, possession, use, or sale of** - Possession, use, or sale of any firearm, on school property, school-sponsored transportation or during a school-sponsored activity. A firearm, is any weapon (including a starter gun) which will, is designed to, or may readily be converted to expel a projectile by the action of an explosive; the frame or receiver of any such weapon; any firearm muffler or firearm silencer; any destructive device; or any machine gun. [\(F.S. 790.001\(6\)\)](#)

Fireworks/firecrackers - possession, use, sale, storage, or distribution of fireworks or firecrackers or associated devices

Forgery of a document or signature - to fashion or reproduce for fraudulent purposes

Gambling - one who participates in games of chance or skill for money or profit

Grievance procedure - The process of filing appropriate forms resulting from a complaint filed by a student. Forms may be obtained from the principal.

Harassment - Any threatening, insulting or dehumanizing gesture, use of technology, computer software, or written, verbal or physical conduct directed against a student or school employee that:

1. Places a student or school employee in reasonable fear of harm to his/her person or damage to his/her property;
2. Has the effect of substantially interfering with a student's educational performance, or employee's work performance, or either's opportunities, or benefits;
3. Has the effect of substantially negatively impacting a student's or employee's emotional or mental well-being; or
4. Has the effect of substantially disrupting the orderly operation of a school.

Hazing - to persecute or harass with meaningless, difficult, or humiliating tasks whether its mental and/or physical.

Homicide/murder - the unlawful killing of a human being; and manslaughter – the killing of a human being by the act, procurement, or culpable negligence of another, without lawful justification. Law enforcement must be notified.

Illicit drug - A drug not allowed by law, custom, rule, etc.

Imitation firearm – Any toy gun, replica of a firearm, air-soft gun that fires nonmetallic projectiles, or other device that is so substantially similar in coloration and overall appearance to a firearm.

Inappropriate activity - any activity that is disruptive and/or inappropriate in a school setting that does not fit into another category

Incendiary device - means any material, substance, device, or combination thereof which is capable of supplying the initial ignition and/or fuel for a fire and is designed to be used as an instrument of willful destruction.

Intentionally striking a staff member intervening in a fight - intentionally striking or violently struggling with a staff member intervening in a fight or confrontation

Kidnapping or abduction - forcibly, secretly, or by threat, confining, abducting, or imprisoning another person against their will and without lawful authority, with intent to hold for ransom or reward or as a shield or hostage; commit or facilitate commission of any felony; inflict bodily harm upon or to terrorize the victim or another person. Law enforcement will be notified.

Leaving School Grounds without permission - unauthorized leaving of the school grounds

Lying/misrepresentation - intentionally providing false or misleading information to, or withholding valid information from a school staff member

MDMA/”Molly” – Methylenedioxy-methamphetamine is a pure form of an ingredient found in Ecstasy.

Motor vehicle theft - theft or attempted theft of a motor vehicle; anything that is self-propelled

Obscene, lewd, or inappropriate act - the use of oral or written language, electronic messages, pictures, objects, gestures, or engaging in any physical act considered to be offensive, socially unacceptable, or not suitable for an educational setting

Other potentially dangerous weapons/items - any instrument or object, other than firearms or knives, deliberately used to inflict harm on another person, or used to intimidate any person

Out of Assigned Area - out of assigned area without permission and/or in a restricted access area without permission

Permissible absence - An absence which has the sanction of the parents/guardians and the school. This may include activities such as an individual educational trip or other extenuating circumstance. Any such individual educational trip must be planned by the parent/guardian and teacher, and a written report of the trip must be presented to the teacher. Work missed may be made up by the student.

Petty theft/stealing 1 (\$0-\$10) - the unlawful taking, carrying, or lending of property less than \$10.00 in value from the possession or constructive possession of another person

Petty theft/stealing 2 (\$10 -\$25) - the unlawful taking, carrying, lending, or riding away of property more than \$10, but less than \$25 in value from the possession, or constructive possession of another person

Petty theft/stealing 3 (\$25-\$50) - the unlawful taking, carrying, lending, or riding away of property more than \$25, but less than \$50 in value from the possession, or constructive possession of another person

Physical aggression (not involving law enforcement) - the intentional physical aggression of one party against another person such as pushing, punching, or striking

Plagiarism - The unauthorized use of someone else's material, which is then presented as being the result of the plagiarist's own primary research, creative impulse or insight. Plagiarism technically encompasses the borrowing of ideas of others, as well as their exact words or allowing one's own personal work or homework to be copied

Possession/use of tobacco products - possession, use, sale, storage, or distribution of tobacco products on school district property

Profane/obscene language - abusive, profane, obscene, or vulgar language (verbal, written, or gestures) or conduct in the presence of another person

Prohibited items - An item prevented by law or by an order.

Public display of affection - engaging in overtly amorous contact or language not appropriate in a school setting

Remote learning - is where the student and the educator, or information source, are not physically present in a traditional classroom environment. Information is relayed through technology, such as discussion boards, video conferencing, and online assessments.

Robbery - the taking or attempting to take anything of value that is owned by another person or organization, under confrontational circumstances by force or threat of force or violence and /or by putting the victim in fear

Synthetic Drug - substances that mimic marijuana, cocaine and other illegal **drugs** are making users across the nation seriously ill, causing seizures and death.

Sexual battery (attempted or actual forcible penetration) - forced- oral, anal, or vaginal penetration by, or union with, the sexual organ of another or the anal or vaginal penetration of another by any other object. Law enforcement must be notified.

Sexual harassment - any slur, innuendo, or other physical conduct reflecting on an individual's gender which has the purpose of creating an intimidating, hostile, or offensive educational work environment; has the purpose or effect of unreasonably interfering with an individual's work or school performance or participation; or otherwise affects an individual's educational opportunities; sexual advances, requests for sexual favors, and other verbal or physical conduct of a sexual nature

Sexual misconduct - engaging in a sex act or physical conduct of a sexual nature; the unlawful sexual intercourse, sexual contact or other unlawful behavior or conduct intended to result in sexual gratification without force or threat and where the victim is capable of giving consent

Stealing more than \$50 - the unlawful taking, carrying, leading, or riding away of property more than \$50, in value from the possession or constructive possession of another person or entity (meaning school)

Suspension - Removal of students from their regular school program for a period not to exceed 10 school days. Pursuant to [Florida Statutes 1006.09](#), no student who is required by law to attend school shall be suspended for unexcused absence or truancy.

Tardiness, Habitual - consistently late to class or school

Tear gas gun or chemical weapon or device - any weapon of such nature, except a device known as a "self-defense chemical spray." "Self-defense chemical spray" means a device carried solely for purposes of lawful self-

defense that is compact in size, designed to be carried on or about the person, and contains not more than two ounces of chemical. [\(F.S. 790.001\(3\)\(b\)\)](#)

Threat against school, school personnel's property, school transportation or school sponsored activity - Threatening to throw, project, place, or discharge any destructive device with intent to do bodily harm.

Threat, non-criminal - a threat (less serious than assault) by word or act to do violence to another person or his/her property; e.g.: "You better watch your back", "I'm going to get you after school."

Trespassing - to enter or remain on a public school campus or school board facility without authorization or invitation and with no lawful purpose for entry, including students under suspension or expulsion, employees not required by their employment to be at the particular location; and unauthorized persons who enter or remain on campus or school district facility or sponsored activity after being directed to leave

Truancy/Unexplained Absence - An absence from class or school that the reason or excuse is inadequate or does not meet the criteria for an excused absence

Unauthorized possession or use of prescription medication - to possess, use, sell, store, or distribute or be under the influence of any substance which requires a physician's prescription, or any over-the-counter medication without parent/guardian approval and school notification

Unauthorized sale/distribution of materials (non-criminal) - unauthorized selling or distributing of materials not generally considered illegal; e.g.: candy

Unexcused absence - An absence which does not have the approval of the school, or which is due to disciplinary action against the student. Ordinarily, in such case, the work missed may not be made up by the student for credit.

Unintentionally striking a staff member intervening in a fight - unintentional striking or violently struggling with a staff member intervening in a fight or confrontation

Unknown weapon possession - type of instrument or object unknown at the time of the report

Unserviced detention (extended) - unexcused absence from a scheduled extended detention

Unserviced detention (regular) - unexcused absence from a scheduled regular detention

Unserviced detention (Saturday) - unexcused absence from a scheduled Saturday detention

Use of intoxicants - the inappropriate use of intoxicants, including but not limited to, glue, solvents, butane, and whipped cream, for the purpose of obtaining a mood-modifying experience

Vandalism more than \$100 (includes time and labor) - the willful and/or malicious destruction, damage, or defacement of public or private property, real or personal, including bus seats and buses, without the consent of the owner or the person having custody or control of it. This includes graffiti.

Weapon - A weapon may be, but is not limited to, any firearm, any explosive or destructive device, any knife, razor blade or box cutter, any dirk (dagger), metallic knuckles, slung shot (a small mass of metal, stone, sand, or similar material fixed on a flexible handle, strap, or the like, used as a weapon.), billie [billie (also spelled billy) club, night stick, a stick of less than arm's length, usually made of wood, plastic, or metal], tear gas gun, chemical weapon or device, or other deadly weapon except a firearm or a common pocketknife, plastic knife, or blunt-bladed table knife [F.S. 790.001(13)] or any item used with intent to cause bodily harm to another individual.

Weapon/knife possession - the possession of any knife that may inflict harm on another person, or be used to intimidate another person, including, but not limited to, fixed blade knives, folding knives, switch blade knives, and common pocket knives or any item used with intent to cause bodily harm to another individual.

APPENDICES

DRAFT

Gadsden Public School District
Declaration of Intent to Terminate School Enrollment



Compulsory Attendance Requirements

- All youths between the age of 6 and under 16 per [Florida Statute 1003.21](#) must attend school.
- Students ages 16 and 17 are not required to attend school when and if a FORMAL DECLARATION OF INTENT TO TERMINATE SCHOOL ENROLLMENT FORM AND DOE EXIT SURVEY is on file with the district, and must be completed by Parent/Guardian and Student.

These forms are available with the Guidance Counselor at your child's school.

Elijah Key, Superintendent of Schools
35 Martin Luther King, Jr. Boulevard
Quincy, Florida
32351

Phone: (850) 627-9651 Fax: (850) 627-2760

**Florida Department of Education
Exit Interview Student Survey**

School Name:	School District:
Student Name:	Student DOB:
Grade Level:	Date:

Directions: Please check the response that best describes your experience or provide a description of your experience in the tables provided.

1. Which of the following best describes your **primary** reason for terminating school enrollment?

- | | |
|---|--|
| Classes were not interesting/bored | Student-teacher conflict |
| Missed too many days and could not catch up | Employment/have to work full-time |
| Did not like school | Friends dropped out |
| Failing classes/couldn't keep up with school work | Failed to pass Florida Required Assessment |
| Illness | Intimidated/Threatened/Bullied |
| Became a parent | Migrant |
| Getting married | Homeless |
| Felt like I did not belong | Family Problems |
| Expelled from school | Other |

2. Which of the following best describes your **secondary** reason for terminating school enrollment?

- | | |
|---|--|
| Classes were not interesting/bored | Student-teacher conflict |
| Missed too many days and could not catch up | Employment/have to work full-time |
| Did not like school | Friends dropped out |
| Failing classes/couldn't keep up with school work | Failed to pass Florida Required Assessment |
| Illness | Intimidated/Threatened/Bullied |
| Became a parent | Migrant |
| Getting married | Homeless |
| Felt like I did not belong | Family Problems |
| Suspended from school often | Other |
| Expelled from school | |

3. What would have improved your chances of staying in school? (Check all that apply.)

- | | |
|---|---|
| Opportunities for real-world learning (internships, service learning) | Better communication with your parents |
| Better teachers | Increased parental involvement |
| Smaller classes | Less freedom and more supervision from parents |
| More individualized instruction | Less freedom and more supervision from school officials |
| Better communication with your teachers | Other |

Exit Interview Student Survey (continued)

4. What actions did your school personnel take to keep you enrolled in school?

- Provide student counseling
- Scheduled a conference with parent(s), guardian(s), student, and school staff
- Discussed and offered options for tutoring
- Discussed the consequences of dropping out
- Discussed and offered options for continuing education in a different environment (e.g., Adult Education, home school, virtual school, hospital homebound)
- Discussed and offered alternative options for graduation (e.g., diploma options, GED Exit Option or GED Testing)
- Conducted home visits
- Referred student to agencies/programs to address problems interfering with school success (e.g., substance abuse counseling, psychological counseling, family counselor)
- Discussed and offered participation in a credit recovery course/program
- Discussed and offered access to Dropout Prevention Program(s) (e.g., alternative education, disciplinary, teenage parent)
- Tracked student progress (by teacher, counselor, social worker, graduation coach, etc.)
- Changed or revised course schedule
- Implemented intervention contracts (e.g. attendance or behavior)
- Student reported that school staff took no action
- Other

Please check and sign below to certify that each of the following statements were addressed by school personnel.

I am at least 16 years of age and it is my intent to terminate my school enrollment. I received counseling from a guidance counselor or other school personnel which addressed the following:

- Terminating school enrollment prior to graduation will likely reduce my potential earnings and negatively affect my career options.
- Termination of school enrollment will result in the revocation/denial of my driving privileges until age 18
- My reasons for leaving school prior to graduation.
- Possible actions that could keep me from leaving school prior to graduation.
- Options for continuing my education in a different environment, e.g., Adult Education or GED testing.
- For Bright Futures eligibility, GED students must complete credit requirements before taking GED exam.

Student Signature:	Date:
Parent/Guardian Signature: (if student is under 18 years of age)	Date:
School Personnel Signature:	Date:

Optional:

1. What is the highest level of education completed by your maternal parent/guardian? (check one)
 Elementary Middle School High School College Graduate School Unknown
2. What is the highest level of education completed by your paternal parent/guardian? (check one)
 Elementary Middle School High School College Graduate School Unknown

DECLARATION OF INTENT TO TERMINATE ENROLLMENT

HEREBY ANNOUNCE MY INTENT TO TERMINATE ENROLLMENT IN SCHOOL AND ACKNOWLEDGE THAT THIS ACTION IS LIKELY TO REDUCE MY FUTURE EARNING POTENTIAL. I ALSO UNDERSTAND THAT I MAY LOSE MY DRIVING PRIVILEGE BECAUSE THE SCHOOL DISTRICT IS REQUIRED TO NOTIFY THE DEPARTMENT OF HIGHWAY SAFETY AND MOTOR VEHICLES OF STUDENTS WHO TERMINATE SCHOOL ENROLLMENT.

STUDENT ID: _____

Print Name: _____ Date of Birth: _____
Student

_____ Date Signed: _____
Student Signature

_____ Date Signed: _____
Parent Signature

Parent Notification of Student's Declaration of Intent to Terminate School Enrollment

Name and title of person notifying parent: _____

School: _____ Date of Notification: _____

Method of notification: Conference Telephone Parent present when student withdrew

Other: _____

Students must be withdrawn from attendance using the Withdrawal Code W-05.

**Florida Department of Education
Exit Interview
(Designated School Personnel)**

To be completed by school guidance counselor or other school personnel:

School Name:	School District:
Student Name:	Withdrawal date:
Grade Level:	Student ID#:
Student DOB:	School Transcript: <i>(Please attach)</i>

What is the **primary** reason the student is terminating school enrollment (check one)

- | | |
|--------------------------|--|
| <input type="checkbox"/> | Classes not interesting |
| <input type="checkbox"/> | Marriage |
| <input type="checkbox"/> | Employment |
| <input type="checkbox"/> | Student/teacher conflict |
| <input type="checkbox"/> | Parenting |
| <input type="checkbox"/> | Suspended too often |
| <input type="checkbox"/> | Friends dropped out |
| <input type="checkbox"/> | Illness |
| <input type="checkbox"/> | Homeless |
| <input type="checkbox"/> | Failing classes |
| <input type="checkbox"/> | Migrant |
| <input type="checkbox"/> | Truancy/absenteeism |
| <input type="checkbox"/> | Did not like school |
| <input type="checkbox"/> | Expelled |
| <input type="checkbox"/> | Failed to pass Florida Required Assessment |
| <input type="checkbox"/> | Family problems |
| <input type="checkbox"/> | Intimidated/Threatened/Bullied |

Other:

Was the student in an alternative program prior to withdrawal from school? YES NO
 If no, was an alternative program available YES NO
 If yes, describe the alternative program:

Had the student received individual counseling prior to this meeting: YES NO
 If no, was counseling made available to the student? YES NO

Has a child study team been convened on the student's behalf? YES NO
 If yes, please list the interventions taken by the child study team:

Was the student involved in school sponsored extracurricular activities YES NO
 Does the student have an IEP or Section 504 Accommodation Plan YES NO
 Has the student received any remediation services in the past two (2) years? YES NO
 If yes, please describe the remediation services:

What is the average number of days the student was absent over the past two (2) years

Year 1	Year 2
--------	--------

How many unexcused absences or tardies has the student accumulated over the past two years?

Unexcused Absences:	Year 1	Year 2
Unexcused Tardies:	Year 1	Year 2

What interventions did the school attempt in response to unexcused absences or tardiness of the student while enrolled?

- Communication between the school/teacher and the family/school
- Attendance contract
- Formal meeting with the parent
- Mentoring
- Changes to the learning environment
- Referral to other agencies/services on behalf of family needs
- Student counseling
- Truancy petition
- Tutoring
- Other (please describe)

Has the student ever been suspended?	YES	NO
Has the student ever been expelled?	YES	NO
Is the student eligible for the free/reduced lunch program?	YES	NO
Does the student plan to earn a GED? If yes, inform student, for Bright Futures eligibility, GED students must complete credit requirements before taking GED exam.	YES	NO
Has the student been informed of options for continuing his/her education?	YES	NO
Has the parent been notified of the student's intent to terminate school enrollment? If yes provide the date of parent notification:	YES	NO

The student has identified the following as actions that could be taken to keep them in school

- Opportunities for real-world leaning (internships, service learning)
- Better communication with your parents
- Better teachers
- Increased parental involvement
- Smaller classes
- Less freedom and more supervision from parents
- More individualized instruction
- Less freedom and more supervision from school officials
- Better communication with your teachers

Other:

Has the student completed the student survey? _____ YES NO
 If no, how many attempts did the school make to obtain a completed survey from the student? _____

The following section is included to encourage dropout retrieval efforts.

Three (3) month follow-up: (Please check all that apply)

Method of contact:

Letter (Level 1)	Phone Call (Level II)	Home visit (Level III)
Contact successful	Contact unsuccessful	

Employment status:

Employed full-time	Employed part-time	Unemployed	Unknown
--------------------	--------------------	------------	---------

Education status:

Working on GED	Earned GED	Enrolled in another school (private/vocational)	Unknown
----------------	------------	---	---------

Other (please explain)

Did the student return to school following this contract? YES NO

Final contact (prior to start of next school year)

Not applicable: Student returned to school

Date:

Method of contact:

Letter (level I)	Phone call (level II)	Home visit (level III)
Contact successful	Contact unsuccessful	

Employment status:

Employed full-time	Employed part-time	Unemployed	Unknown
--------------------	--------------------	------------	---------

Education status:

Working on GED	Earned GED	Enrolled in another school (private/vocational)	Unknown
----------------	------------	---	---------

Other (please explain)

Did the student return to school following this contract? YES NO

School Violence: Suggested Prevention By District Safety Committee

School violence can be prevented. Research shows that prevention efforts – by teachers, administrators, parents, community members, and even students – can reduce violence and improve the overall school environment. No one factor in isolation causes school violence, so stopping school violence involves using multiple prevention strategies that address the many individual, relationship, community, and societal factors that influence the likelihood of violence. Prevention efforts should ultimately reduce risk factors and promote protective factors at these multiple levels of influence.

A. What Is a School Crime Watch?

Based on the Neighborhood Watch concept, a school crime watch helps youth watch out for each other to make the entire school area safer and more enjoyable. The school crime watch is a student-led effort that helps youth take a share of responsibility for their school community. Youth who participate in a school crime watch learn how to keep from becoming victims. They also learn the best ways to report suspicious activities or arguments between students before they turn into fights or other disturbances.

B. Planning a Successful Project

For more information on how to plan a successful project, see the National Youth Network’s Planning a Successful Crime Prevention Project. This 28-page workbook explains the five steps of the Success Cycle:

- Assessing Your Community’s Needs.
- Planning a Successful Project.
- Lining Up Resources.
- Acting on Your Plans.
- Nurturing, Monitoring, and Evaluating.

The workbook includes six worksheets for you to take notes on. You can get a copy of this planning workbook from the Juvenile Justice Clearinghouse, listed in the Resources section.

C. What Are Some Possible School Crime Watch Activities?

Student Patrol Program

A student patrol can be a powerful component of a school crime watch. These groups go beyond traffic safety patrol programs. They look for and report signs of crime and help keep crime off campuses. This moves the program from an informational and teaching posture to one of action. Patrol activities include monitoring halls and parking lots between classes and during lunch. This alone can reduce the number of crime related incidents. In schools with active patrols, crime has dropped 20 to 75 percent. Recognize, however, that if the patrol is not accepted by a majority of students, it can easily be seen as a group of “snitches.”

Anonymous Reporting System

Another school crime watch activity is setting up an anonymous reporting system. A reporting system is critical to the success of a school crime watch program. Students should report crime or incidents because they are serious issues, not because they want to get someone they don’t like into trouble. If an incident is not reported, it might escalate into a dangerous situation for the students involved. Reporting should be done on an anonymous basis, and all crime watch reports should be kept confidential. Such a reporting system can produce tips on areas to watch on the school grounds and reveal other issues of concern to students.

Crimestoppers International and Youth Crime Watch of America have worked with schools to implement these kinds of programs and can provide you with more specific information.

D. Other Activities for School Crime Watch

Student crime watch programs can perform a number of other activities to promote the overall health of the school. These include: Hosting drug- and alcohol-free parties.

- Sponsoring crime prevention fairs.
- Working with local elementary schools on child safety issues.
- Writing a column about crime prevention for your local or school newspaper.
- Presenting daily or weekly crime prevention tips over the PA system during morning announcements.
- Teaching drug prevention, personal safety, and conflict resolution to peers and younger students.
- Organizing school cleanups.

Resources –

For more information, contact one of the following organizations or visit the U.S. Department of Justice Kids Page Web site at www.usdoj.gov/kidspage. This site includes information for kids, youth, parents, and teachers.

Juvenile Justice Clearinghouse

P.O. Box 6000
Rockville, MD 20849–6000
800–638–8736
301–519–5212 (Fax)
Internet: www.ncjrs.org/ojjhome.htm

National Crime Prevention Council

1700 K Street NW., Second Floor
Washington, DC 20006–3817
202–466–6272
Internet: www.ncpc.org

Youth Crime Watch of America

9300 South Dadeland Boulevard, Suite 100
Miami, FL 33156
305–670–2409
305–670–3805 (Fax)
Internet: www.ycwa.org

National School Safety Center

4165 Thousand Oaks Boulevard
Westlake Village, CA 91362
805–373–9977
Internet: www.nsscl.org

Scholastic Crimestoppers International

Larry Wieda
4441 Prairie Trail Drive
Loveland, CO 80537
303–441–3327
303–441–4327 (Fax)
Internet: www.c-s-i.org

DRAFT

**Gadsden County School District
BULLYING AND HARASSMENT FINAL REPORT FORM**

School Personnel Completing Form:	Position:
--	------------------

Today's Date	Month	Day	Year	School:
---------------------	-------	-----	------	----------------

Name of Person Who Reported the Incident (From Reporting Form):
--

Date of Initial Report:	Telephone:	E-mail:
--------------------------------	-------------------	----------------

Student	Parent/guardian	Other (specify)
Written Report (form)	Verbal Report	Other (specify)
		Anonymous Report

Name of alleged victim:

Male/Female	Grade	Age	Race	Disabled <input type="checkbox"/> YES <input type="checkbox"/> NO	Days absent as a result of the incident:
--------------------	--------------	------------	-------------	---	---

Name(s) of alleged offender(s) (if known)	Age	School	Is he/she a student?		Days absent due to incident (include OSS)
			YES	NO	

INVESTIGATION

3. Parents/legal guardians of all involved were notified after the investigation was initiated.

Date:	Method:
--------------	----------------

4. What actions were taken to investigate this incident? (choose all that apply)

Interviewed alleged victim Date: Interviewed alleged offender(s) Date: Interviewed witnesses Date: Witness statements collected in writing Reviewed any medical information available Interviewed teacher/relevant school staff Date:	Interviewed alleged victim's parent/guardian Date: Interviewed alleged offender's parent/guardian Date: Examined physical evidence Conducted student record review (for past incidents, etc.) Obtained copy of police report Other (specify)
--	---

5. Nature of Incident: Possible reasons/alleged motives for the bullying incident (choose all that apply – be specific)

Because of race Because of national origin Because of marital status Because of gender Because of gender identity Because of religion Because of imbalance of power	Because of physical appearance To impress others Just to be mean Past conflicts Retaliation Because of another reason (specify): The reason is unknown
---	--

6.	Brief summary of incident:
7.	Where has the alleged bullying/harassment occurred:
8.	Was a clear threat involved? <input type="checkbox"/> YES <input type="checkbox"/> NO
9.	<p>Frequency and History: Did the alleged bullying occur at regular times/occasions/places? <input type="checkbox"/> YES <input type="checkbox"/> NO</p> <p>How Often?</p> <p>Have any incidents occurred in the past by the same person/people? <input type="checkbox"/> YES <input type="checkbox"/> NO</p> <p>Any past incidents from a different person/people? <input type="checkbox"/> YES <input type="checkbox"/> NO</p>

10. Effects of the bullying or harassment incident:

- Disrupted school environment and the educational process
- Physical Harm. Any possible permanent effects? YES NO
- Emotional/psychological harm or discomfort
- Absenteeism
- Damage to reputation and/or relationships
- Other (specify)

11. What corrective actions were taken in this case?

UNSUBSTANTIATED

- Parent contact
- Student conference
- Student warning
- Withdrawal of privileges
- Detention – How many days _____
- In-school suspension – How many days _____
- Counseling: Details _____
- Other: _____

SUBSTANTIATED – LEVEL III

- Parent contact
- Behavior/No Contact contract
- Suspension from bus – How many days _____
- In-school suspension – How many days _____
- Out-of-school suspension – How many days _____
- Referral to law enforcement
- Counseling: Details _____
- Other (specify) _____

12. What actions were taken in this case to protect the victim? (choose all that apply in both cases of substantiated and unsubstantiated incidents)

- | | |
|--|--|
| Safety plan in place | No contact directive |
| Monitoring situation | Additional bullying prevention education delivered |
| Schedule change | Following-up meeting in place |
| Transportation supervision | Counseling: Details _____ |
| Recommended staff the victim can go to if they feel unsafe | Other: _____ |

13. Parents/legal guardians of all involved were notified that the investigation is complete.

Date: _____ **Method** _____

14. Parents informed of the investigation outcome and the actions taken to protect the victim. Date _____

Informed: By Phone In Parent Conference By Letter

15. Additional pertinent information gained during investigation _____

(Attach a separate sheet if necessary)

16. Physical evidence collected _____

(Attach a separate sheet if necessary)

This allegation is: **Substantiated** **Unsubstantiated**

17. Entered in district discipline system: Yes No

Substantiated - BUL – Bullying or HAR – Harassment

Unsubstantiated - UBL – Unsubstantiated Bullying or UHR – Unsubstantiated Harassment

If **unsubstantiated** as bullying and/or harassment, what was the infraction? (Examples: disrespect, misconduct, altercation, intimidation/threats, verbal confrontation, unauthorized use of technology, other)

Investigator Signature: _____ Date: _____

Attach copies of supporting documentation (Bullying/Harassment Report Form, Witness Statement Form, all interview notes, and any physical evidence for your records. Send a copy of this form to Student Services)

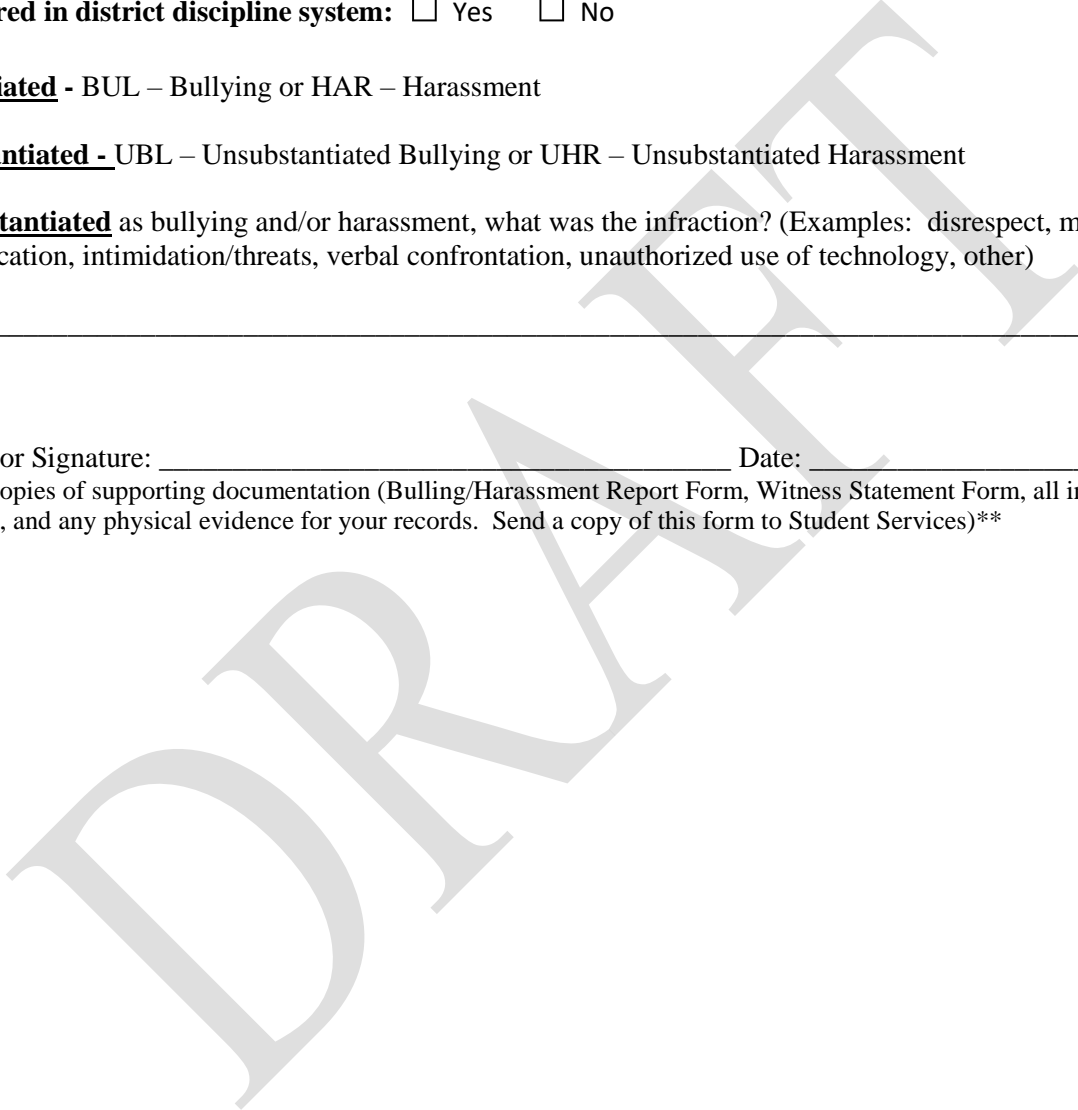

Bullying or Harassment Reporting Form (Rev. 5/13)

This form should be used to report a possible incident of bullying as defined in the Gadsden County School District's Policy Prohibiting Bullying and Harassment.

Any student can report bullying or harassment by talking to an administrator or completing this form and returning it to an assistant principal or principal. This form can be placed in the school's designated drop off spot for anonymous reporting.

PLEASE PRINT

Your name (optional): _____

School: _____

Name(s) of student(s) accused of bullying and/or harassment: _____

Is this the first time you have been bullied or harassed? Yes No
If NO, is the bullying by the same person(s) or a different person(s): Same person Different person
Were any of these incidents previously reported? Yes No To Whom: _____

Where do the incidents happen (choose all that apply)
On school property At a school sponsored activity or event off of school property On the computer
On a school bus On the way to/from school Other
On what dates did the incidents happen?

Choose the statement(s) that best describes what happened (choose all that apply)
Teasing Threat Stalking Theft Cyberbullying
Social exclusion Intimidation Physical violence Public humiliation other

What did the alleged offender(s) say or do? _____

Were there any witnesses? Yes No

Signature of student/employee completing this form (optional) Date

Thank you. This report will be followed up in a prompt manner. By completing this form, you are verifying that your statements are true and exact to the best of your knowledge. If you fear a student is in IMMEDIATE danger, please contact a trusted adult right away!

For Office Use Only

Date Received: _____

Bullying Witness Statement Form (Rev. 5/13)

This form must be completed when there is a witness to an incident of alleged bullying. One form must be completed for each witness. All witness statements that relate to one incident should be attached to the Bullying or Harassment Reporting Form.

DATE OF INTERVIEW: _____

WITNESS NAME	WITNESS TITLE (ex. Parent, Student, or Teacher)
VICTIM NAME	
ACCUSED NAME	
PRINCIPAL/SCHOOL	INCIDENT DATE

Describe the location where the incident took place:

Description of incident witnessed:

Did you take any action to intervene? Yes No
If so, what did you do?

Have you witnessed any other bullying/harassing behavior towards the victim before? Yes No

If yes, was it by the accused or someone different? Yes No

List any other witness names and grades:

I agree that all the information on this form is accurate and true to the best of my knowledge.

Signature of witness Date

Name of person interviewing witness

Bullying Complaint Report Form

This report **MUST** be completed to file a complaint relating to an incident of alleged bullying (*for the purpose of this form, bullying encompasses bullying, harassment, and discrimination*) and turned in to the school Principal/ designee of the victim’s home school or the appropriate area/district office.

PERSON FILING COMPLAINT (last, first, middle)	SEX	GRADE
VICTIM’S NAME (last, first, middle)	SEX	GRADE
ACCUSOR’S NAME (last, first, middle)	SEX	GRADE
SCHOOL SITE (or site where incident occurred)	HOME SCHOOL/DEPT. OF VICTIM	
PRINCIPAL/ADMINISTRATOR	INCIDENT DATE / /	

Describe the location where the incident took place: _____

Describe the incident: _____

List all witness names and grades: List evidence of bullying (letters, photos, etc. – attach evidence if possible):

I agree that all of the information on this form is accurate and true to the best of my knowledge.

 Signature of complainant

 Date

Be sure to attach any supporting documentation/evidence/investigation.

Action	Agreed to Informal Resolution (Student-Student only)	Formal Resolution	Appeals: Referral to Area Superintendent and/or Appropriate Area/District
Date			
Outcome			
Signatures			

Thank you. This report will be followed up within 2 school/work days.

If you fear a student is in IMMEDIATE danger, please contact the police immediately!

CLASSROOM BEHAVIOR MANAGEMENT FORM FOR MINOR OFFENSES IN K-12 SCHOOLS

STUDENT _____ I.D. _____ DATE _____
 TEACHER _____ SUBJECT _____ PERIOD _____
 CIRCLE IF APPLICABLE TO STUDENT: ESE ESOL

The above student's behavior has been disruptive to the class and inhibits my ability to teach. Specifically, the problem is:

As the classroom teacher, I have taken the following steps to correct the problem:

1st Offense: An **AFTER-CLASS DISCUSSION** was held on _____ with the student regarding the above problem. The student's reaction to the problem and my suggestions for improvement were:

_____ Favorable _____ Unfavorable _____ No reaction

Teacher Signature

Student Signature

2nd Offense: A **FORMAL TEACHER/STUDENT CONFERENCE** was held on _____ at _____.
 (DATE) (TIME)

The problem was again discussed, and the student was warned that further misbehavior would result in a referral to the office. The student's reaction to my suggestions for improvement were:

_____ Favorable _____ Unfavorable _____ No reaction

PARENT/GUARDIAN PHONE CONTACT

(Name and No.) _____ was called on _____. The parent/guardian was advised of the problems and the steps taken thus far by me to remedy the problem. The parent/guardian's support was requested. Parent/Guardian reaction was:

_____ Positive _____ Neutral _____ No reaction

3rd Offense: The following **RESOURCE PEOPLE** were consulted:

A. Department/Team Chairman/Leader: The following recommendation/s was made:

B. Guidance Counselor: The following recommendation/s was made:

C. Other: The following assistance was provided:

4th Offense: THE PROBLEM PERSISTS: I request administrative assistance with this student. [Send this form and the student to the office.]

Date/Time Student Sent

Teacher signature

White – Office Yellow – Parent/Guardian Pink – Guidance Gold – Referring Teacher

Discipline Incident Form

Gadsden County Public Schools

School

Student #	Student name	Date	Time	Officer #	Reported by	Location
-----------	--------------	------	------	-----------	-------------	----------

Incident Codes:

- AR Arson
- AS Assault, Personnel/Student
- AU Alcohol, Using/ Possession
- BA Battery, Personnel/Student
- BE Breaking & Entering/Burglary
- BU Bullying, Cyber/Physical/Verbal
- DE Defiance/Disrespectful
- ID Disruptive, Classroom/Bus
- DC Disruption on Campus/Major
- DI Driving Infraction
- DU Drugs, Use/Sale/Possession
- ED Electronic Device, School/Bus
- EX Extortion
- FI Instigating a Fight
- FO Fighting

Please check the appropriate infraction and circle the action/category if needed

- FR Failure to Report as Assigned
- HA Harassment, Physical/Sexual/Verbal
- HP Horse-playing, Campus/Bus
- II Inappropriate, Behavior/Clothing/Gesture/Language
- I2 Indecent Exposure
- LS Leaving School Grounds/Activity/Class
- OD Defacing/Destroying Property, School/Student
- SX Sexual, Act/Activity/Battery
- SG Stolen Goods, Possession
- T1 Threat, Property/Student/Personnel
- TL Theft, Personnel/School/Student
- TO Tobacco, Using/Possession
- TP Trespassing on School Campus/Activity
- VA Vandalism
- WF Weapon, Possession/Use

Detailed Information:

- A. More Serious B. Less Serious
 Drugs: M- Marijuana N- Non Controlled Substance

Incident needs to be reported to Law Enforcement: yes or no

Weapon: Description _____
 # of weapons _____
 Student in possession of weapon(s) Yes No
 Student arrested: Yes No

Comments:

Parental Contact

Parent Notification: Personal Contact Phone Message Written Communication

Name of Parent/Guardian: _____ Phone: _____

Notes:

Administrative Use Only

Administrative Disposition:

- | | | |
|--|---|--|
| <input type="checkbox"/> BR Bus Suspension | <input type="checkbox"/> DJ Placed in Time-Out | <input type="checkbox"/> DS Saturday Detention |
| <input type="checkbox"/> BS Ban from School Activities | <input type="checkbox"/> DK Require Restitution | <input type="checkbox"/> EX Recommending Expulsion |
| <input type="checkbox"/> DA Changed Assignment | <input type="checkbox"/> DN Assigned Detention | <input type="checkbox"/> IS In-School Suspension |
| <input type="checkbox"/> DG Referred to Guidance | <input type="checkbox"/> DO Work Detail | <input type="checkbox"/> LP Alternative Placement |
| <input type="checkbox"/> DH Conference w/ Student | <input type="checkbox"/> DP Parent Conference | <input type="checkbox"/> OS Suspension from School |

Number of Days: _____ Beginning Date: _____ Return Date: _____

SWD Student: If the student has received more than ten days of suspension during the current school year a manifestation meeting is required within 10 days.
 Please check, if you sent notification to the Director of Exceptional Student Education. (All suspensions requires notification.)

Comment: _____

Action by: _____ Date: _____ Time: _____ Witness: _____

Principal / Asst principal / Dean: _____

Copies: White-Parents Canary-Teacher Pink-Office Gold-Bus Driver

ATTENDANCE & SOCIAL WORK REFERRAL FORM

School _____ Referred by _____ Date _____
 Student's Name _____ Computer ID # _____
 Date of Birth _____ Age _____ Grade _____ Gender _____
 Mailing Address _____ Physical Address _____

PERSONAL INFORMATION (current only)

PARENT/GUARDIAN

Father _____ Phone (w) _____ (h) _____
 Mother _____ Phone (w) _____ (h) _____

EMERGENCY CONTACT

Name _____ Relation _____ Phone _____
 Specific directions to home (use major highway, churches, businesses, left, right, landmarks, etc.)

Mark in attendance-key: excused tardy unexcused
 Total: _____ excused _____ tardy _____ unexcused

2023

Aug	10	11	14	15	16	17	18	21	22	23	24	25	28	29	30	31							
Sept	1	5	6	7	8	11	12	13	14	15	18	19	20	21	22	25	26	27	28	29			
Oct	2	3	4	5	6	9	10	11	12	13	16	17	18	19	20	23	24	25	26	27	30	31	
Nov	1	2	3	6	7	8	9	10	13	14	15	16	17	27	28	29	30						
Dec	1	4	5	6	7	8	11	12	13	14	15	18	19	20	21	22							

2024

Jan	9	10	11	12	16	17	18	19	22	23	24	25	26	29	30	31							
Feb	1	2	5	6	7	8	9	12	13	14	15	16	20	21	22	23	26	27	28	29			
Mar	1	4	5	6	7	8	11	12	13	14	15	25	26	27	28	29							
Apr	1	2	3	4	5	8	9	10	11	12	15	16	17	18	19	22	23	24	25	26	29	30	
May	1	2	3	6	7	8	9	10	13	14	15	16	17	20	21	22	23	24					
June																							

INTERVENTIONS

(must provide written documentation)

3 unexcused (Teacher)

Date: _____

Summary of parent/child conference

5 unexcused (Guidance Counselor/Child Study Team)

Date: _____

8 unexcused (Administrator)

Date: _____

Summary: _____

8 unexcused-certified letter from school administrator (send copy of certified letter)

10 unexcused (send referral to Visiting Teacher)

Social Work Referral (state problem)

**PUBLIC NOTICES WITH PARENTAL OPT-OUT PROVISIONS
DIRECTORY INFORMATION / PHOTOGRAPHS / PUBLICATIONS**

From time to time, The Gadsden County School District photographs or videos students, and occasionally posts student-produced work online for public recognition. Local media often utilize these photographs and videos, and/or work, or come on campus with school permission to photograph or video students. Additionally, students may be videoed by school personnel for diagnostic/educational purposes. The Gadsden County School District may use these photographs, videos and work for an indefinite period of time unless the parent chooses to OPT-OUT, in writing. However, if the parent chooses to OPT-OUT, the Gadsden County School District shall not be required to recall affected work, publications, photographs, videos, and any other recorded images taken prior to the parent's OPT-OUT authorization.

If the parent does not wish photographs and/or videos of his/her child released, or does not want their child's work posted online, he/she must notify the student's school (Attn: Registrar Office), by completing this OPT-OUT form. The District will then take every reasonable effort to ensure such photographs, videos, and work will not be released. **THIS PARENTAL OPT-OUT OPTION DOES INCLUDE THE PUBLICATION OF PHOTOGRAPHS OR VIDEO TAKEN FOR THE SCHOOL YEARBOOK OR SIMILAR PUBLICATIONS.**

=====

PARENT'S OPT-OUT AUTHORIZATION

I understand that when I sign this Opt-Out form, I am instructing the Gadsden County School District not to take photographs or videos of my child and not post any of their work or post photographs/videos of their participation in school events, and the school yearbook.

Parent of Child (please print)

Student's name (please print)

Signature of Parent

Phone Number

School Name

Address of Parent/Student,
Including City and State

**GADSDEN COUNTY SCHOOL DISTRICT
LETTER OF ACKNOWLEDGMENT
and
NOTICE REGARDING CODE OF STUDENT CONDUCT
FOR SCHOOL YEAR 2023-2024**

In order to conserve resources, schools will not distribute paper copies of the *Code of Student Conduct* (Code) to every student. You can locate an electronic copy of the Code online at the District website at: www.gadsdenschools.org. **If you require a paper copy of the Code, please check the box where indicated below, sign and return this sheet, and one will be provided to your child.**

This Code has been adopted to help your son/daughter gain the greatest possible benefit from his/her education; therefore, please read and discuss the Code with your son/daughter. **To request a printed copy of the Code, please sign this sheet and return it to your child's teacher or guidance counselor.** I, as well as my child, acknowledge and will comply with the duties, responsibilities and requirements outlined in the Code of Student Conduct.

This form will be kept at the school. Training on the Code of Student Conduct will be provided to all students, teachers and administration during the first month of school.

FAILURE TO RETURN THIS REQUEST FORM WILL NOT RELIEVE A STUDENT OR THE PARENT/ GUARDIAN OF THE RESPONSIBILITY FOR COMPLIANCE WITH THE CODE OF STUDENT CONDUCT OR ACCOUNTABILITY FOR LOSS OR DAMAGE TO GADSDEN COUNTY PUBLIC SCHOOL PROPERTY.

Please check only if you require a paper copy of the 2023-2024 *Code of Student Conduct*. **One (1) copy per household will be provided.**

Please provide a paper copy of the Code

Check here

Name of your child's school

Print Student Name

Student Signature

Date

Print Parent/Guardian Name

Parent/Guardian Signature

Date

School and Teacher Printed Name

Teacher Signature

Date

FOR DISTRICT USE ONLY

A copy of the Code of Student Conduct has been printed and returned to _____ on _____. Please return this request and the paper copy of the Code to the parent/guardian of _____.

Signature of District Office Employee