



SIC Middle School

Summer
Math
Packet

Entering 7th Grade

Name: _____

Math 6 Review: Packet #1

Topic A: Prime Factorization, GCF, and LCM

Determine whether the number is prime or composite.

1. 233

2. 864

3. 597

4. 1,109

Write the prime factorization of each number.

5. 75

6. 56

7. 810

8. 1,872

Find the greatest common factor (GCF) of each set of numbers.

9. 64 and 48

10. 72 and 156

11. 45 and 108

Find the least common multiple (LCM) of each set of numbers.

12. 18 and 30

13. 24 and 40

14. 12 and 28

Indicate whether you would use a GCF or LCM to solve the problem. Then solve.

15. Kiara has 80 lollipops and 32 Snicker bars. She is filling individual bags for Halloween and would like each bag to contain the same combination of lollipops and Snicker bars. How many bags can she fill if she wishes to have no candy leftover? How many lollipops and Snicker bars are in each bag?

16. Corey is stacking 10-inch boxes while Dale is stacking 12-inch boxes. They plan to stop when their stacks are the exact same height. At what height will this be?

Topic B: Operations with Fractions and Decimals

Evaluate. Write each answer as a fraction or mixed number in simplest form.

1. $\frac{1}{4} + 4\frac{5}{6}$

2. $5\frac{1}{8} - 2\frac{1}{6}$

3. $1\frac{3}{4} + 5\frac{7}{10}$

4. $3\frac{1}{7} \cdot 2\frac{5}{6}$

5. $4\frac{1}{6} \div 1\frac{1}{4}$

6. $3\frac{2}{5} \div 4$

Evaluate.

7. $24.95 + 176.089$

8. $98.1 - 14.726$

9. $3.59(17)$

10. $80.95(0.04)$	11. $7.8(15.12)$	12. $73.2 \div 8$
13. $\frac{61.95}{15}$	14. $\frac{91.8}{3.4}$	15. $2.12 \div 2.65$

Topic C: Applications with Fraction and Decimal Operations



1. A trail that wraps around a lake is $1\frac{7}{8}$ miles long. Mara completed one lap around the lake. If she ran $\frac{4}{5}$ of the distance and walked the rest. How far did she run?	2. A piece of wire is $30\frac{2}{3}$ inches long. How many pieces of wire can be cut from this if each piece must be $1\frac{7}{9}$ inches long?
3. Nick bought $1\frac{5}{6}$ pounds of green apples and $1\frac{1}{4}$ pounds of red apples. How many total pounds of apples did he buy?	4. A taxi service charges \$1.20 per mile. If Serena paid \$16.38 for a ride to the airport, how many miles was the trip?

<p>5. Jana's six children bought her a gift for her birthday and split the total cost evenly. If the gift cost \$155.40, how much did each person pay?</p>	<p>6. If salami is on sale for \$9.68 per pound, find the total cost for 1.5 pounds.</p>
--	--

Topic D: Fractions vs. Decimals		
Write each decimal as a fraction or mixed number in simplest form.		
1. 2.8	2. 12.95	3. 7.125
Write each fraction or mixed number as a decimal.		
4. $3\frac{7}{25}$	5. $\frac{27}{40}$	6. $1\frac{5}{12}$

Topic E: Integers and Integer Operations		
<p>1. Write an integer to model each situation.</p> <p>a) a \$60 profit _____</p> <p>b) a 7-yard loss _____</p> <p>c) a 125-foot descent _____</p>	<p>2. Name the opposite of each integer.</p> <p>a) 19 _____ b) 43 _____</p> <p>c) -7 _____ d) -26 _____</p>	
Give each absolute value.		
3. $ 40 $	4. $ -17 $	5. $ 21 $ 6. $ -9 $

7. Order from least to greatest: -13, 4, -9, -17, 0, -5	8. Order from greatest to least: -46, -52, -57, -41, -60
--	---

Graph each integer at the dot on the number line. Then, number the rest of the line.	
9. 3 	10. -16 

Find each sum or difference.		
11. $-9 + (-5)$	12. $27 + (-19)$	13. $-7 + 31$
14. $8 + (-11)$	15. $6 + (-6)$	16. $-51 + 16$
17. $7 - 12$	18. $-6 - 17$	19. $14 - (-12)$
20. $-13 - 13$	21. $-8 - (-3)$	22. $-4 - (-15)$

Find each product or quotient.		
23. $7 \cdot (-4)$	24. $-9 \cdot (-8)$	25. $-2 \cdot 16$
26. $17(4)$	27. $-5(13)$	28. $-6 \cdot (-8)$
29. $-40 \div (-8)$	30. $\frac{27}{-3}$	31. $\frac{-56}{4}$
32. $56 \div 8$	33. $\frac{14}{0}$	34. $0 \div (-8)$

Topic F: Applications with Integer Operations

- | | |
|--|--|
| <p>1. The stock market ended the day on Monday at 179 points. If the market closes the following day 414 points below Monday, find the closing number on Tuesday.</p> | <p>2. Over the course of 4 plays, a football team lost 5 yards, gained 2 yards, lost 8 yards, then gained 14 yards. Find the team's total change in yards on the 4 plays.</p> |
| <p>3. A car depreciated by \$9000 in one year. Find the average change in value each month.</p> | <p>4. Sarah is hiking in a valley at an elevation of -68 feet. If she continues to descend at a rate of 8 feet per minute, find her elevation after 15 minutes.</p> |
| <p>5. A submarine is located 875 feet below sea level. If a helicopter is located 6,200 feet directly above the submarine, find the altitude of the helicopter.</p> | <p>6. A hot-air balloon is descending at a rate of 185 feet per minute. Find the change in position of the hot-air balloon after 6 minutes.</p> |

Topic G: The Coordinate Plane

Identify the ordered pair and location (quadrant or axis) for each point on the graph.

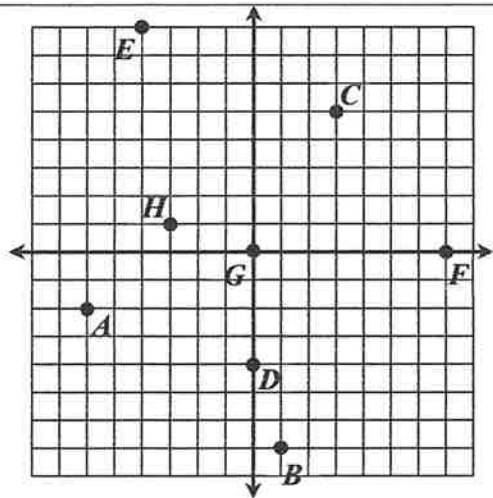

Point	Ordered Pair	Location
A		
B		
C		
D		
E		
F		
G		
H		

Name: _____

Topic A: Writing Ratios, Simplifying Ratios, Equivalent Ratios

Alexa's math grades are given in the table below. Write each ratio in simplest form in three ways.

A	
B	
C	

1. A's to B's

2. B's to total grades

3. C's to B's

List two equivalent ratios for each ratio.

4. 8:3

5. $\frac{18}{45}$

Fill in a box with a value that makes the ratios equivalent.

6. 7:3 and :12

7. $\frac{45}{36}$ and $\frac{15}{\text{input}}$

8. $\frac{24}{\text{input}}$ and $\frac{8}{18}$

Determine whether the ratios are equivalent.

9. $\frac{42}{56}$ and $\frac{6}{8}$

10. 4 to 9; 16 to 36

10. $\frac{5}{12}$ and $\frac{15}{48}$

12. To create a certain color, Mari mixes 3 drops of blue food coloring for every 5 drops of red food coloring. If she uses 18 drops of blue food coloring, how many drops of red does she need?

13. There are 56 girls and 32 boys in band. The ratio of girls to boys that play clarinet in the band is the same as the ratio of girls to boys in the entire band. If there are 7 girls that play clarinet, how many boys play clarinet?

Topic B: Ratio Tables and Graphs

Complete each ratio table.

1.

White Roses	Red Roses
5	8
	16
25	

2.

Sugar (tsp)	Calories
1	
5	80
12	

3.

Tickets	Cost (\$)
1	
2	15
6	

4. Jeremy is a car salesman. Last year, he sold two trucks for every three cars he sold. Create a ratio table and graph to show this relationship.

Trucks				
Cars				

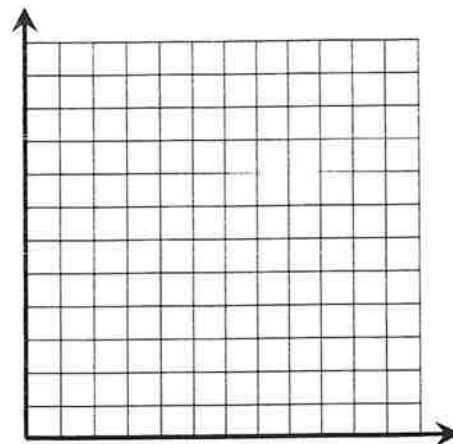

Topic C: Unit Rates; Comparing Rates

Write each rate as a unit rate.

1. 172 miles in 4 hours

2. 15 grams of fat in 6 cookies

3. 336 points in 16 games

4. If it took 27 minutes to fill a 432-gallon hot tub, find the number of gallons per minute.

5. The table below gives the amount of time, in minutes, it took three people to run a certain distance. Who ran the least minutes per mile?

	Miles	Minutes
Molly	8	52
Nathan	5	36
Darnell	12	72

Determine if Option A or Option B is the better deal. Justify your answer using unit prices.

6.

Option A: \$11 for 5 books

Unit Price: _____

Option B: \$30 for 12 books

Unit Price: _____

7.

Option A: 28 ounces of orange juice for \$3.92

Unit Price: _____

Option B: 40 ounces of orange juice for \$4.80

Unit Price: _____

Topic D: Proportional Relationships

Determine whether the quantities shown in each table or graph represent a proportional relationship. If yes, give the constant of proportionality, k .

1.

Time (h)	Earnings (\$)
2	28
3	42
5	70
9	126

2.

Time (s)	Distance (ft)
5	16
10	32
15	48
20	64

3.

Boys	Girls
2	8
5	20
12	42
16	52

4.

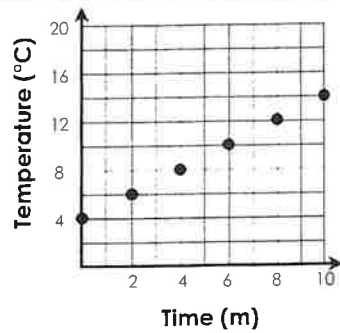

5.

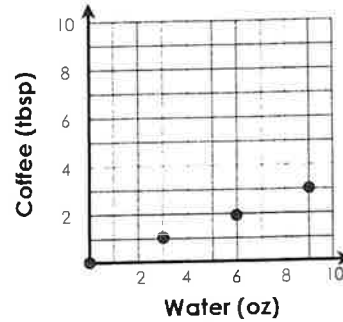

Topic E: Converting Fractions, Decimals, and Percents

Complete the chart below.

	FRACTION	DECIMAL	PERCENT
1.	$\frac{7}{25}$		
2.	$\frac{9}{5}$		
3.	$\frac{1}{8}$		
4.	$\frac{5}{12}$		
5.		0.325	
6.		2.1	
7.		0.78	
8.			87.5%

Name: _____

Topic A: Measures of Center & Range

Find the mean, median, mode(s), and range for each of the following data sets.

1. The high temperature for the past nine days: {57, 61, 57, 58, 58, 57, 61, 54, 68}	Mean:
	Median:
	Mode(s):
	Range:

2. The prices, in dollars, of six laptops: {520, 750, 700, 540, 460, 390}	Mean:
	Median:
	Mode(s):
	Range:

3. Marissa's grades on nine tests are given below. Identify the outlier, then find the measures with and without the outlier. {92, 88, 88, 92, 100, 88, 37, 98, 82}	Identify the Outlier:	
	With Outlier	Without Outlier
	Mean:	Mean:
	Median:	Median:
	Mode(s):	Mode(s):
	Range:	Range:

Determine which measure of center is most appropriate. Explain your reasoning.

4. Weights, in pounds, of 15 dogs: {55, 62, 48, 59, 74, 165, 70, 56, 82, 64, 71, 60, 53, 78, 63}

Best Center: _____ Why? _____

5. Ages of 12 players on a basketball team: {11, 10, 11, 11, 8, 11, 12, 11, 9, 10, 11, 12}

Best Center: _____ Why? _____

6. The speed of the last 10 pitches thrown by a pitcher: {90, 92, 85, 88, 94, 86, 93, 90, 88, 95}

Best Center: _____ Why? _____

7. All digital cameras in an electronics store are on sale for 20% off for the weekend. How does this affect the mean, median, mode, and range of prices of the cameras?

8. A football team has scored a different number of points in each of their first five games. If they score more points in the sixth game than any prior game, how will this affect the mean, median, mode, and range number of points per game scored?

Topic B: Dot Plots & Stem-and-Leaf Plots

The ages of the players on a hockey team are shown below.

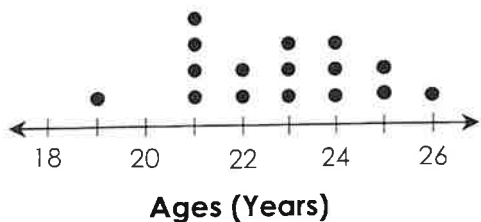

1. Compare the median and mode ages.

2. How many players are no more than 24 years old?

The time it took a group of students to complete a test is shown below.

Minutes	
Stem	Leaf
2	5 8
3	0 4 7 9
4	1 3 3 5 7
5	6

Key: 2 | 5 = 25 minutes

3. Find the mean.

4. How many students took more than 30 minutes to complete the test?

Topic C: Mean Absolute Deviation

Find the mean absolute deviation of each set of data.

1. The heights, in inches, of six people:
{62, 65, 68, 77, 71, 59}

2. The average heart rates, in beats per minute, of five people in a cycling class:
{145, 168, 156, 134, 162}

3. Two classes, Class A and Class B, took the same test. Both classes had the same mean score on the test. However, the mean absolute deviation of Class A was 10 and Class B was 2. What does this information reveal about the individual scores in each class?

Topic D: Box-and-Whisker Plots

Draw the box-and-whisker plot, then give the five-number summary, range, and interquartile range (IQR).

1. The height, in inches, of nine trees at a tree farm:
{56, 68, 45, 65, 63, 49, 75, 51, 72}



Minimum: _____
 Lower Quartile: _____
 Median: _____
 Upper Quartile: _____
 Maximum: _____
 Range: _____
 IQR: _____

2. Points scored by a football team in each of their sixteen games:
{17, 21, 25, 23, 20, 27, 16, 24, 17, 14, 21, 28, 23, 30, 14, 27}

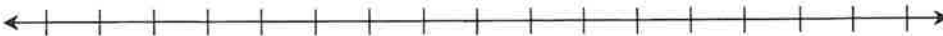

Minimum: _____
 Lower Quartile: _____
 Median: _____
 Upper Quartile: _____
 Maximum: _____
 Range: _____
 IQR: _____

Topic E: Histograms

1. Students were asked the numbers of letters in their last name. The results are shown below. Organize the data in a frequency table, then make a histogram to display the data.

**{5, 8, 9, 11, 9, 6, 7, 5, 5, 10, 8, 4, 6,
 7, 11, 4, 3, 8, 8, 5, 10, 6, 5, 8, 12}**

Interval	Frequency

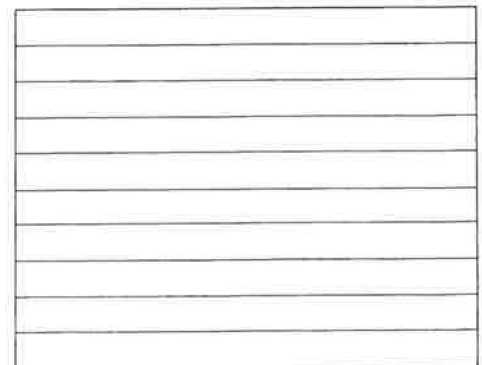

Topic G: Volume of Rectangular Prisms

Find the volume of each rectangular prism.

1.

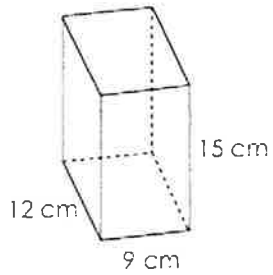

2.

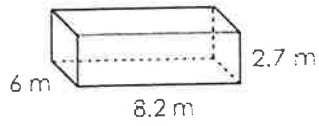

3.

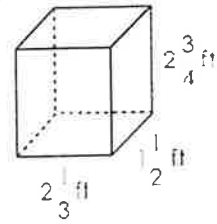

4. An inground pool is in the shape of a rectangular prism. The pool is 18 feet long by 12 feet wide with a depth of 5 feet. What is the maximum amount of water the pool can hold?

5. The bed of a dump truck in the shape of a rectangular prism is completely filled (but not overfilled) with 567 cubic feet of dirt. If the bed is 18 feet long by 7 feet wide, how deep is the bed?

Topic E: Simplifying & Factoring Expressions

Identify the variable terms, coefficients, and constants of each expression.

Expression	Variable Terms	Coefficients	Constant Terms
1. $20 + 3k - 7k + 9 + k$			
2. $11 - 4a - 3b + 5 + a + 12b$			

Simplify each expression by combining like terms.

3. $11x - 9 + 3x$	4. $19 + 3r + 5r - 7 - r$	5. $9c + 14d - 2d + 4c$
-------------------	---------------------------	-------------------------

Simplify each expression using the distributive property.

6. $3(8 + 11)$	7. $7(8 - 2)$	8. $9(k + 3)$
9. $3(2r - 7s)$	10. $5(2r + 1)$	11. $\frac{5}{4}(28c + 8)$

Topic B: Perimeter and Area of Rectangles, Parallelograms, Triangles, & Trapezoids

Find the perimeter of each figure.

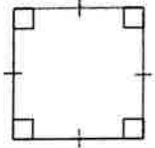
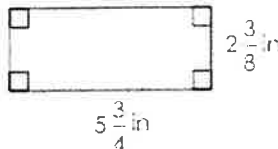
<p>1. </p> <p style="text-align: center;">9.2 mi</p>	<p>2. </p>
---	--

Find the area of each figure.

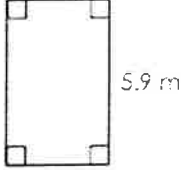
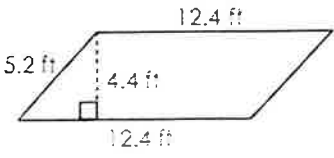
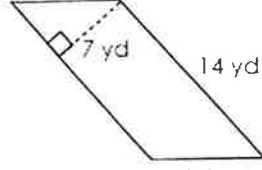
<p>3. </p>	<p>4. </p>	<p>5. </p>
---	---	---

Topic C: Evaluating Expressions

Evaluate each expression using the given variable replacements.

1. $4p - 17$

(if $p = 13$)

2. $8c - 3d$

(if $c = 2, d = 4$)

3. $2y^2 - 3y$

(if $y = 7$)

4. $\frac{4}{5}a - \frac{3}{8}b$

(if $a = \frac{5}{8}, b = \frac{2}{9}$)

5. $\frac{7y+x}{x+1}$

(if $x = 2, y = 4$)

6. $mn + n^3 \div 2m$ (if $m = 8, n = 4$)

Topic D: Translating Expressions

Translate into an algebraic expression using a variable.

1. "16 subtracted from a number"

2. "the product of a number and 9"

3. "twice a number, increased by 7"

4. "the sum of one-third of a number and 4"

Name: _____

Math 6 Review: Packet #3

Topic A: Solving One-Step Equations**Solve each equation. Check all solutions.**

1. $x + 7 = 23$

2. $42 = 6p$

3. $y - 5 = 8$

4. $\frac{a}{4} = 6$

5. $9 = 2 + m$

6. $8c = 72$

7. $11 = r - 4$

8. $\frac{k}{1.4} = 28$

9. $32.1 = 4.7 + v$

10. $x + \frac{1}{6} = \frac{13}{15}$

11. $1\frac{7}{9} = \frac{5}{6}m$

12. $c \div \frac{5}{12} = 2\frac{7}{10}$

Translate each sentence into an equation. Do not solve.

13. "The sum of 9 and a number is 4"

14. "The quotient of a number and 7 is 12."

15. "The product of a number and 3 is 42."

16. "8 less than a number is 34."