

St. John Paul II Catholic High School



Course Catalog 2024-2025

Diocese of Birmingham in Alabama



The Diocese of Birmingham in Alabama

The Most Reverend Steven J. Raica, J.C.D., Bishop
Mrs. Margaret Dubose, Director of Catholic Schools



St. John Paul II Board of Trustees

Ms. Virginia Leahy, Co-Chair
Fr. Bryan Lowe, Co-Chair
Mr. Bill Boehme
Ms. Anita Damian
Ms. Gayle Gilley
Dr. Jason Greene
Ms. Michelle Jordan
Mr. Paul Tygielski
Ms. Sharon White
Dr. Mary Ruth Yates

St. John Paul II Administration

Sr. Tonette Sperando, O.S.B., President
Dr. Jeremiah Russell, Headmaster
Mr. Lane Hill, Assistant Principal

Table of Contents

Introduction	1
Welcome Statement	1
Our Vision / Our Mission / Our Values	1
Academic Program	2-3
Graduation Requirements	2
Doubling in Math	3
Online Classes	3
Advanced Placement Course	3
Dual Enrollment	3
Theology	4-6
THL 101: Faith and Revelation (USCCB Courses I & II)	4
THL 201: The Paschal Mystery (USCCB Courses III & IV)	5
THL 301: Sacramental Theology through History (USCCB Courses V & VI)	5
THL 401: Christian Moral Living (USCCB Electives)	6
English Language Arts	7-9
Language and Introduction to Literature	7
Language and Introduction to Literature Honors	7
Language and World Literature	8
Language and World Literature Honors	8
Language and American Literature Honors	8
AP English Language and Composition	8
Language and British Literature Honors	9
AP English Literature and Composition	9
Public Speaking	9
Mythology	9
Yearbook/Journalism	9
Mathematics	10-12
Geometry	10
Geometry Honors	10
Algebra I	10
Algebra II/Trigonometry	11
Algebra II/Trigonometry Honors	11
Pre-Calculus	11
Pre-Calculus Honors	11
Calculus	11
AP Calculus (A/B)	12
Math Modeling	12
Science	13-16
Biology	13
Biology Honors	13
Chemistry	14
Chemistry Honors	14
Physics	14
Physics Honors	14
AP Physics 1	15
AP Physics 2	15
Human Anatomy and Physiology Honors	15
Environmental Science	15
AP Biology	16
AP Chemistry	16

Social Studies	17-20
World History Honors	17
US History I Honors	17
US History II Honors	17
Government Honors	18
Economics Honors	18
AP U.S. History	18
AP U.S. Government and Politics	18
AP Modern World History	19
AP European History	19
Psychology	19
Geography	19
Contemporary World Issues	20
Foreign Languages	21
Level One	21
Level Two	21
Level Three	21
Level Four	21
Spanish I Placement	21
Fine Arts	22-24
<i>Visual Arts</i>	
Art I	22
Art II	22
Art III	22
AP Art	23
<i>Performance Art</i>	
Concert Choir	23
Intro to Drama	23
Advanced Play Production	23
Film Exploration and Play Production	24
Intro to Technical Theater	24
Advanced Technical Theater	24
Band	24
Physical Education and Health	25
Beginning Kinesiology	25
Strength and Conditioning	25
Varsity Athletics	25
Health	25
Sports Medicine	25
Computer and Business Technology	26
Career Preparedness A	26
Career Preparedness B	26
Introduction to Cybersecurity	26
Other	27
Learning Strategies	27
Study Hall	27
Office Aide	27

Introduction

Welcome Statement

We extend a warm welcome to each student and family of the St. John Paul II Catholic High School community. Each family brings unique personal qualities to our school. As students, parents, and school staff, we must work together to blend these qualities into a thriving Christian community. In choosing St. John Paul II Catholic High School, you have indicated a willingness to accept and promote the values and philosophy of a Catholic school. We invite all students to take full advantage of all opportunities for personal growth as they continue to discover their individual talents.

Established in 1996, St. John Paul II Catholic High School is a Roman Catholic college preparatory school for students in grades 9-12. The school functions under the sponsorship of the Diocese of Birmingham and is a member of the National Catholic Educational Association. St. John Paul II Catholic High School is accredited as a college prep school by the Southern Association of Colleges and Schools and is a member of the Alabama High School Athletic Association.

Our Vision

St. John Paul II Catholic High School teaches as Jesus did, challenging, loving, and guiding our young people to develop their God-given gifts and talents to be academically prepared, socially responsible, humble in service to others, and active participants in the life of the Church.

Our Mission

Inspired by our patron, St. John Paul II Catholic High School develops students in spirit, mind, and body through a Christ-centered, college preparatory education. As a welcoming community of faith, we encourage, challenge, and support our students to learn enthusiastically, lead honorably, and live responsibly so they will improve themselves and society through their faith and vocation.

Our Values

Faith and Service – We practice the teachings of the Catholic Church and call each member of our community to a life of ministry and service.

Dignity and Diversity – We honor and respect individuals, embracing differences in a unified loving community.

Excellence and Quality – We promote the highest standards of achievement in our four pillars of Academics, Arts, Athletics, and Spiritual formation.

Academic Program

At St. John Paul II Catholic High School, the college-preparatory curriculum provides all students with a foundation for higher learning. Electives enable students to individualize their academic program by catering to a variety of the students' own personal interests. Our students are prepared for entry into rigorous college programs.

The St. John Paul II Catholic High School faculty consists of 44 teachers. The guidance department includes a Director of Counseling Services, a school counselor, and an interventionist. Administration includes the Headmaster, Assistant Principal, and Athletic Director. The St. John Paul II Catholic High School staff is dedicated and determined to provide the students with a quality education in a caring, Christian environment. The student/faculty ratio is 10:1.

Graduation Requirements

All students graduating must satisfy the credit requirements listed below. Students must also complete **100** hours of Community Service as a graduation requirement.

<u>Required Subjects</u>	<u>Credits</u>
Theology	4.0
English	4.0
Mathematics <i>(Algebra I, Geometry, Algebra II/Trigonometry)</i>	4.0
Science <i>(Biology, Chemistry, Physics required)</i>	4.0
Social Studies	4.0
World Languages <i>(2 consecutive years of the same language)</i>	2.0
Fine Arts	1.0
Physical Education	1.0
Electives	3.0
Health	.5
Career Preparedness A	.5
Career Preparedness B	.5
One hundred hours of Community Service	<i>no credit</i>
Total Credits Required for Graduation	28.5

Administration reserves the right to substitute and/or waive course(s) or graduation requirements due to schedule conflicts or extenuating circumstances for any transfer, International, or other students. Transfer and International students only need Theology classes for the years they attend St. John Paul II Catholic High School to meet graduation requirements.

Students Doubling in Math

Any student recommended or opting to double up in math must take a math every year they attend St. John Paul II Catholic High School. The extra math class will count toward their graduation electives. Students doubling up in math freshman year must delay Foreign Language until sophomore year.

Online Classes

See your counselor for credit recovery, credit advancement, or other online courses.

Advanced Placement (AP) Courses

AP Courses offered include:

Biology	European History
Calculus AB	U.S. Government
Chemistry	U.S. History
English-Language and Composition	World History
English-Literature and Composition	Physics 1 & 2

(Transfer students who wish to take the AP courses must have been on a college prep track and have maintained a B+ average in all related subject areas.)

Dual Enrollment

St. John Paul II Catholic High School participates in the Dual Enrollment programs at the University of Alabama in Huntsville (11 and 12 graders only), Calhoun Community College (10, 11, and 12 graders), and University of Alabama Early College (10, 11, and 12 graders). Students who enroll in any of these programs must meet UAH or Calhoun Community College Dual Enrollment or UA Early College eligibility requirements and have permission from JP II Administration and the student's counselor. Students register for classes through the college but must have forms signed off by the Counseling Department. Students should seek classes that least interferes with their JP II schedule. Senior Privilege will be a priority for students taking these classes.

While most colleges accept Dual Enrollment course credits, it is the student's responsibility to petition his/her college of choice to accept transfer credit for Dual Enrollment classes. Dual Enrollment courses receive a 0.5 credit qualifier on the student's GPA.

All courses listed in this catalog follow the standards published by the Diocese of Birmingham and incorporate the Cardinal Newman Society's Catholic Curricular Standards.

Theology

All course listings are guided by Sacred Scripture and Sacred Tradition as presented in the Catechism of the Catholic Church (CCC) following the 2008 publication by the United States Conference of Catholic Bishops: *Doctrinal Elements of a Curriculum Framework for the Development of Catechetical Materials for Young People of High School Age*.

In addition to the following core courses, “Theology of the Body” (TOB) by St. John Paul II will be interspersed throughout each grade level. TOB is the compilation of papal audience talk by John Paul II during the first five years of his papacy. TOB seeks to explain the meaning of the physical body through the themes of freedom, truth, dignity, personhood, love and sexuality; thus, revealing God’s plan for humankind.

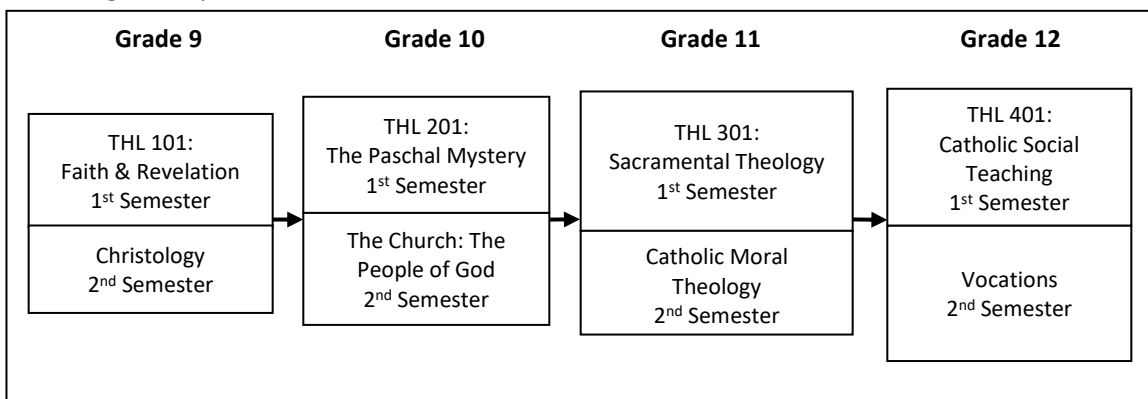

THL 101: Faith and Revelation and Christology (USCCB Courses I & II)

The course presents students with an overview of the Roman Catholic faith and Divine Revelation. Students will study the Thomistic proofs of God’s existence and learn how to use the Bible and CCC. Students will develop a religious literacy by learning key terminology from Sacred Scripture and Tradition. This course will foster a love for the Scriptures as God’s Revelation of God’s self to humanity. Through prayer, worship, and reflection, students will develop an appreciation for their unique Catholic identity.

The second part of the course introduces students to the mystery of Jesus Christ, the Living Word of God, and the Second Person of the Blessed Trinity. In this course, students will understand that Jesus Christ is the ultimate Revelation from God to us. In learning about who Jesus is, the students will also learn who Jesus calls them to be. In coming to understand the Incarnation and Christ’s Passion, students will come to know the infinite love of God and the dignity of the human person. Students will reflect upon human suffering in light of the Passion of Christ.

1 credit

THL 201: The Paschal Mystery and The Church: The People of God (USCCB Courses III & IV)

The course is for students to understand the redemptive process, set forth by God and accomplished in Jesus Christ. Students will discover that Christ's saving mission has been revealed throughout salvation history, from the origins of creation continuing through the Old Testament prophecies. In the New Testament, students will come to know and appreciate the great gift of Jesus' Incarnation, life, death, Resurrection and Ascension. Through reflections on grace, suffering and sacrifice, the implications for the life of the believer will become clear, encouraging students to accept Jesus' call to discipleship.

The second part of the course is for students to learn that the Church was founded by Christ, through the Apostles and continues to be animated and sustained by the Holy Spirit. Students will learn that various images of Church were prefigured and are rooted in Sacred Scripture and have been developed in Tradition. Rather than historical events in the life of the Church, students will come to understand the sacred nature of the Church. Reflecting on the Marks of the Church from the past, the present, and for the future, will assist students to discern the application of those "marks" to the themes of; unity, diversity, culture, universality, ecumenism, holiness, evangelization and the responsibilities of the believer.

1 credit

THL 301: Sacramental Theology and Catholic Moral Theology (USCCB Courses V & VI)

The purpose of this course is to discover the full meaning of each of the seven sacraments, including their roots in Sacred Scripture and historical evolution in the Church. Students will examine the efficacious nature of the sacraments. Students will understand that the Sacraments were initiated by Jesus Christ and with the working of the Holy Spirit; Jesus continues to act through them. Students will learn the Church is the sign and the instrument of the communion of God and God's people. Grace, healing, sanctification and Christ's presence and redemption is experienced through the seven Sacraments. In the particular study of each sacrament, students will come to know the Sacraments of Initiation, Healing and Service. As they grow in knowledge, students will come to appreciate the sacraments as sacred encounters with the Risen Christ.

The second half of this course is Catholic Moral Theology. The purpose of this course, in light of Divine Revelation and Catholic moral teaching, is to reflect on the basic moral questions: "What kind of person am I becoming? What kind of person do I want to become?" Through an examination of classical moral virtues, students will understand the importance of character formation. Students will come to know basic moral principles, Catholic moral precepts, and a method for moral decision making. In an atmosphere of respectful inquiry and research, students will apply their knowledge of Catholic morality to contemporary moral issues, enabling students to recognize the "consistent ethic of life" in the moral teachings of the Church. Students will understand that God's commandments are for human fulfillment and happiness.

1 credit

THL 401: Catholic Social Teaching and Vocations (USCCB Electives)

This course introduces students to the doctrine known as Catholic Social Teaching (CST). Students will learn the seven major themes of CST, the various types of justice as well as the concepts of peace and charity. Students will apply CST to human society for the purpose of guiding themselves and others in the mission of Jesus in the world. Students will examine the concept of social sin and the social dimension of the Commandments and the Beatitudes. Students will learn how the Scriptures and the Church's social doctrine enable them to critically examine society according to the criteria of peace and justice, thus preparing them to live as Disciples of Christ.

The second half of the course guides students to an understanding of the universal call to holiness: how Jesus Christ calls us to live. Students will study: married life, single life, priestly life, and consecrated life, understanding that each person is called to discern their vocation and how a believer serves God in the world. Students will learn from Sacred Scripture and Tradition the origins and God's plan for humanity. Students will become knowledgeable about the celebrations, effects, challenges, and the joys for each of the vocations. Students will examine the lives of the saints, seeing them as spiritual guides and role models, in order to begin to discern their own personal vocation and their call to holiness.

1 credit

English Language Arts

St. John Paul II Catholic High School requires four credits of English and places a strong emphasis on writing, reading, and critical thinking skills.

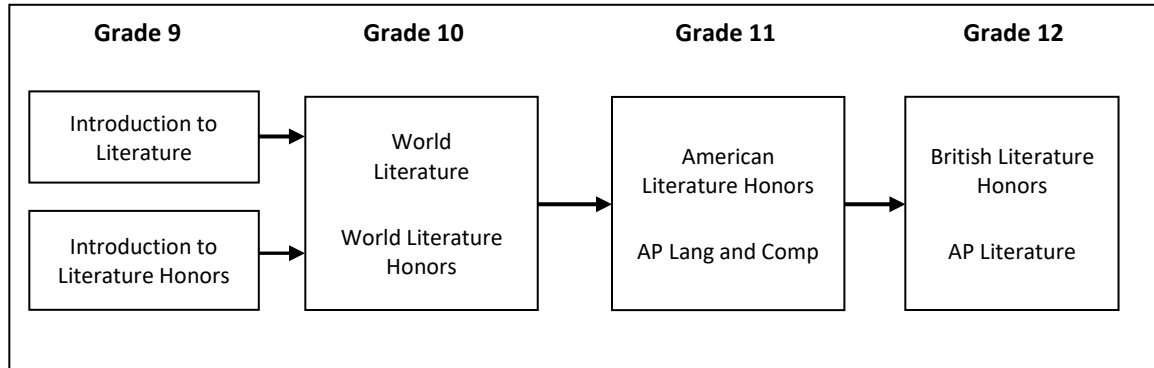

Language and Introduction to Literature

Ninth grade students will learn grammar, mechanics, MLA format, vocabulary, and composition usage skills. They will learn to write correct paragraphs, theses, and formal, academic essays. They will practice the four modes of discourse: exposition, narration, description, and persuasion. Students will practice grammar concepts, including punctuation, syntax, and correct sentence formation. They will learn to gather and synthesize research information, and they will write both brief and extensive research papers. Students will have an opportunity to develop their creative writing skills through poetry, short stories, and other genres. In literature, students will study a variety of literary themes, forms, and genres, including short story, poetry, drama, and novel. Students will read at least one book during the summer and various outside readings each semester.

1 credit

Language and Introduction to Literature Honors

Honors Ninth grade students will come to class expected to have mastered basics in grammar, mechanics, MLA format, vocabulary, and composition usage skills. They will immediately begin writing formal academic essays with thesis statements because they will have already demonstrated the ability to write well-developed paragraphs with strong topic sentences. They will practice the four modes of discourse: exposition, narration, description, and persuasion. Students will continue to practice grammar concepts, including punctuation, syntax, and correct sentence formation. They will learn to gather and synthesize research information, culminating in various research writings. Students will have an opportunity to develop their creative writing skills through poetry, short stories, and other genres. In literature, students will study a variety of literary themes, forms, and genres, including short story, poetry, drama, and novel. Students will read at least one book during the summer and various outside readings each semester.

Prerequisite: Teacher Recommendation

1 credit

Language and World Literature (1600-Present)

Tenth grade students will fortify their ability to read, write, speak, and listen effectively by studying works of literature primarily located outside America and the British Isles from the 17th century onwards, while also focusing on conventions of the English language, correct paper formatting as prescribe by the Modern Language Association (MLA), and vocabulary as a means for communication. Students will write for many different purposes, most of which fall within three categories: explanatory, persuasive, and narrative. Students will also read a variety of materials both literary and informational, discuss ideas in small- and large-group settings, and formally present perspectives and findings from research. Students will read at least one book during the summer and various outside readings each semester.

1 credit

Language and World Literature Honors (1600-Present)

Tenth grade honors students will continue developing their ability to read, write, speak, and listen effectively by studying works of literature primarily located outside America and the British Isles from the 17th century onwards, while also focusing on conventions of the English language, correct paper formatting as prescribe by the Modern Language Association (MLA), and advanced vocabulary as a means for communication. Students will write for many different purposes, most of which fall within three categories: explanatory, persuasive, and narrative; they will also read a variety of materials both literary and informational, discuss ideas in small- and large-group settings, and formally present perspectives and findings from research. Special emphasis is places on college preparedness by students' ability to comprehend, analyze, and create at an advances level without compromising conventions like editing and formatting. Students will read at least one book during the summer and various outside readings each semester.

Prerequisite: Teacher Recommendation

1 credit

Language and American Literature Honors

Eleventh grade students will continue to develop their ability to read, write, speak, and listen effectively, while also focusing on conventions of the English language, correct paper format as prescribed by the Modern Language Association (MLA), and vocabulary as a means for communication. Students will write for many different purposes, most of which fall within three categories: explanatory, persuasive, and narrative; they will also read a variety of materials both literary and informational, discuss ideas in small- and large-group settings, and formally present perspectives and findings from research. At the Honors level, special emphasis is placed on college preparedness by students' ability to comprehend, analyze, and create at an advanced level without compromising conventions like editing and formatting. Students will read at least one book during the summer and various outside readings each semester.

1 credit

AP English Language and Composition

Eleventh grade Advanced Placement students will concentrate on writing essays in various forms (narrative, exploratory, expository, and argumentative) and of increasing complexity in both style and content. These essays will be based on class readings of prose, both fiction and nonfiction, written in a variety of periods and rhetorical contexts. The readings and essay writing will prepare the students for the test in AP English Language and Composition, given in the spring. Students will read at least one book during the summer and various outside readings each semester.

Prerequisite: Must have a B+ average in English and Teacher Recommendation

1 credit

Language and British Literature Honors

Twelfth grade students will read and respond to works of British literature, from the earliest Anglo-Saxon works to the present day. These readings will be supplemented by outside sources, including essays about literature, historical background, and biographical information. Students will regularly write reports and critical essays, some requiring outside research, and will be assigned one presentation and one project. Emphasis will be placed on understanding literature in context and developing an in-depth grasp of what is read, with an expectation that independent student work and research will enrich class discussion. Students will read one book during the summer.

1 credit

AP English Literature and Composition

Twelfth grade Advanced Placement students will develop their abilities to understand and respond to works of literature through class discussions, research projects, and the writing of critical essays. The readings and essay writing will prepare the students for the test in AP Literature and Composition, given in the spring. A score of “3” or higher on this exam will allow students to exempt up to two freshman English classes at many colleges. The course is shaped around four thematically-connected units that include novels, plays, short stories, and poetry from a variety of authors, cultures, and time periods. Emphasis will be on in-depth reading and evaluation of literature for the purpose of understanding its literary elements as well as its universal themes. Students will also prepare for the AP exam by taking sample AP tests and writing representative AP essays. Students will read two books during the summer.

Prerequisite: Must have a B+ average in English and Teacher Recommendation

1 credit

Public Speaking

Students will learn the art of speaking to a variety of audiences. Course content will include interpersonal communication, intrapersonal communication, audience analysis, voice and diction, delivery, oral interpretation, speech writing, small group communication, and other requirements for effective speaking. The one-year course is designed for students from grade 9 through grade 12.

1 Elective credit

Mythology

Mythology is a semester class in which students read and discuss stories from Greece and Rome, Scandinavia, Asia, Africa, and the Americas. Emphasis will be given to identifying commonalities between these mythologies and their cultures. Students will read and discuss stories, watch and discuss videos, and create projects. All grade levels are welcome to join in becoming familiar with some of the most influential and exciting tales that have ever been told

.5 Elective credit

Yearbook/Journalism

Students learn to deal with budgets and deadlines while choosing and implementing a theme for the year’s publication of the yearbook. Students are expected to take photographs for the publication. Journalistic writing is emphasized including headlines, reporting techniques, angles, quotes and writing style. Students will also learn different aspects of advertising and marketing.

Prerequisite: Sophomores, Juniors, and Seniors only

1 Elective credit

Mathematics

St. John Paul II Catholic High School requires four credits of Mathematics.

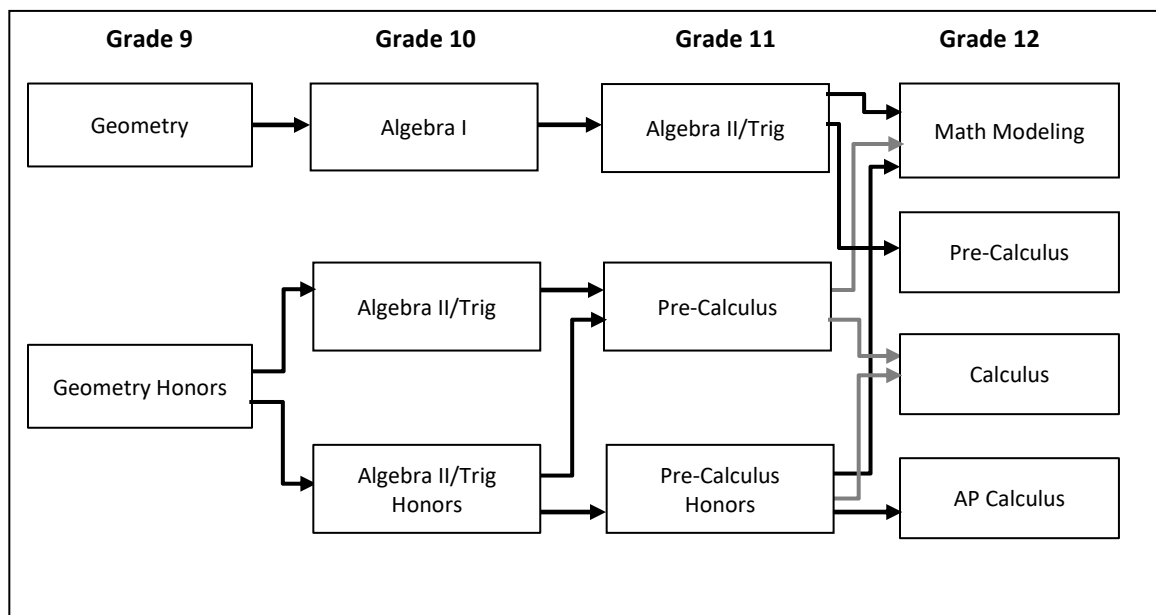

Geometry

This course introduces and develops the knowledge of plane and solid geometry: parallel lines and planes; triangles; quadrilaterals and other polygons; circles; area; volume; coordinate geometry; and basic transformations. Deductive reasoning in the form of proofs is applied throughout the course.

1 credit

Geometry Honors

This course introduces and develops the knowledge of plane and solid geometry: parallel lines and planes; triangles; quadrilaterals and other polygons; circles; area; volume; coordinate geometry; transformations; vectors; and geometric probability. A strong Algebra I background is required. Deductive reasoning in the form of proofs is applied heavily throughout the course.

Prerequisite: Recommendation of admissions review team and 8th grade math teacher. Students should already be proficient in solving systems of equations and factoring.

1 credit

Algebra I

This course introduces and develops the following knowledge areas: operations on numbers and variables; writing and solving equations and inequalities; solving systems of equations and inequalities; operations on polynomial expressions; relations, functions and graphs; variation; irrational numbers; radicals; quadratic equations and factoring; rational equations.

1 credit

Algebra II/Trigonometry

This course expands on concepts in Algebra I, adding the following areas: applications of linear equations and inequalities; matrix algebra; complex numbers; graphing and solving linear, quadratic, polynomial, absolute value, radical and rational equations and inequalities; piecewise functions; solving systems of equations; logarithmic and exponential functions; conic sections; and trigonometry.

Prerequisite: Algebra I and Geometry or Geometry Honors

1 credit

Algebra II/Trigonometry Honors

This course is designed for students who have either completed Honors Geometry or who are concurrently taking Honors Geometry. This course expands on concepts in Algebra I, adding the following areas: applications of linear equations and inequalities; matrix algebra; complex numbers; graphing and solving linear, quadratic, polynomial, absolute value, radical and rational equations and inequalities; piecewise functions; solving systems of equations; logarithmic and exponential functions; conic sections; and trigonometry. Students will be expected to apply the skills they have learned to rigorous word problems and real-world simulations throughout the year.

Prerequisites: Algebra I and Geometry Honors (or current enrollment in Geometry Honors) and recommendation of current math teacher.

1 credit

Pre-Calculus

This course is designed to prepare students for college-level Pre-calculus or Calculus. Topics include advanced algebra; analysis; analytic geometry; functions; trigonometry; vectors and parametric equations; polar coordinates; complex numbers; conics; exponential and logarithmic functions; and sequences and series.

Prerequisite: Algebra II/Trigonometry or Algebra II/Trigonometry Honors

1 credit

Pre-Calculus Honors

This course is designed to prepare students to take Calculus or AP Calculus in high school. Topics include advanced algebra; analysis; analytic geometry; functions; trigonometry; vectors and parametric equations; polar coordinates; complex numbers; conics; exponential and logarithmic functions; sequences and series; and basic first- and second-derivatives for polynomial functions. Students will be expected to apply the skills they have learned to rigorous word problems and real-world simulations throughout the year.

Prerequisite: Algebra II/Trigonometry Honors and recommendation of current math teacher.

1 credit

Calculus

This course consists of a full high school academic year of work that is comparable to a first semester College Calculus. Topics included are: functions; graphs; limits; continuity; derivatives; and integrals. Topics are approached through a combination of numerical, graphical, and theoretical exercises, and real-world activities.

Prerequisite: Pre-Calculus or Pre-Calculus Honors and recommendation of current math teacher.

1 credit

AP Calculus (A/B)

This course is an Advanced Placement course in Calculus and students are required to take the AP Calculus exam at the end of the course. This course consists of a full high school academic year of work that is comparable to a first semester College Calculus course. Topics included are: functions; graphs; limits; continuity; derivatives; and integrals. Topics are approached through a rigorous combination of numerical, graphical, and theoretical exercises, and real-world activities.

Prerequisite: Pre-Calculus Honors and recommendation of current math teacher

1 credit

Math Modeling

This course is designed for students who have successfully completed Algebra II with Trigonometry and who choose not to continue mathematics study in Pre-Calculus. Topics include: matrices; combinatorial reasoning; counting techniques; algorithms, sequences and series; and probability and statistics. Students who have completed the four mathematics requirements for graduation may take this course as an elective.

Prerequisite: Algebra II/Trigonometry

1 credit

Science

St. John Paul II Catholic High School provides full laboratory facilities. The following courses require a science fair project, and a related project report: Biology, Biology-Honors, Chemistry, Chemistry-Honors, and Physics. A school-wide science fair is held every January. The department also sponsors The American Rocketry Challenge (TARC) and other STEM teams that compete locally, regionally, and nationally. Students must complete one credit each in a Biology, Chemistry, and Physics course.

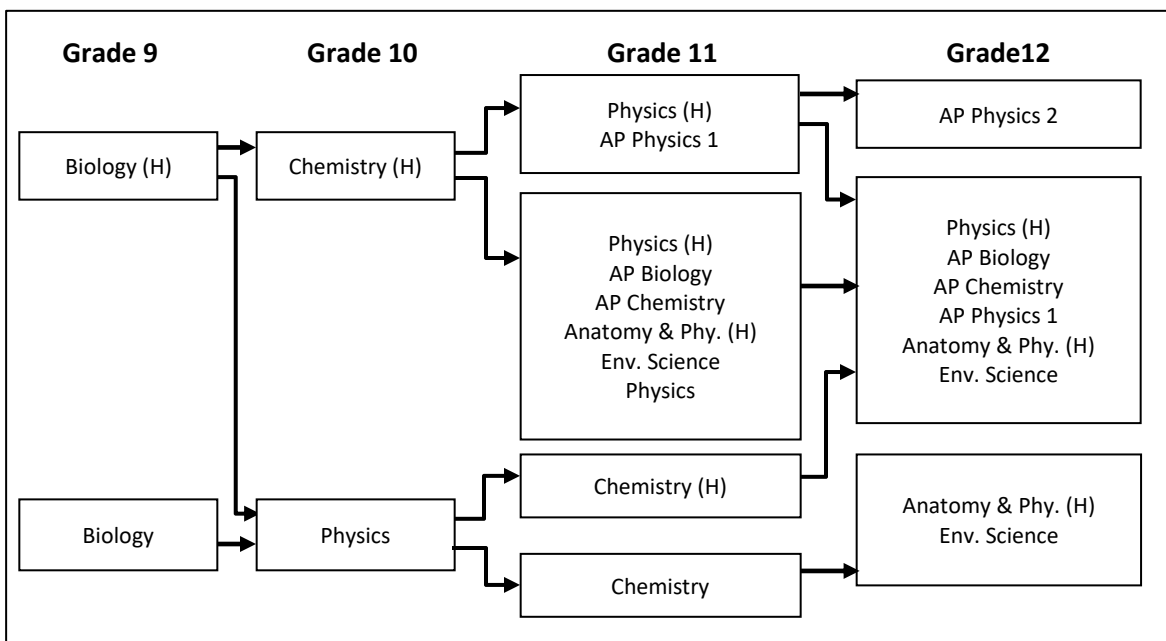

Biology

This course is a laboratory course that presents a basic introduction to biological science. Topics include biochemistry, cell biology, genetics, evolution, and the diversity of life. This course will only touch on the basics of photosynthesis, cellular respiration, and genetic engineering. Major activities include fetal pig dissection and microscopy explorations.

1 credit

Biology Honors

This course is a laboratory course that presents a basic but thorough introduction to biological science in preparation for future AP science courses. Topics include biochemistry, cell biology, genetics, evolution, and the diversity of life. This course will also include an in-depth study of photosynthesis and cellular respiration, as well as genetic engineering. Major activities include fetal pig dissection and microscopy explorations.

Prerequisites: Biology Teacher or 9th Grade Counselor recommendation

1 credit

Chemistry

This course is designed to establish a fundamental understanding of chemistry and its importance to everyday life. Emphasis is on vocabulary and the application of principal formulas and laws through labs and hands-on activities. Topics include the history of chemistry, atomic structure, periodic laws and trends, chemical bonding and reactions, basic stoichiometry, solutions, gas laws, and rudimentary thermochemistry. All students must complete a science project.

Prerequisites: Biology, Physics, Algebra II (or current enrollment) and current science teacher and guidance department recommendation

1 credit

Chemistry Honors

This course is a lab-oriented course that offers students a basic but thorough introduction to chemistry. Topics include scientific measurement, problem solving, atomic structure, the periodic table, chemical reactions, stoichiometry, behavior of liquids and gases, titrations, redox reactions, and introductory thermodynamics.

Prerequisites: Biology, Algebra II (or current enrollment)

1 credit

Physics

This course is designed to give students a basic understanding of the physical world while focusing on both physical concepts with real-life applications and problem solving. Concepts are reinforced via demonstrations, hands-on activities, and laboratory sessions. Topics include kinematics, linear mechanics, heat, optics, and waves and sound. All students must complete a science project.

Prerequisites: Biology and Sophomore or Junior standing

1 credit

Physics Honors

This course is designed to give students a basic understanding of the physical world as well as to enable students to learn problem-solving skills in both word problems and in laboratory sessions. Concepts are reinforced via a plethora of demonstrations, hands-on activities, and laboratory sessions. Topics include Fundamentals of Kinematics in one and two dimensions; Fundamentals of Linear Mechanics; Fundamentals of Work, Energy, and Power; Fundamentals of Thermal Physics and Fluid Mechanics; and Fundamentals of Electrostatics and Electric Circuits.

Prerequisites: Chemistry Honors, Algebra II

1 credit

AP Physics 1

AP Physics 1 is an algebra-based, introductory college-level physics course that explores topics such as Newtonian mechanics (including rotational motion); work, energy, and power as outlined by the AP College Board. This course requires that 25 percent of the instruction time be spent in hands-on laboratory work, with an emphasis on inquiry-based investigations that provide students with opportunities to apply the science practices. This is a two-period course. Laboratories will be performed weekly to satisfy the 25 percent minimum classroom requirement. Both instructor-led and inquiry-based (student-led) laboratories will be conducted throughout the year. Lectures will be balanced with recitation for in-depth homework solutions and discussions. Completion of the AP Physics 1 exam is required.

Prerequisites: Chemistry Honors, Pre-Calculus Honors (or current enrollment) and recommendations from current science and math teachers

2 credits

AP Physics 2

AP Physics 2 is an algebra-based, introductory college-level physics course that explores topics such as Electrostatics, Electric circuits, Magnetic fields, Electro-Magnetism, Fluid Mechanics and Thermal Physics; Wave motion and Optics; and Nuclear and Atomic Physics as outlined by College Board. This course requires that 25 percent of the instruction time be spent in hands-on laboratory work, with an emphasis on inquiry-based investigations that provide students with opportunities to apply the science practices. This is a two-period course. Laboratories will be performed weekly to satisfy the 25 percent minimum classroom requirement. Both instructor-led and inquiry-based (student-led) laboratories will be conducted throughout the year. Lectures will be balanced with recitation for in-depth homework solutions and discussions. Completion of the AP Physics 2 exam is required.

Prerequisites: Honors Physics or AP Physics 1 and AP Calculus or Calculus (or current enrollment) and recommendations from current science and math teachers

2 credits

Human Anatomy and Physiology Honors

This course gives students with an interest in health-related topics and careers an opportunity to study in-depth the structure and functions of the major human body systems. The major body systems explored include the integumentary, skeletal, muscular, nervous, cardiovascular, respiratory, digestive, and urinary systems.

Prerequisites: Biology and Chemistry

1 credit

Environmental Science

This course gives students a fundamental understanding of environmental science and its importance to everyday life. This course involves the study of the interrelationships of organisms with their environment, promotes awareness and an appreciation for the environment, and promotes an understanding of the factors that affect the environment, including energy sources and pollution.

Prerequisites: Biology and Chemistry (or current enrollment); Junior or Senior standing

1 credit

AP Biology

This two-period course is a college-level biology course, with a comprehensive emphasis on biochemical processes and the study of all living things in preparation for the AP exam. AP Biology includes an advanced laboratory program in which most of the College Board-designated AP labs are completed. Topics include biochemistry, cell biology, genetics, evolution, botany, ecology, and animal form and function. The second period is utilized for laboratory experiences, regular coursework, and independent study halls.

Prerequisites: Biology Honors, Chemistry Honors and current science teacher approval

1.5 credits

AP Chemistry

This two-period course is a college-level chemistry course designed to enable students to attain a depth of understanding of the fundamentals of chemistry. AP Chemistry includes a comprehensive set of laboratory experiences. Topics include structure of matter, states of matter, nuclear chemistry, reaction types, stoichiometry, chemical equilibrium, kinetics, and thermodynamics. The second period is utilized for both laboratory experiences and further instruction.

Prerequisites: Chemistry Honors and current science teacher recommendation

2 credits

Social Sciences

St. John Paul II Catholic High School requires four credits of Social Studies. The course of study emphasizes the understanding of ideas and values that lay the foundation for responsible citizenship, while fostering the development of analytical and critical thinking through the study of history, geography, economics, and political science.

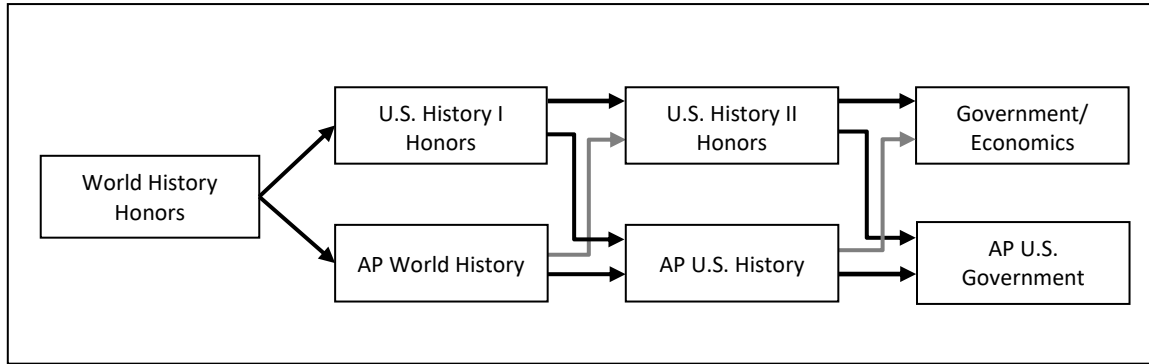

World History Honors

This course introduces students to the study of world history since the mid-14th century. Students will explore topics including the European Renaissance, Industrialization, Imperialism, World Wars, post-colonialism, and globalization. Students will have opportunities to survey and investigate significant events and ideas which contributed to our modern world, as well as sharpening analytical, critical thinking, and research skills.

1 credit

U.S. History I Honors

This course engages students in the study of United States history from the Colonial era to Reconstruction. Students will have opportunities to survey and investigate significant events and ideas in the development of the United States, as well as explore its role in world affairs, while sharpening analytical, critical thinking, and research skills.

Prerequisite: World History Honors

1 credit

U.S. History II Honors

This course engages students in the study of United States history from Reconstruction to the present day. Students will have opportunities to survey and investigate significant events and ideas in the development of the United States, as well as explore its role in world affairs, while sharpening analytical, critical thinking, and research skills.

Prerequisite: U.S. History I Honors

1 credit

Government Honors

This one semester civics course for twelfth grade students gives a broad overview of the policies and institutions of the United States government. While becoming knowledgeable about the foundations, the structures, and the theories underpinning the United States' system of government, students will also gain an understanding of how a democratic republic functions, including their own role as active and informed citizens.

Prerequisites: U.S. History II Honors, AP U.S. History

.5 credit

Economics Honors

This one semester social science course for twelfth grade students provides students with an introduction to the basic characteristics of the American economic system. It covers the economic principles that influence business decisions and the role of government and individuals in the economy. The curriculum incorporates the study of healthy personal finance practices.

Prerequisites: U.S. History II Honors, AP U.S. History

.5 credit

AP United States History

This college-level course, taken primarily by eleventh grade students, examines the evolution of the political, economic, diplomatic, social, and cultural history of the United States from the Colonial era to present day. This course engages students in the comprehensive study of critical issues and events of American history. Students will engage in college-level assignments which focus on analytical and evaluative writing, historical research, Document-Based Questions, comparative analysis, thematic categorization, and primary and secondary source synthesis. For AP recommendation, students should be in Honors English with a minimum overall grade of 89. Students must demonstrate the requirement from Honors English of writing formal academic essays with thesis statements because they will have already demonstrated the ability to write well-developed paragraphs with strong topic sentences. Any student in Regular English should demonstrate a thesis essay to the AP teacher to review before approval into the AP class. This college course is equivalent to two three-hour United States History courses. Only students who score well on the AP Exam in May and choose a university which accepts AP credit can receive college credit for this course.

Prerequisite: AP World History or U.S. History I and teacher recommendation

1 credit

AP U.S. Government and Politics

This college-level political science course, taken primarily by twelfth grade students, is a yearlong course of study. Students are introduced to the discipline of political science while also acquiring an in-depth understanding of the American system of government and its political processes, from its foundations to the present day. This college course is equivalent to a three-hour college political science course. Only students who score well on the AP Exam in May and choose a university which accepts AP credit can receive college credit for this course.

Prerequisite: AP U.S. History or U.S. History II Honors and teacher recommendation

1 credit

AP Modern World History

This course introduces students to the study of world history since the mid-13th century and foundations of religion and philosophies. Students will explore topics including the European Renaissance, Chinese Dynasties, Industrialization, Imperialism, World Wars, post-colonialism, and globalization. Students will engage in college-level assignments which focus on analytical and argumentative writing, historical research, Document-Based Questions, comparative analysis, thematic categorization, and primary and secondary source analysis. This college course is equivalent to a three-hour Western Civilization course. Only students who score well on the AP Exam in May and choose a university which accepts AP credit can receive college credit for this course.

Prerequisite: Teacher recommendation

1 credit

AP European History

This is an elective college-level course that engages students in an in-depth study of key events in European history from the Renaissance to the present. It offers a comprehensive overview of the development of European culture, while also introducing students to the concerns, resources, and methodologies of historical studies. Students will engage in college-level assignments which focus on analytical and evaluative writing, historical research, Document-Based Questions, comparative analysis, thematic categorization, and primary and secondary source synthesis. This course is designed for students who want to benefit from positive peer interactions in a topic of similar interest. This college course is equivalent to a three-hour college Western Civilization course. Only students who score well on the AP Exam in May and choose a university which accepts AP credit can receive college credit for this course.

Prerequisite: US History 1, Juniors and Seniors

1 credit

Psychology

This yearlong social science course presents an overview of the science of the mind. Students will engage in activities focusing on personality theories and developmental psychology. Students will also explore topics such as personality disorders and treatment.

Prerequisite: Sophomores, Juniors and Seniors

1 Elective credit

Geography

This one semester social science course engages students in the study of the physical environment and human population of our planet Earth. Students will participate in multiple activities to learn about the 196 countries in our world. Students will also have opportunities to locate landforms, nations, and cities using latitude and longitude, study Earth's biomes and climates and their impact on the human population, discuss the impact of typical and extreme weather patterns on both the environment and humans, and analyze the causes and effects of deforestation, salinization, agriculture, and other environmentally altering human actions. Students will use a framework of Church Doctrines and Biblical teachings to discuss God's calling for humans to be good stewards of the Earth. Additionally, throughout the semester, students will research the Earth's physical environment both historically and currently.

Prerequisite: Sophomores, Juniors, and Seniors

.5 Elective credit

Contemporary World Issues

Students analyze governments, economies, peoples, and cultures from around the world in this course. Instruction emphasizes the structures and policies of the United States and how they compare to other systems in the international community. Students apply critical thinking and research skills to examine current events and contemporary issues facing the United States and the world.

Prerequisite: Juniors and Seniors Only

.5 Elective credit

Foreign Languages

St. John Paul II Catholic High School offers three foreign languages: French, Spanish, and Latin. Latin will place emphasis on primary source translation instead of conversational skills. Additional language classes may be available through our Dual Enrollment program with UAH and Calhoun. Students must complete two years of the same foreign language for graduation requirements.

Level One (French, Spanish, and Latin)

The language is introduced through a proficiency-based program that helps the student to develop the skills of listening, speaking, reading, and writing. Cultural themes and basic conversational patterns are taught.

1 credit

Level Two (French, Spanish, and Latin)

Material from the first level is reviewed and a more detailed study of vocabulary and grammar is included. More complex structures of the language along with the intermediate conversational skills are presented and cultural themes of the first level are expanded.

Prerequisite: Level One or Passed Proficiency Test

1 credit

Level Three (French, Spanish, and Latin)

More advanced conversational skills are emphasized. The finer points of grammar are given due attention. Translation skills are developed. Significant historical figures, authors and the literature of the target language are studied.

Prerequisite: Level Two of same foreign language

1 credit

Level Four (French, Spanish and Latin)

Continuance of skills emphasized in level three with emphasis on history, music, art, literature and refinement of grammatical structures.

Prerequisite: Level Three of the same foreign language

1 credit

Spanish I Placement

Some of our incoming 9th graders have a strong background in Spanish and would like to begin their studies in level II of the language. Students may take a Spanish I proficiency test which covers the material taught in a Spanish I course. A student that successfully completes the Spanish I test may begin with Spanish II and will then take Spanish III in the 10th grade.

Please note: This test directly correlates to requirements in the Alabama course of study for Spanish I. Portions of this test are not part of or required to be a part of any middle school curriculum.

Fine Arts

St. John Paul II Catholic High School offers fine Arts Courses in the Visual Arts and in the Performing Arts.

Visual Arts

St John Paul II Catholic High School offers a four-year curriculum in visual art (Art I – Art IV). Student art at all four levels is exhibited locally and regionally in competitions and shows. Assignments build sequentially in technical difficulty and in complexity. Therefore, students must have Art I (or its equivalent) before taking Art II, etc. If transferring from another high school, students are encouraged to bring examples of their previous artwork for proper placement.

Art I / Beginning Art

This art course serves as a base for further art courses. The primary focus during this period is to help students build a strong foundation in comprehending the principles and elements of art and design. Though students will get to experiment with various mediums. The course is structured to emphasize the development of their skills in design, drawing, and vocabulary.

Fee: \$75.00

1 credit

Art II / Intermediate Art

Building upon Art 1 skills, this class aims to provide a strong foundation for advanced Art courses. Specifically, it is a drawing course that focuses on the techniques of line, form, shading and composition. Participants will undertake a series of progressively challenging projects that will help them refine their drawing skills and gain confidence in their ability to represent the world around them. The overall goal of the course is to instill a strong foundation for future artistic endeavors.

Prerequisite: Art I and Teacher Approval/Fee: \$100

1 credit

Art III / Advanced Art

Advanced Art is a course designed for students who have successfully completed Art I, Art II, or have equivalent experience. This course focuses on encouraging students to explore more complex and personalized drawing projects while developing their unique artistic voice. Students will experiment with various mediums, cultivate their own personal style, and engage in thematic projects that encourage critical thinking and creative problem-solving. The course is designed to be an accelerated approach for students who have a strong foundation in drawing and mixed media and who are ready to move into painting during the second semester. Throughout the course, students will produce a body of work for their portfolios that will compete for recognition and awards at the statewide and national levels.

Prerequisite: Art I, Art II AND Teacher Approval/ Fee: \$100

1 credit

Advanced Placement Studio Art Drawing

AP Drawing is an advanced placement course designed to prepare students for the rigors of a college-level art education. Students will focus on building a portfolio for submission to the College Board's AP Drawing Exam. The course challenges students to create a sustained investigation of a specific theme or concept, showcasing a high level of technical skill, artistic vision, and conceptual depth. Students will engage in regular critiques, discussions of art theory, and preparation for the AP Exam. AP. Students will demonstrate a strong knowledge of visual elements and principles of design through a broad interpretation of drawing issues and media which will include skills such as: line quality, light, rendering, composition, surface manipulation, and mark making. Media may include drawing, painting, printmaking, and mixed media. AP Studio Art is a portfolio-based course. Participation in the national AP test is a mandatory component in the rigor of this course.

Prerequisite: Art III, Approval of Instructor / Fee: \$100

1 credit

Performing Arts

Concert Choir

Vocal music class provides training in proper vocal technique and studies in music theory, sight-reading, and exposure to a vast array of choral literature. The ensemble performs at three major concerts: the Sacred Arts Concert, Christmas Concert, and the Spring Concert; as well as the Veterans Day program, State Choral Performance Assessment (SCPA) and graduation. The group also sings at such events as school liturgies and concerts at area schools. In addition, students have many optional opportunities to perform including the Alabama All-State Chorus, Madison County Honor Choir, Alabama Honor Choir, and Solo/Ensemble Festival. The choir also participates in a Regional Choral Festival each spring. Past regional festivals have been to New Orleans, Gatlinburg, Cincinnati, Atlanta, and New York.

1 credit

Introduction to Drama

This course offers study in many aspects of theater, including stage movement, pantomime, voice and diction, theater history, improvisation, script analysis, playwriting, scenic design, and marketing. The course culminates in a final project utilizing the skills learned throughout the year. Prerequisite for Advanced Play Production.

1 credit

Advanced Play Production

This course will provide the student with practical experience in the production of a dramatic presentation with assignments in acting and stage management. It will also include the study of style/movement, and the study of voice for the performer. The class will rehearse and perform a play and a musical.

Prerequisite: Intro to Drama / Fee: \$150

1 credit

Film Exploration and Production

In the first quarter of this film appreciation class, the student will master the art of camera movement, camera angles, editing, producing, and acting; culminating in the creation of several short films. Students will learn the vocabulary of film cinematography, movement, sound, writing, and acting, and will analyze these elements in representative films. The course will also include a unit on film history.

Prerequisite: Sophomores, Juniors, and Seniors only

1 credit

Introduction to Technical Theater

This course focuses on beginner techniques that are the foundation for technical theater. The class will provide the student with slow, extensive, and practical experience in the design and production of a dramatic presentation with assignments in scenery, lighting, properties, sound, costumes, make-up, publicity, and other aspects of theatre production. The class may be taken more than once and may be taken for one semester or as a yearlong course. Students will be required to attend and participate in some technical work, rehearsals, and/or performances, beyond the school day, to support, extend, and assess learning in the classroom. It is a prerequisite for Advanced Technical Theater.

1 credit

Advanced Technical Theater

This course focuses on advanced techniques that are the foundation for technical theater. The class will provide the student with fast paced, practical experience in the design and production of a dramatic presentation with assignments in scenery, lighting, properties, sound, costumes, make-up publicity, and other aspects of theatre production. The class may be taken more than once and may be taken for one semester or as a yearlong course. Students will be required to attend and participate in some technical work, rehearsals, and/or performances, beyond the school day, to support, extend, and assess learning in the classroom.

Prerequisite: Intro to Technical Theater

1 credit

Band

Band consists of concert, marching, and pep bands. The concert band performs in at least five major programs per year: Sacred Arts Concert, Veterans Day Program, Christmas Concert, Spring Concert, and JP II Graduation. The marching band holds a band camp every summer in late July and performs at JP II football games, marching exhibitions and competitions, and community events. The band also performs at school functions such as pep rallies and other events as requested by the JP II administration. All members of the JP II band participate in concert, marching, and pep bands. **Fee: \$175**

1 credit

Physical Education and Health

Beginning Kinesiology

Beginning Kinesiology is the physical education course required for graduation. It is a stand-alone course which encompasses the basic concepts of athletics and fitness, and introduces students to the basic physiological, psychological, sociological, and mechanical principles of human movement. Students will be empowered to make choices, meet challenges, and develop positive behaviors in fitness, wellness, and movement activity for a lifetime. It is highly recommended that students take Beginning Kinesiology in grade 9.

1 credit

Strength and Conditioning

The Strength and Conditioning course for JPII student athletes and is designed to provide a comprehensive understanding of exercise science principles and practical applications in the context of strength training and conditioning. Through a combination of instruction, hands-on training, and fitness assessments, students will develop the knowledge, skills, and habits necessary to enhance their physical fitness, athletic performance, and overall health. This course is not a substitute for Beginning Kinesiology.

Prerequisite: Head Coach's recommendation

1 Elective credit

Varsity Athletics

Varsity Athletics is a yearlong restricted elective course only for high school athletes. This course offers development of skills and personal potential for student athletes interested in improving their performance or preparing for further competition at the collegiate or professional level. The standards address more than the sport itself. Coaches will assist athletes with learning and achieving higher levels of performance and physical literacy.

Prerequisite: Current member of an athletic team and recommendation from appropriate Head Coach.

1 Elective credit

Health

This is a required course which is only one semester in length. The students will learn the five dimensions of wellness and how they relate to each other. They will evaluate their own health knowledge and behavior and develop strategies for reducing risk factors.

.5 credit

Sports Medicine

The Sports Medicine class would be beneficial to anyone who would be considering a career in the medical field. This course will cover administration and development aspects of an athletic trainer, anatomy and physiology, prevention and treatment of injuries, as well as the rehabilitation of injuries. There is a hands-on section involving in class and out of class experiences. The class is a yearlong elective class.

1 Elective credit

Computer and Business Technology

St. John Paul II Catholic School requires two Computer and Business Technology courses for graduation: Career Preparedness A and Career Preparedness B. Introduction to Cybersecurity is an elective Computer and Business Technology course.

Career Preparedness A

This course will cover personal decision making, academic planning, career development, and personal skills assessment. It will also cover basic and advanced technology concepts including diagnosing problems, file manipulation, operating systems, emerging technologies, digital citizenship, collaborative learning, and ethics.

.5 credit

Career Preparedness B

This course will prepare students with the 21st Century skills needed to win with money now and for the rest of their lives. It will focus on personal finance concepts including budgeting basics, saving money, credit and debt, consumer awareness, career readiness, college planning, financial services, housing and real estate, investing and retirement, the role of insurance, and income and taxes.

.5 credit

Introduction to Cybersecurity

RING (Regions Investing in the Next Generation) is a high school cybersecurity course that introduces students to basic cybersecurity concepts. The course aims to mentor students down their career path as an IT professional, instilling ethics and pride in the profession along the way. It includes hand-on labs and activities that cover topics such as computer hardware, networking, computer forensics, cybersecurity law, and cryptography. A short introduction to Python programming language is included.

1 Elective credit

Other

Learning Strategies

Learning Strategies is a course intended to support and prepare JPII students for success both academically and socially. The material is rooted in motivation, growth-mindset, and resilience. As students are introduced to study skills and learning methods, they are continually asked to apply the concepts in reading, writing, and thinking exercises, which build a solid base for classroom discussion and success in their core classes. Students engage in self-analysis and research-based strategies to identify their strengths, challenges, and aptitudes.

.5 Elective credit

Study Hall

This course is to provide time for students to complete homework, assignments, organize class material, and prepare for tests. Students are expected to be on task with school work at all times. Students who do not use their time as required may be removed from Study Hall and placed in another elective class. ***No credit is awarded for Study Hall***

Prerequisite: Sophomore, Junior, or Senior

Office Aide (semester)

This course is only for those students who have excellent academic, disciplinary, and attendance records. They will be required to perform tasks for the office staff that include running errands, answering phones and directing calls, answering student, parent, and visitor questions, and assisting new students with lockers and classes. Students who take Office Aide both semesters will receive .5 Elective credit.

Prerequisite: Sophomore, Junior, or Senior

.25 Elective credit