

MODULAR BUILDING FOR FURLOW CHARTER SCHOOL

SITE PLAN

63 VALLEY DRIVE
PART OF LAND LOT X
27th LAND DISTRICT
AMERICUS, SUMTER COUNTY, GEORGIA

NOVEMBER 28, 2022

INDEX TO DRAWINGS

CIVIL

SHEET NO.	TITLE
C1.0	INDEX SHEET
C2.0	PROJECT NOTES
C3.0	TOPOGRAPHIC SURVEY
C4.0	SITE PLAN
C5.0	UTILITY PLAN
C6.0	CONSTRUCTION DETAILS

GPS COORDINATES:

32.046875, -84.229089

INDEX SHEET

SCALE: NONE

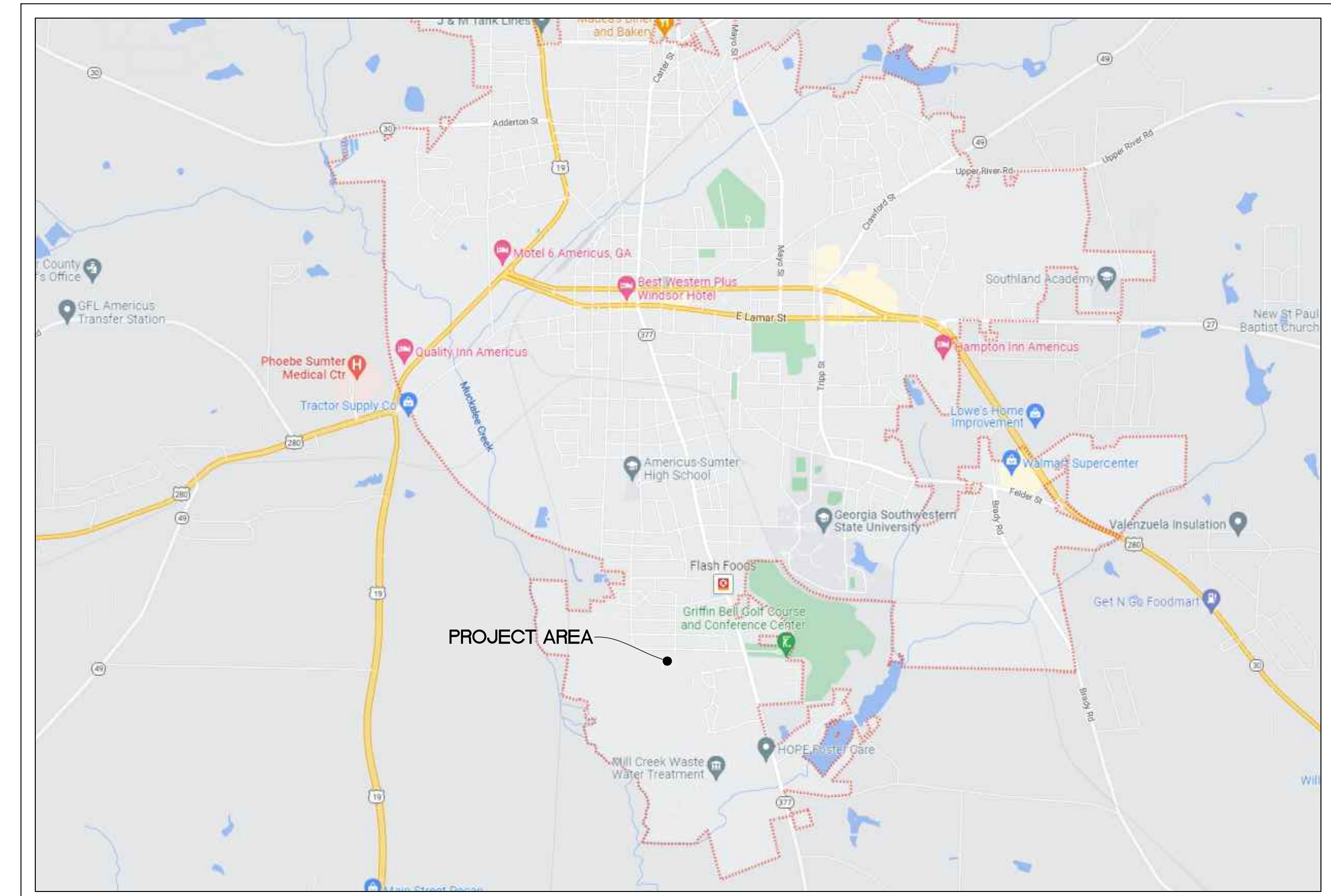

LOCATION MAP



VICINITY MAP

ENGINEER



Threadcraft Engineering, Inc.

1021 HADLEY MEADOWS DRIVE
RALEIGH, NORTH CAROLINA
(919) 600-8399
www.tei-engineers.com

ENGINEER



P.O. 7290
TIFTON, GEORGIA 31793
(229) 382-1700
www.harrelljacksoninc.com

OWNER



63 VALLEY DRIVE
AMERICUS, GEORGIA 31709
(229) 931-8667

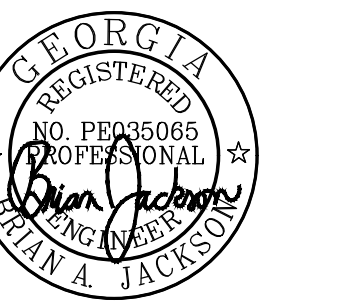

REVISIONS	
1	01/04/23
2	
3	
4	
5	
6	
7	
8	

PROJECT:
**MODULAR BUILDING FOR
FURLOW CHARTER SCHOOL**

PART OF LAND LOT X
27th LAND DISTRICT
AMERICUS, SUMTER COUNTY, GEORGIA
DATE: NOVEMBER 28, 2022

JN: 22023

SHEET NUMBER

C1.0

1 OF 6

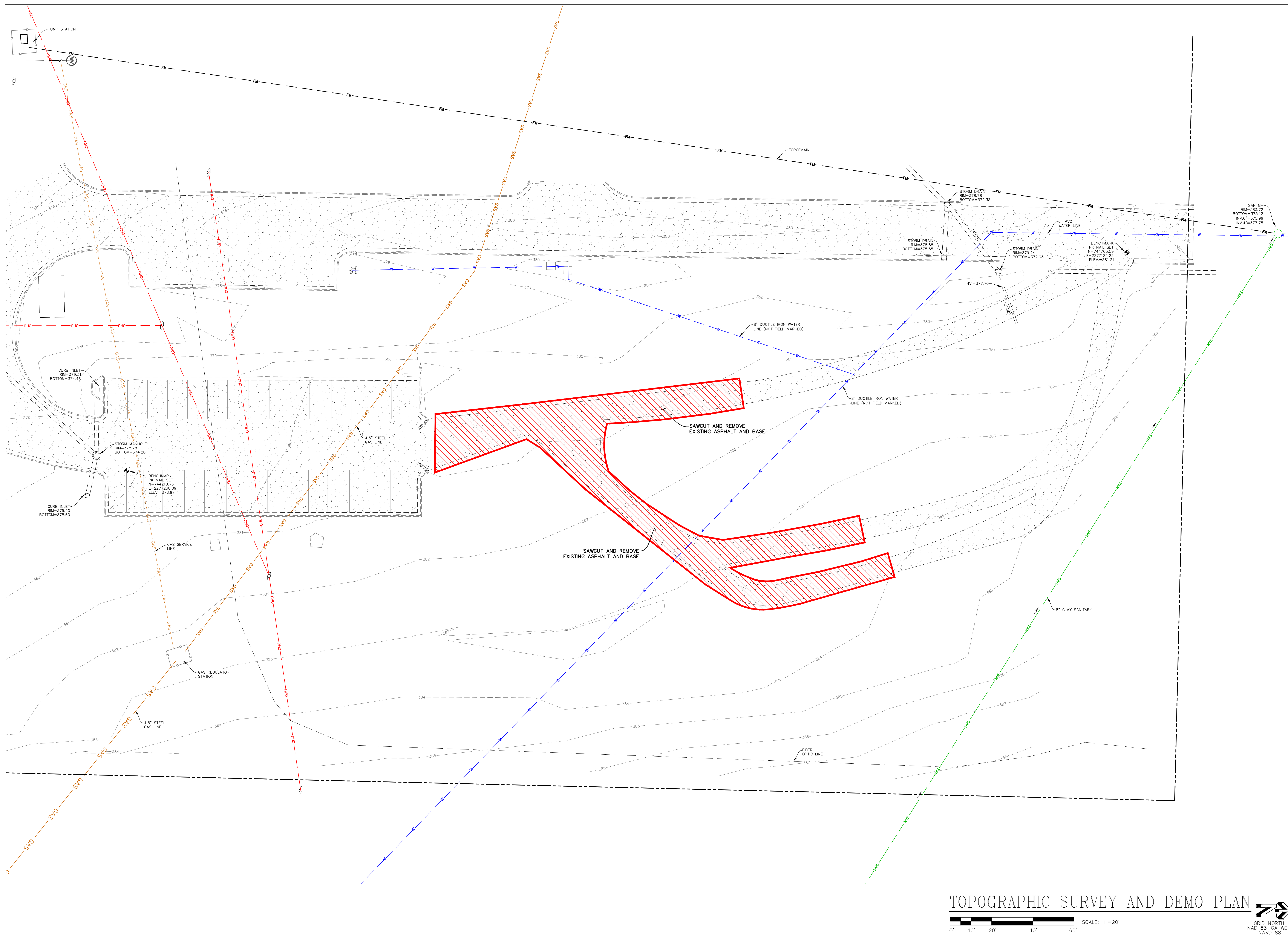

ENGINEER



1021 HADLEY MEADOWS DRIVE
RALEIGH, NORTH CAROLINA
(919) 600-8399
www.tei-engineers.com

ENGINEER



P.O. 7290
TIFTON, GEORGIA 31793
(229) 382-1700
www.harrelljacksoninc.com

OWNER



63 VALLEY DRIVE
AMERICUS, GEORGIA 31709
(229) 931-8667

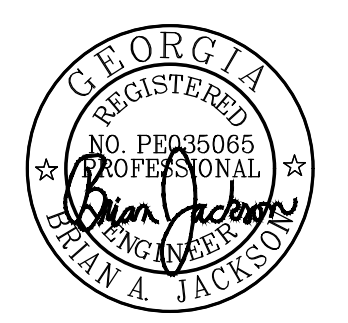

REVISIONS	
1	
2	
3	
4	
5	
6	
7	
8	

PROJECT:
**MODULAR BUILDING FOR
FURLOW CHARTER SCHOOL**

PART OF LAND LOT X
27th LAND DISTRICT
AMERICUS, SUMNER COUNTY, GEORGIA
DATE: NOVEMBER 28, 2022

JN: 22023
SHEET NUMBER
C3.0

TOPOGRAPHIC SURVEY AND DEMO PLAN

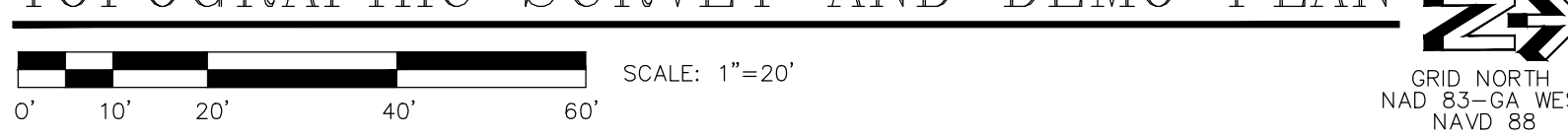

3 OF 6

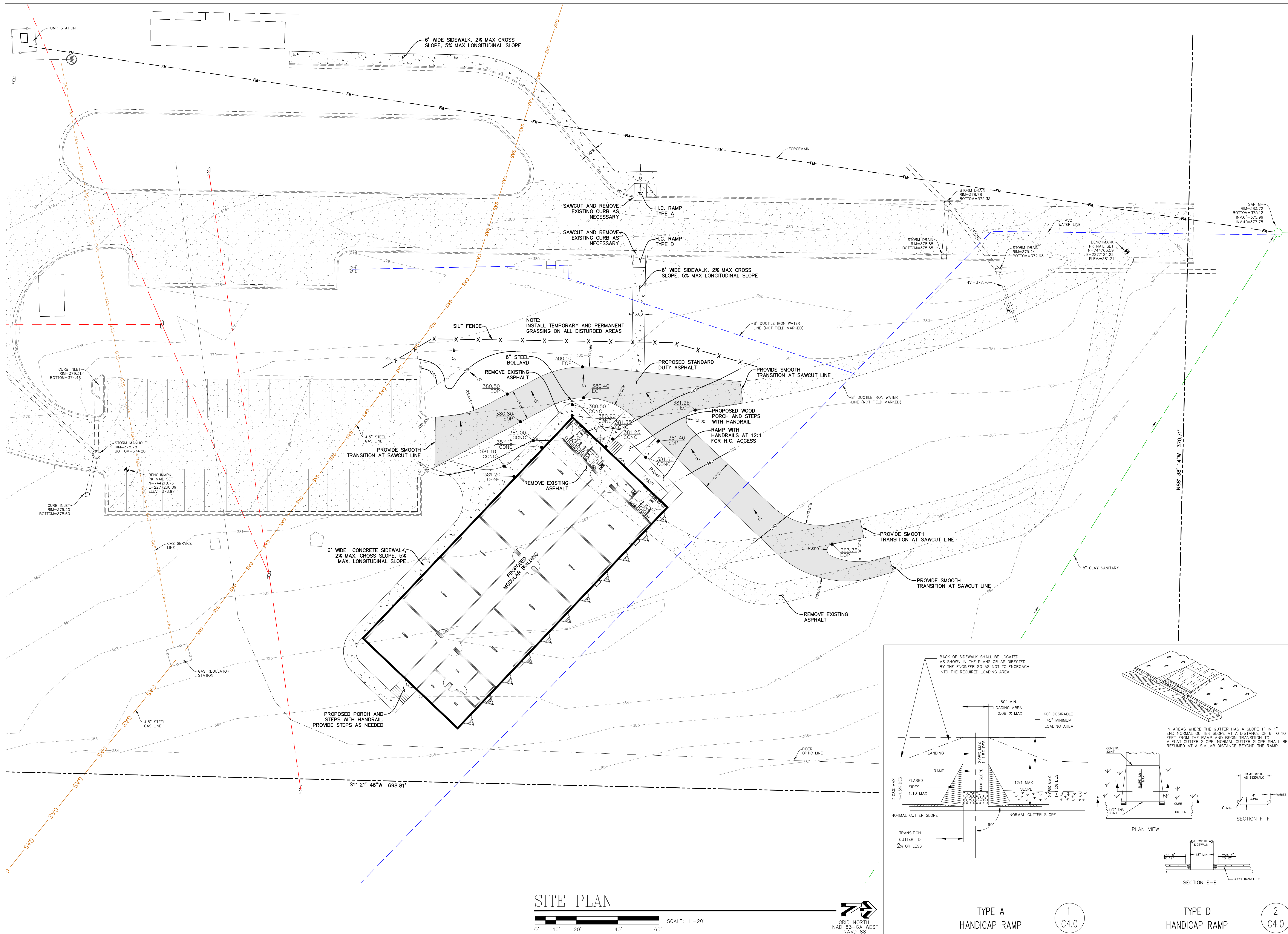

SITE PLAN

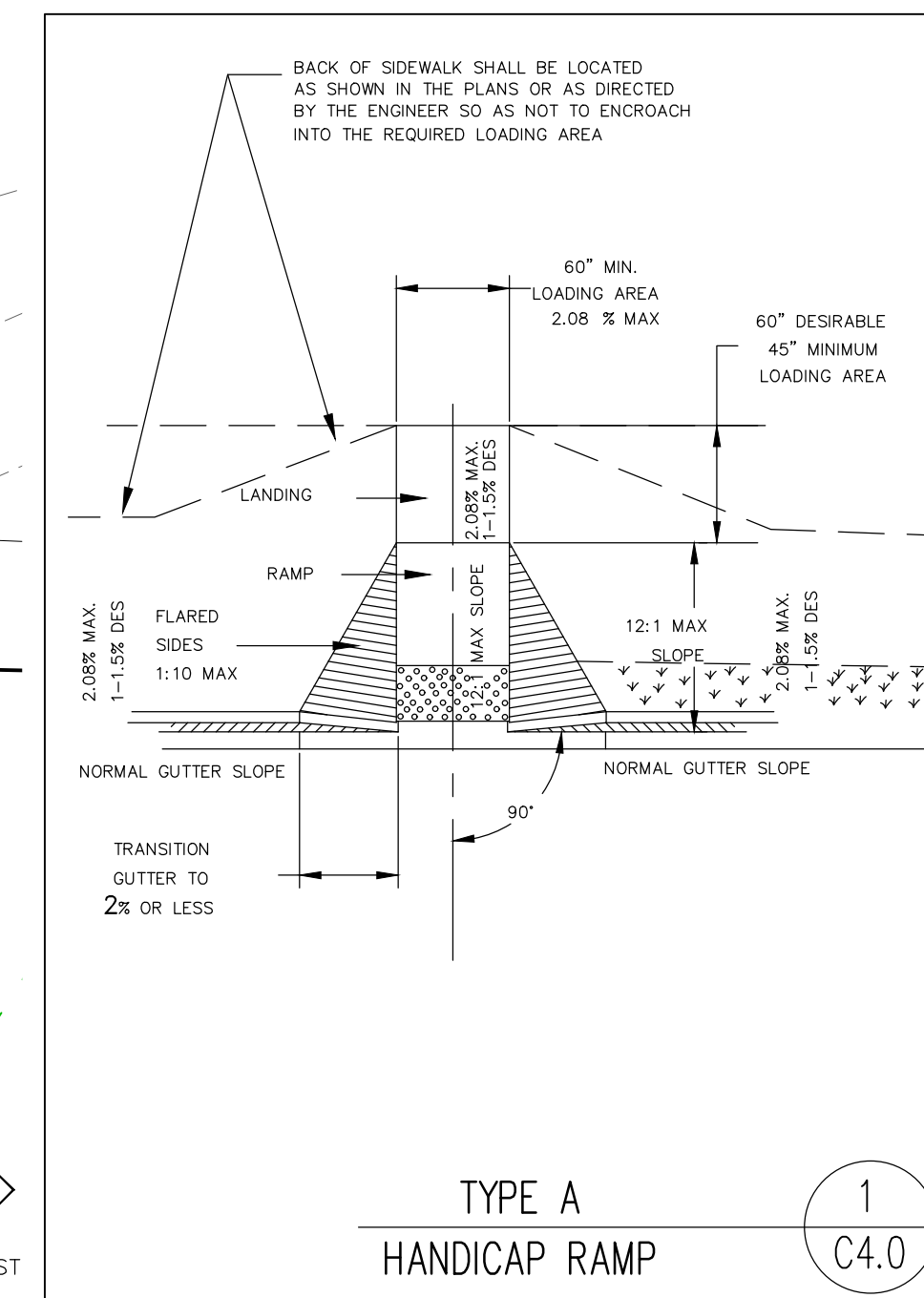
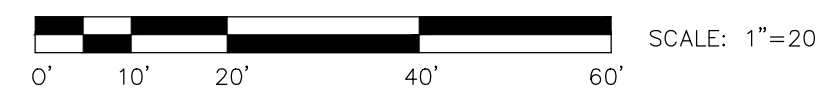

**TYPE A
HANDICAP RAMP**

1
C4.0

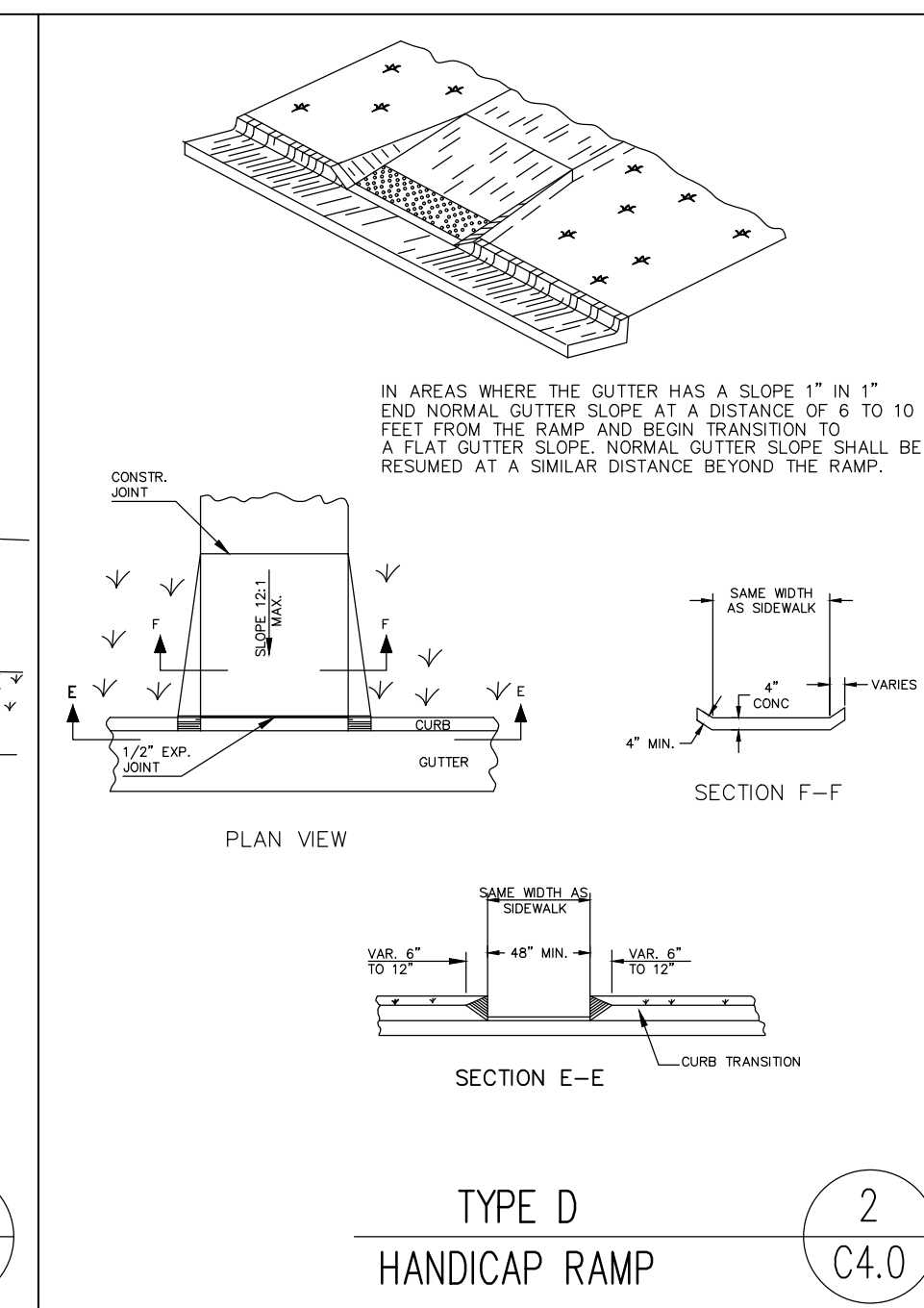

**TYPE D
HANDICAP RAMP**

2
C4.0

PROJECT:

**MODULAR BUILDING FOR
FURLOW CHARTER SCHOOL**

PART OF LAND LOT X
27th LAND DISTRICT
AMERICUS, SUMNER COUNTY, GEORGIA
DATE: NOVEMBER 28, 2022

REVISIONS

1	01/04/23	ADDED SIDEWALK
2		
3		
4		
5		
6		
7		
8		

FURLOW
CHARTER SCHOOL

63 VALLEY DRIVE
AMERICUS, GEORGIA 31709
(229) 931-8667

**HARRELL
JACKSON**
INC. CIVIL ENGINEERS

1021 HADLEY MEADOWS DRIVE
RALEIGH, NORTH CAROLINA
(919) 600-8399
www.tei-engineers.com

TEI
Threadcraft Engineering, Inc.

ENGINEER

ENGINEER

P.O. 7290
TIFTON, GEORGIA 31793
(229) 382-1700
www.harrelljacksoninc.com

OWNER

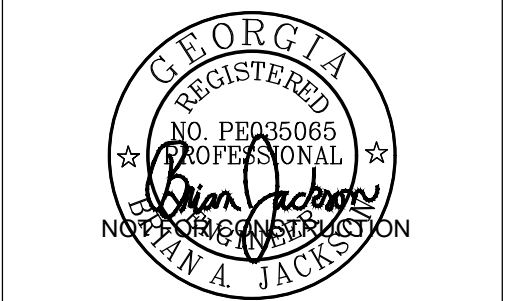

JN: 22023
SHEET NUMBER

C4.0

4 OF 6

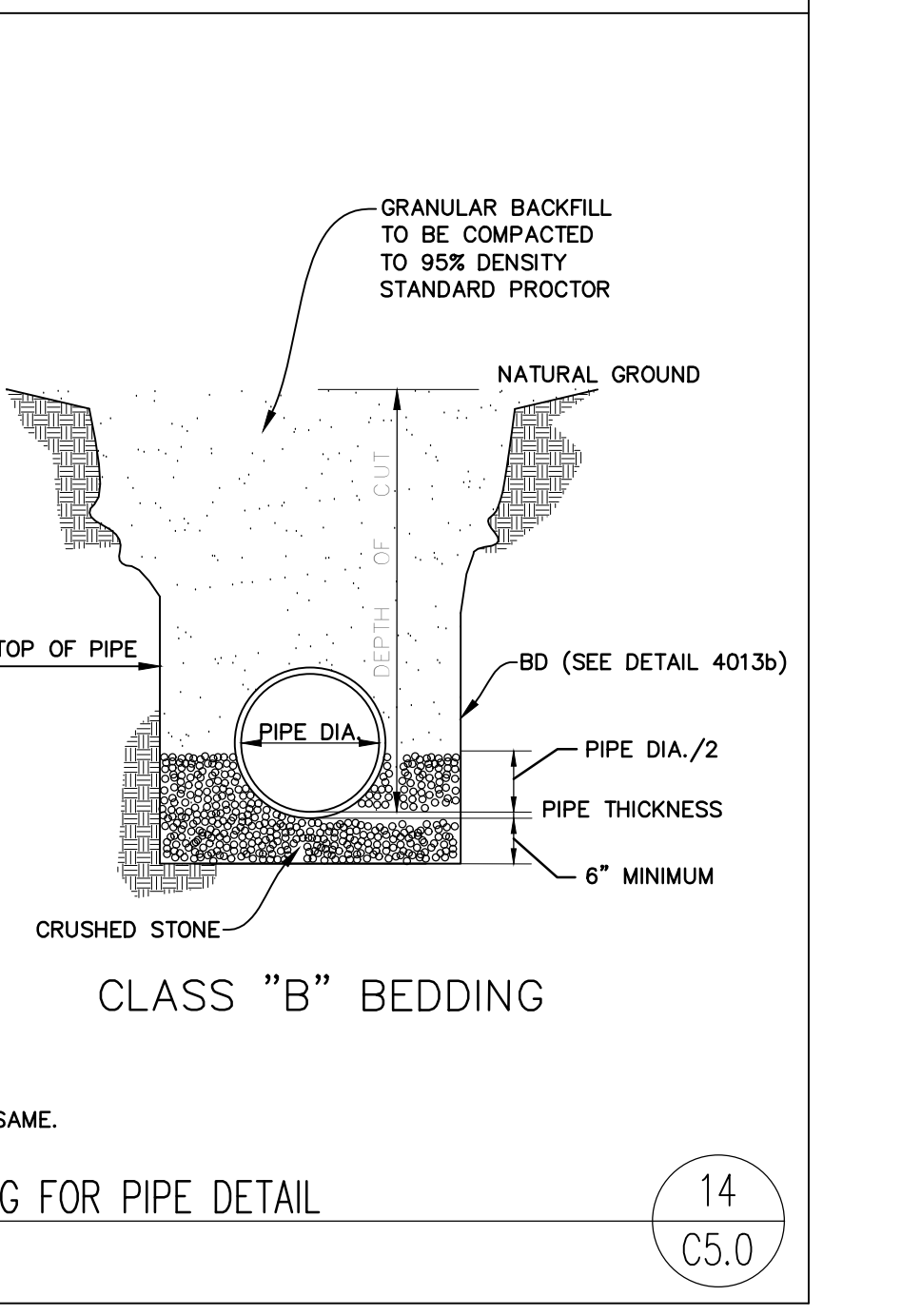
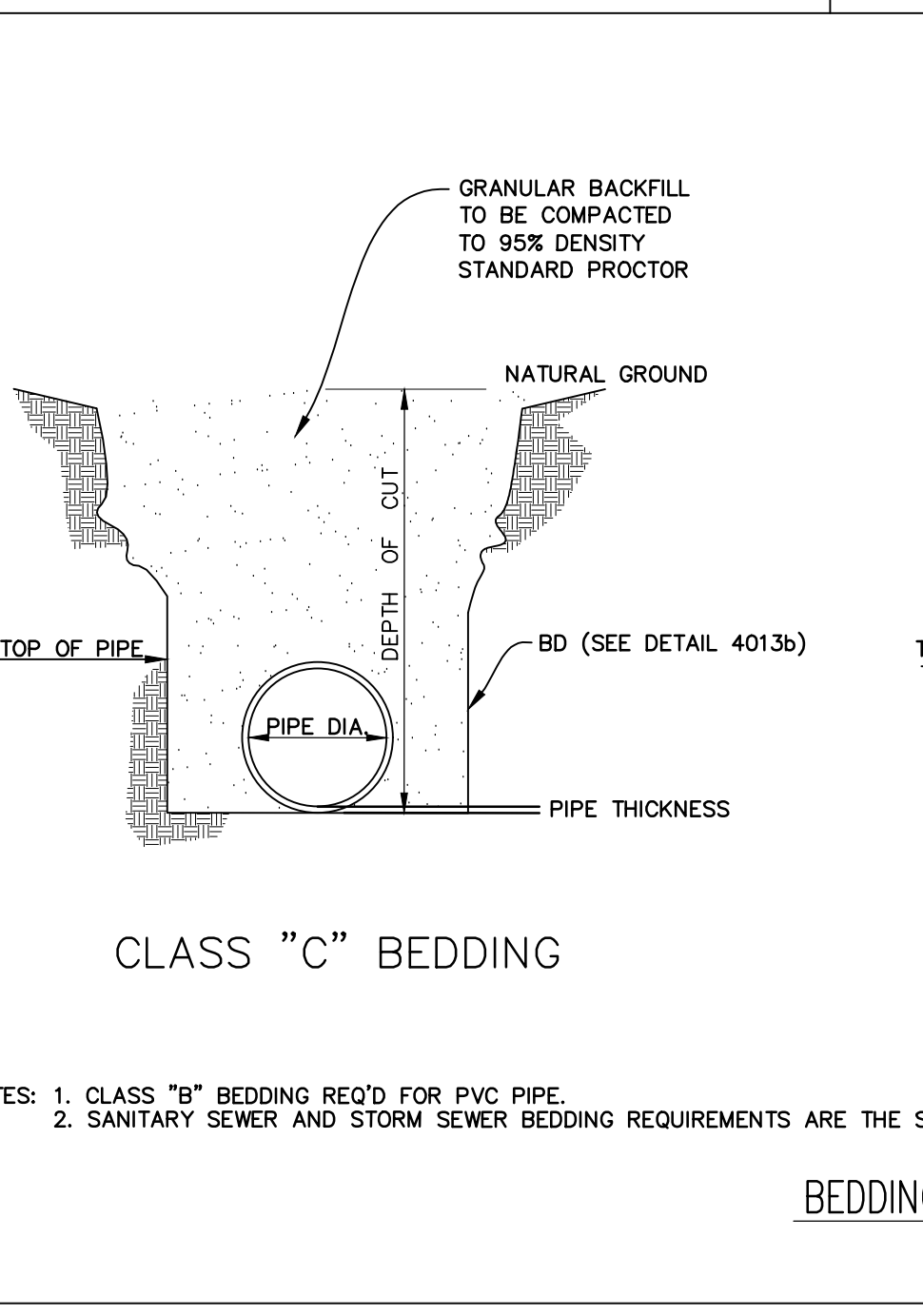
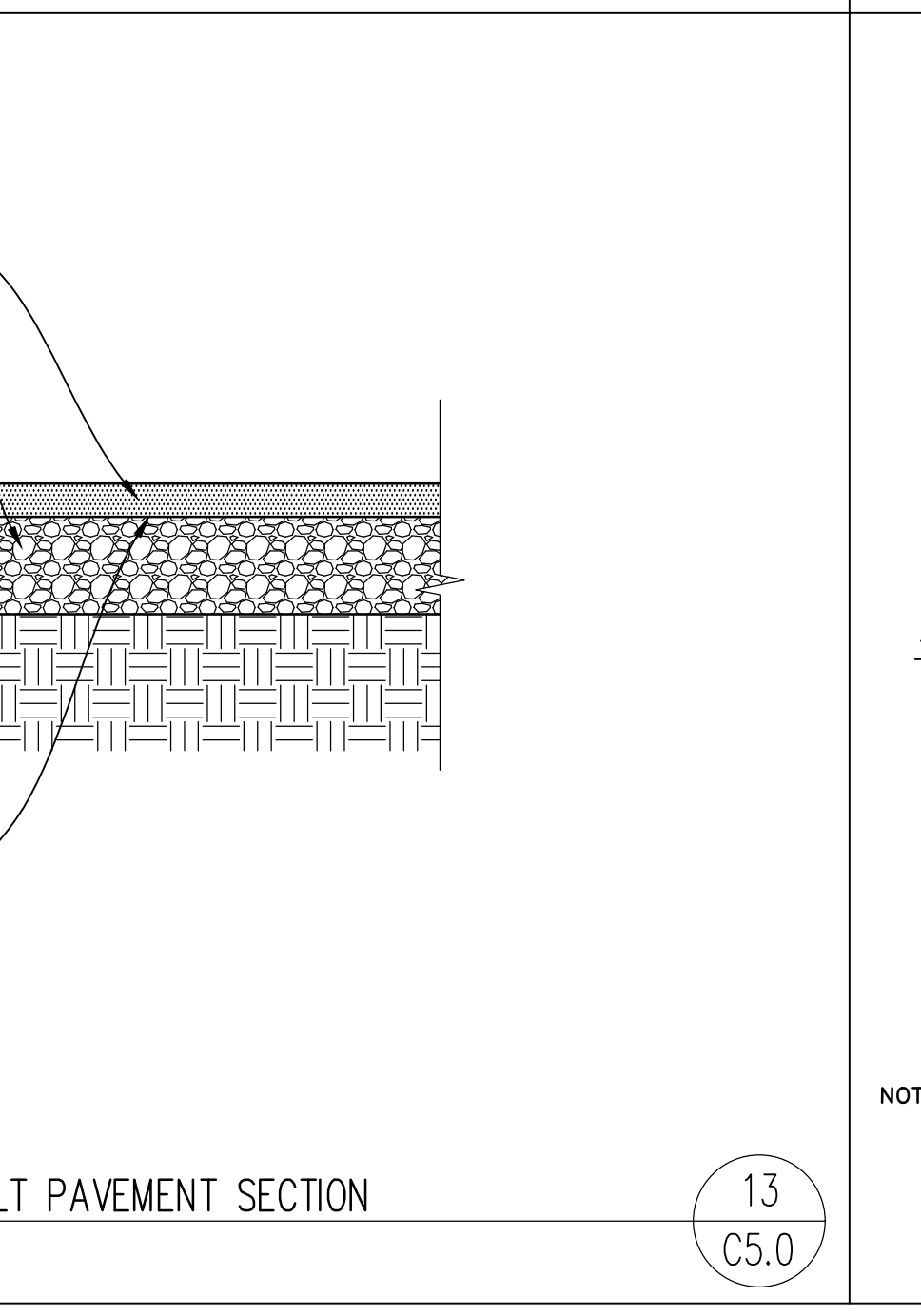
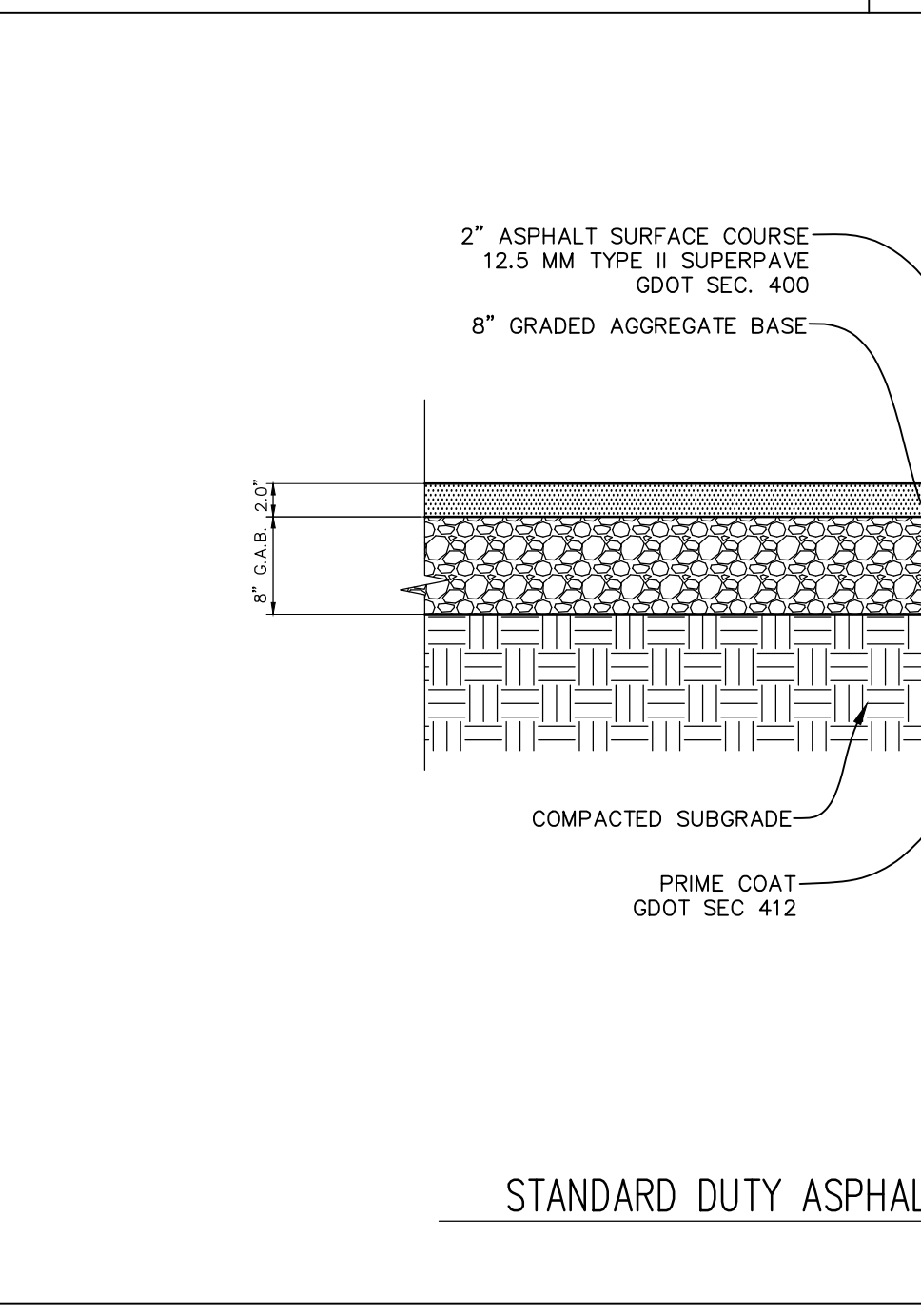
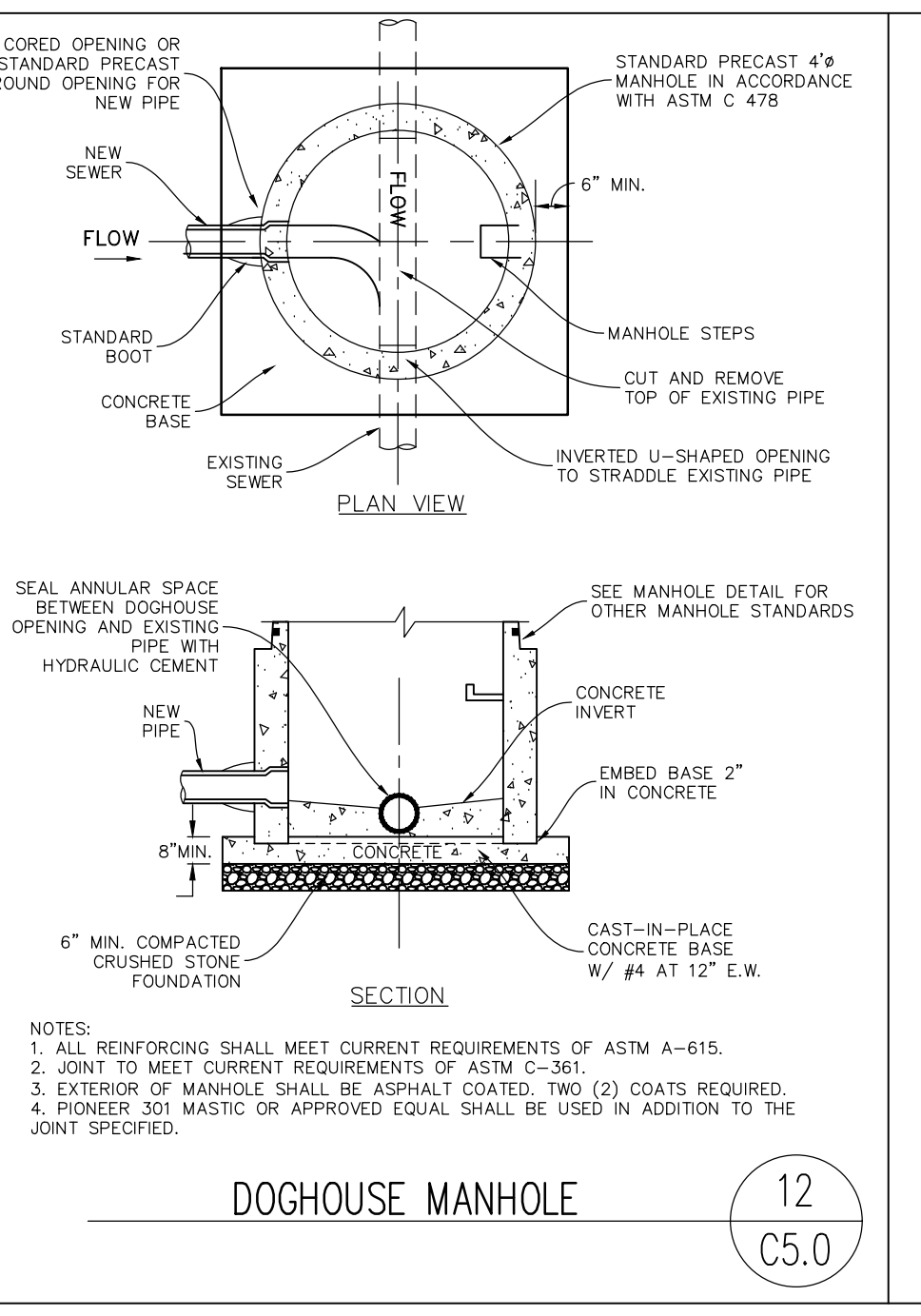
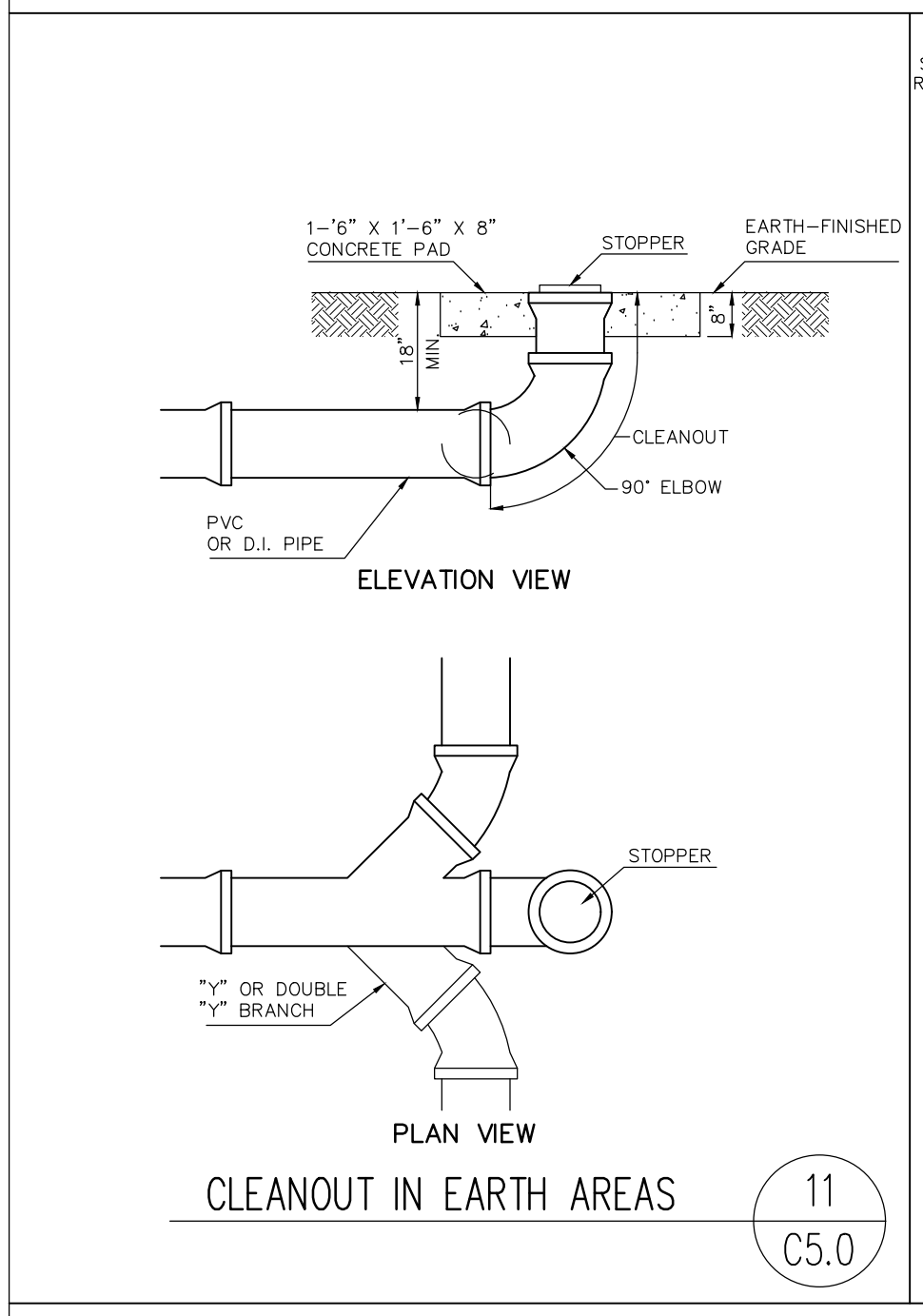
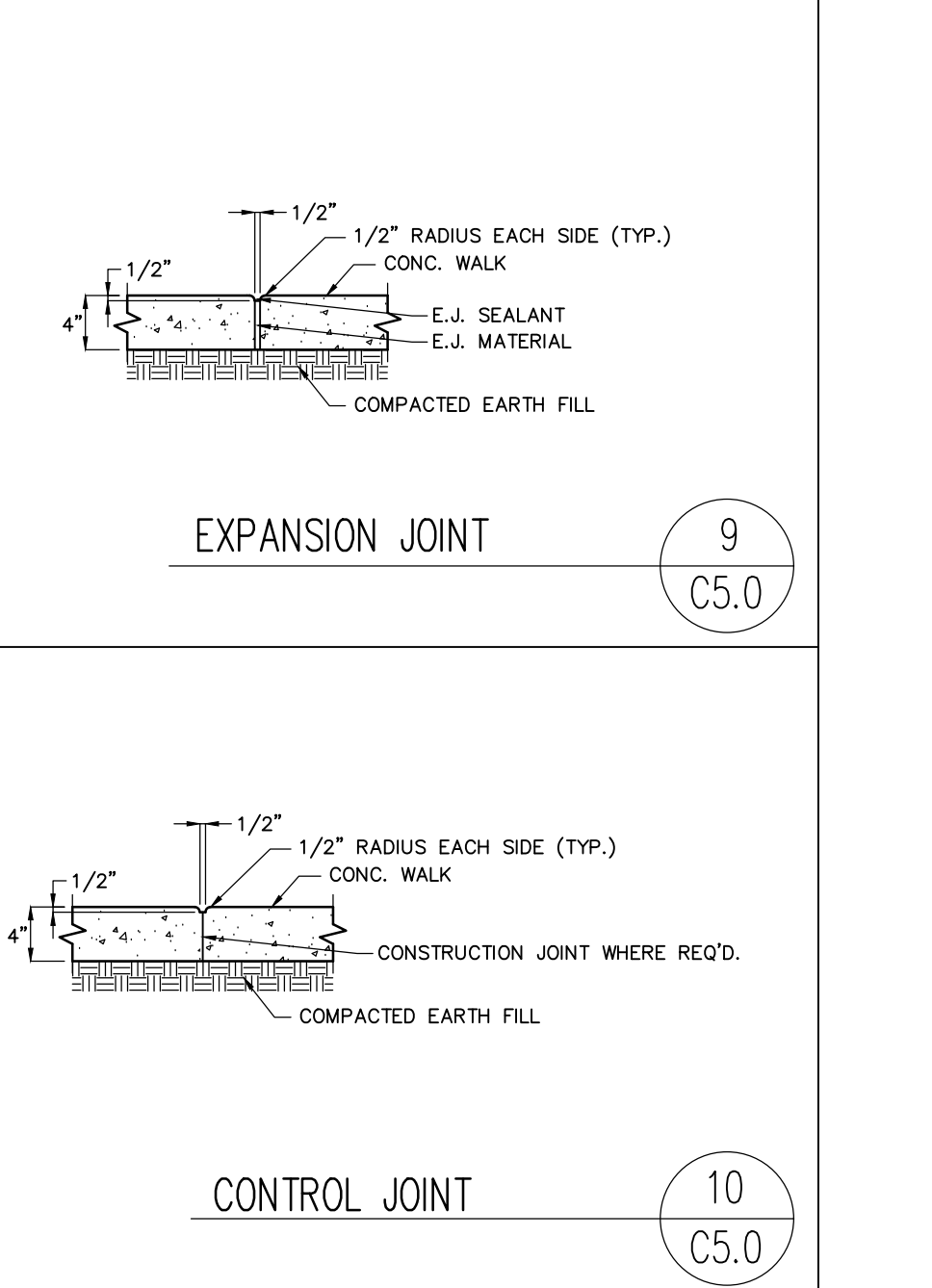
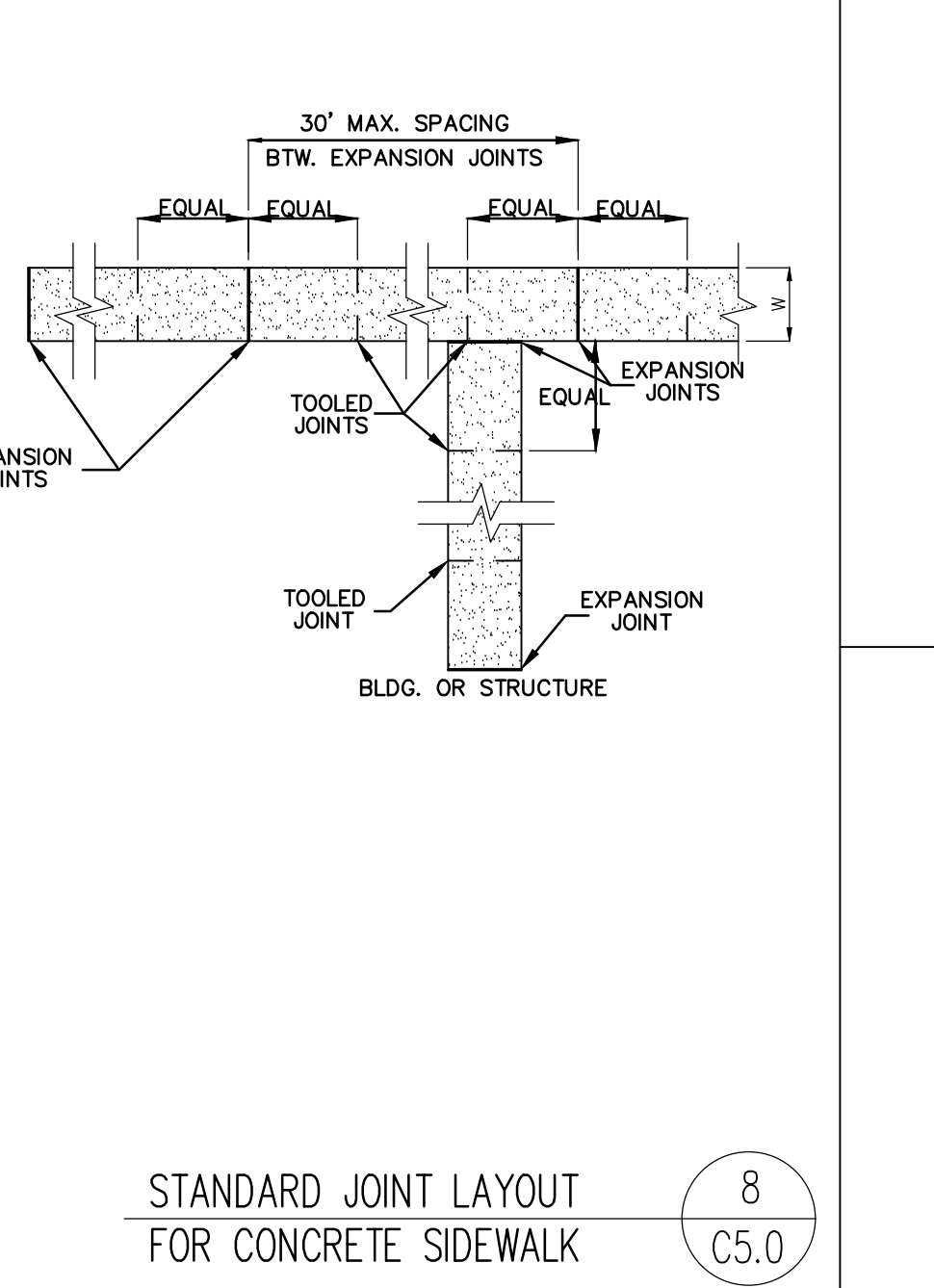
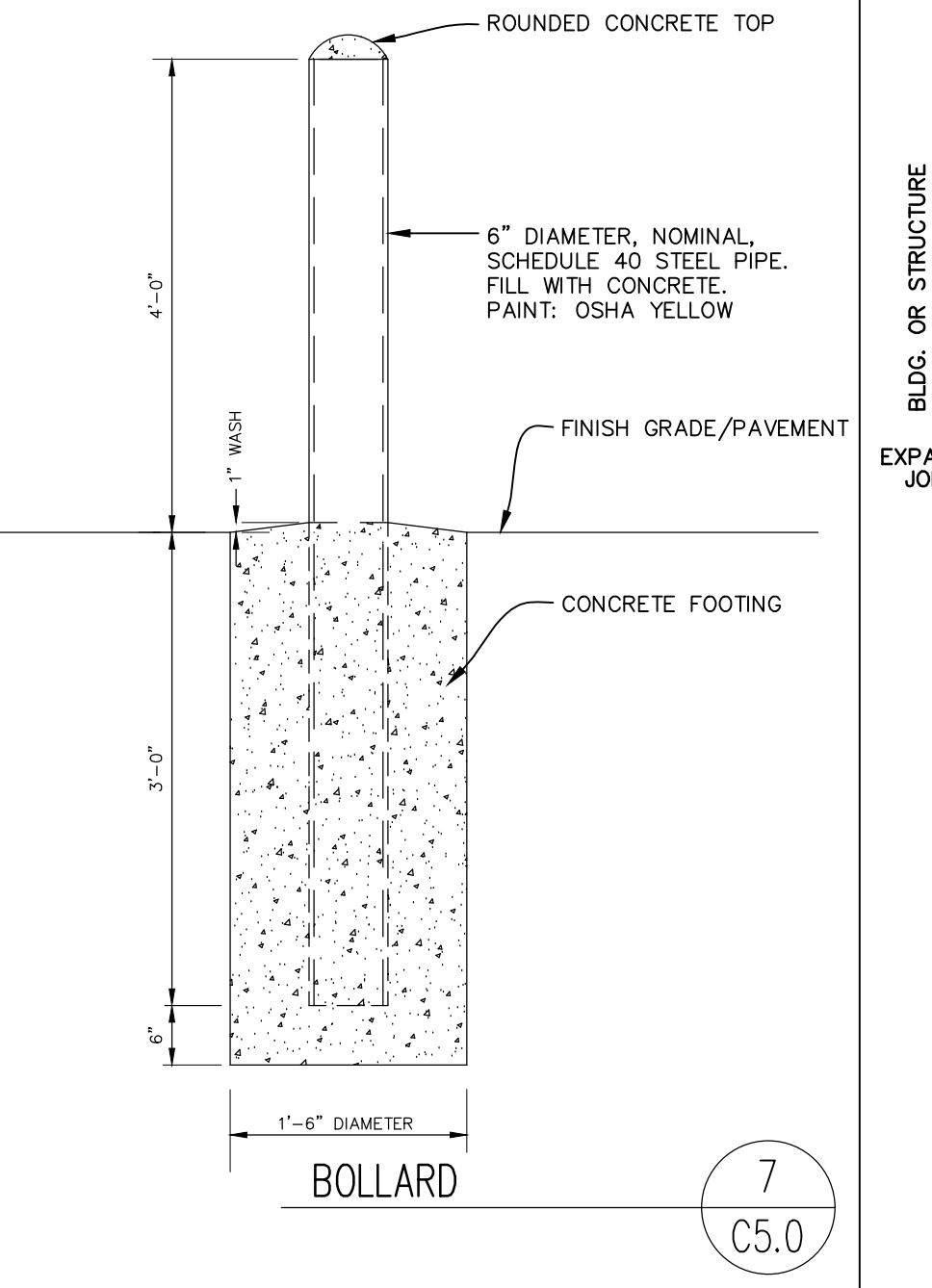
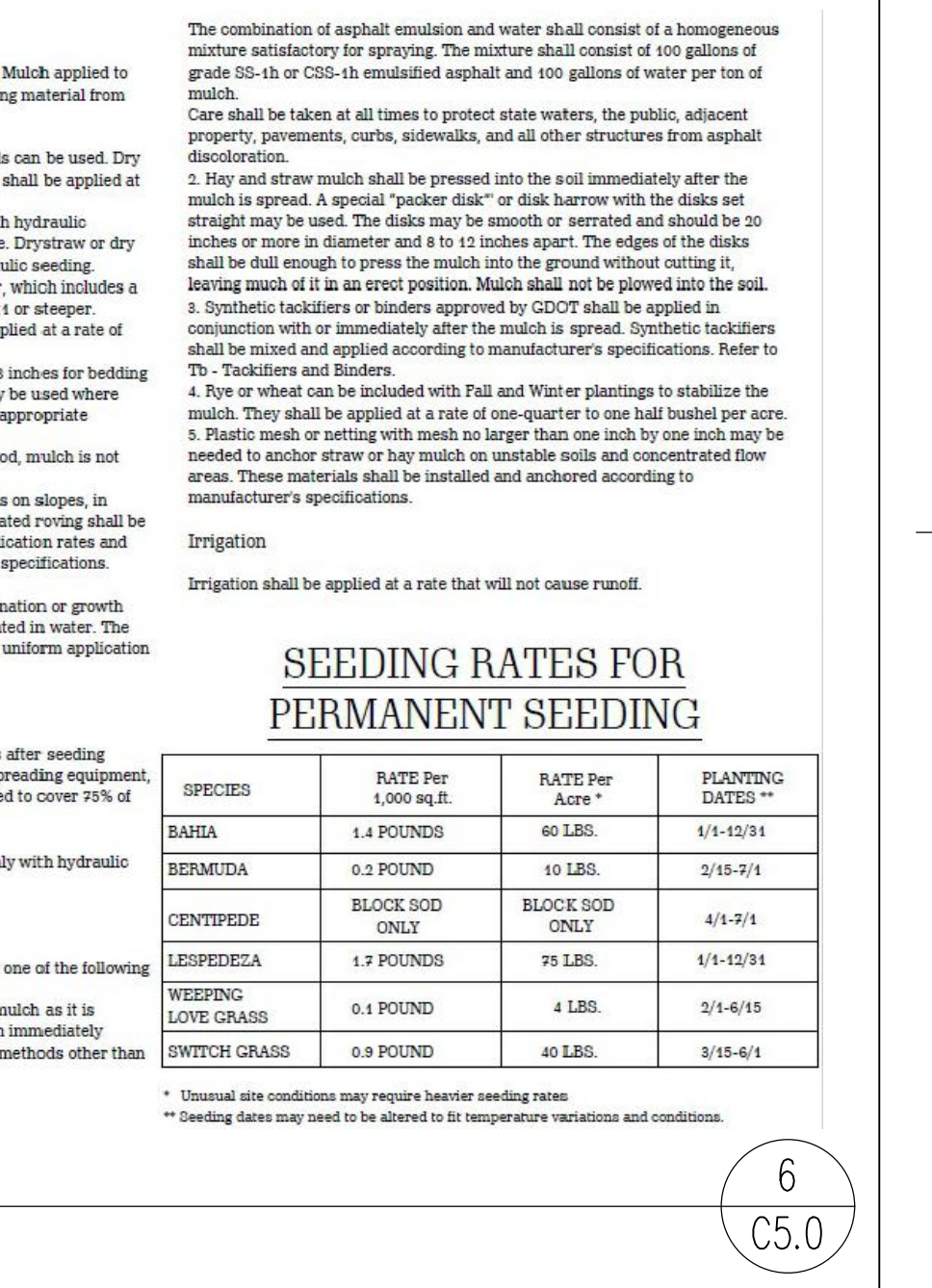
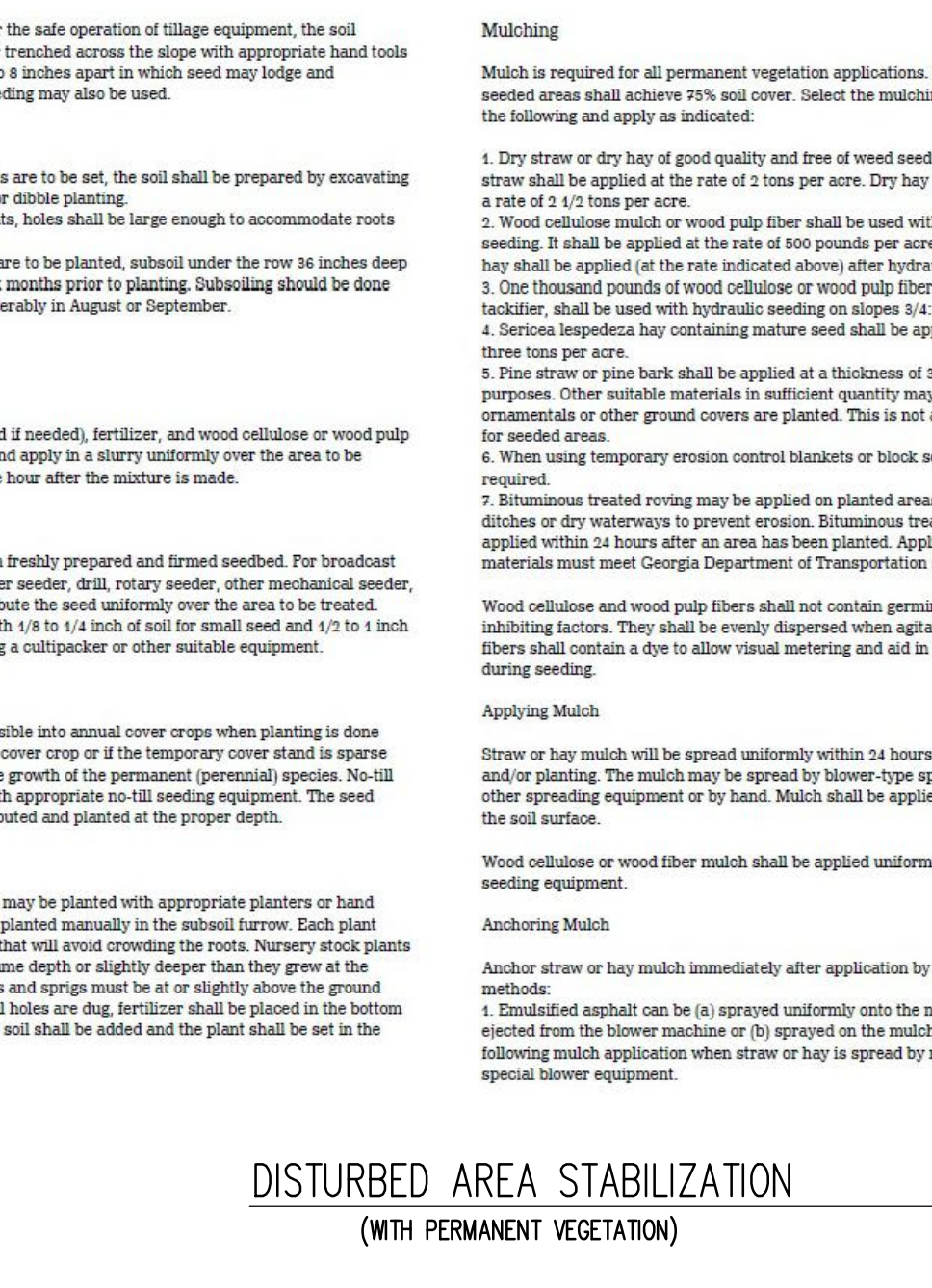
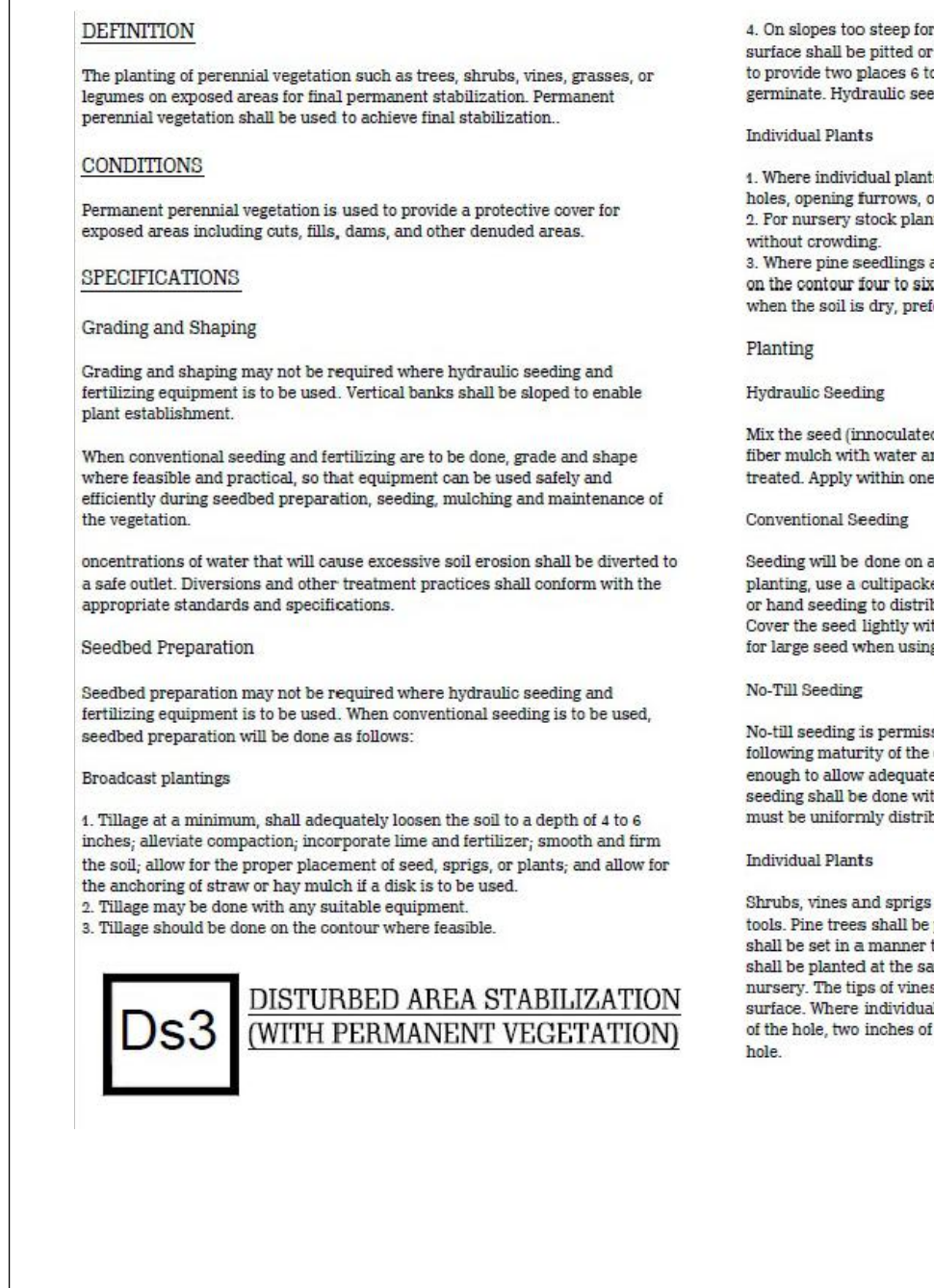
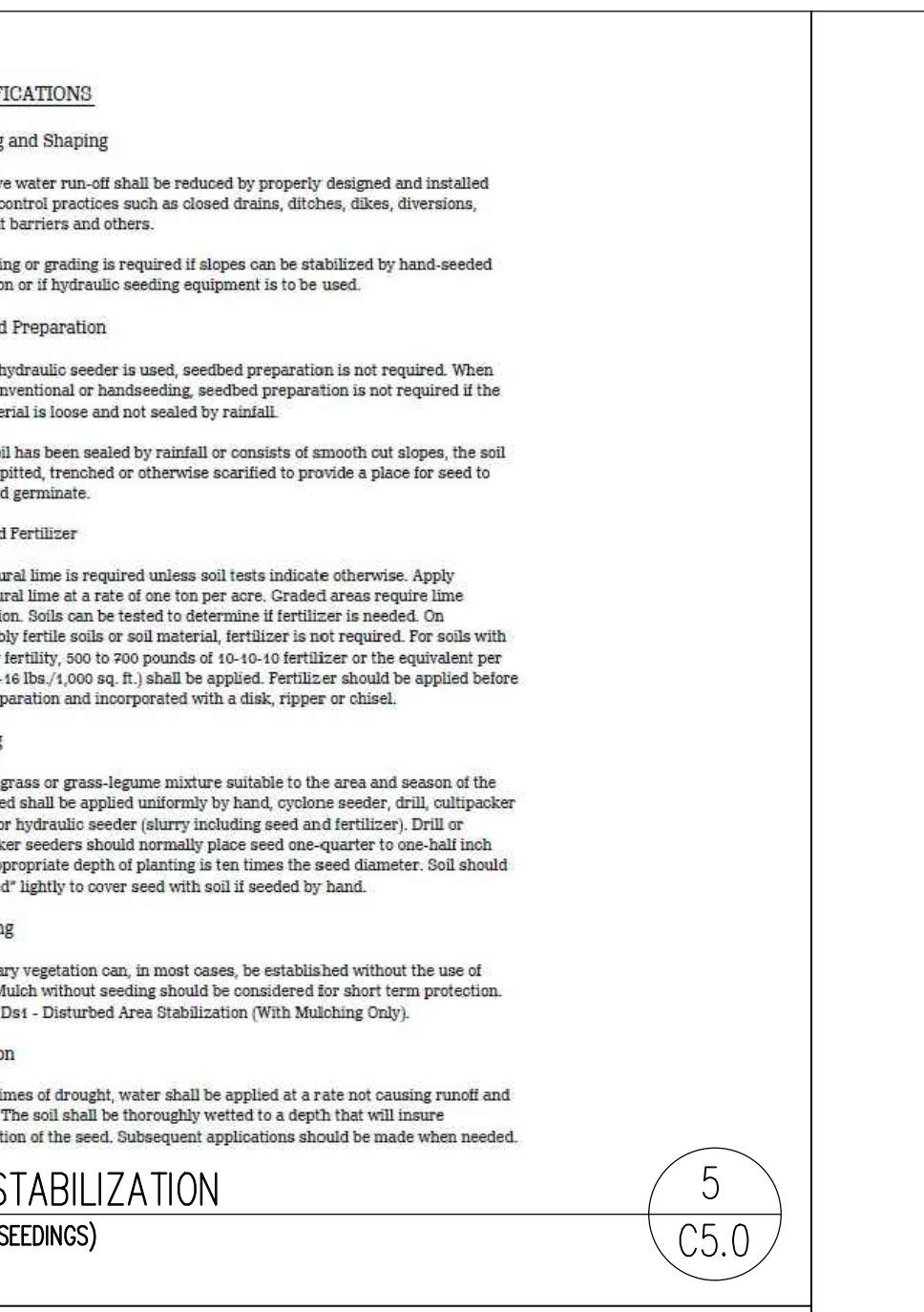
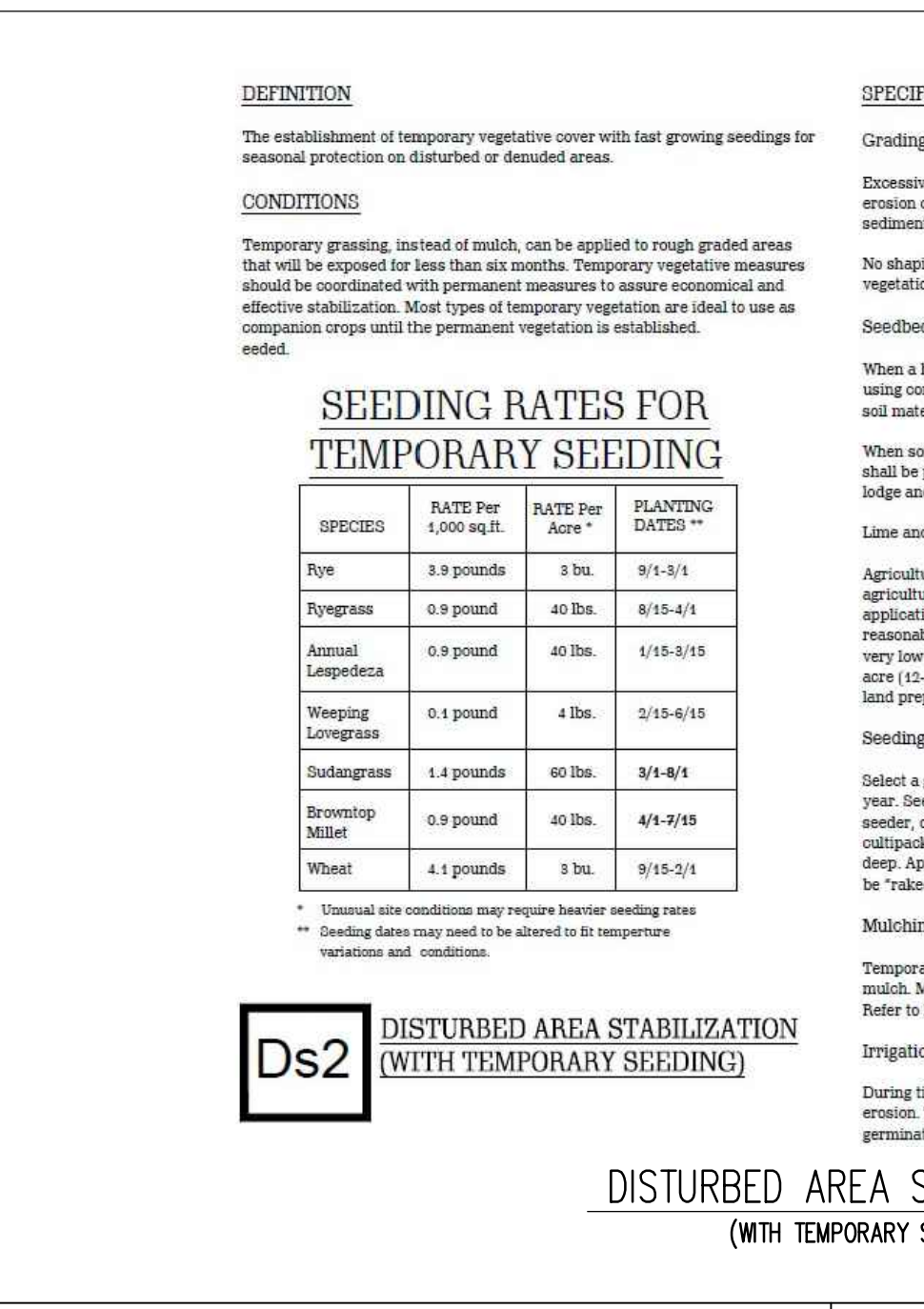
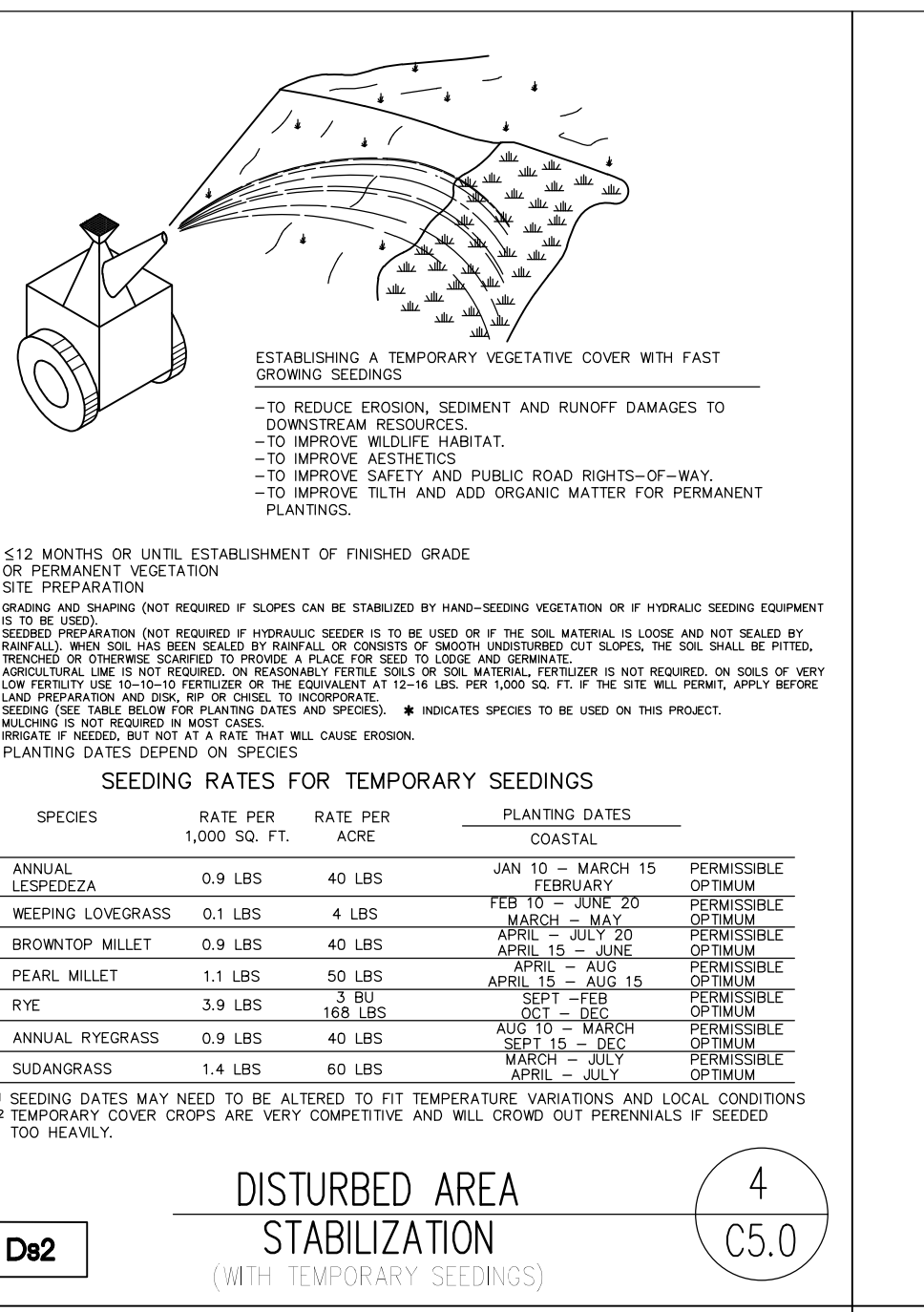
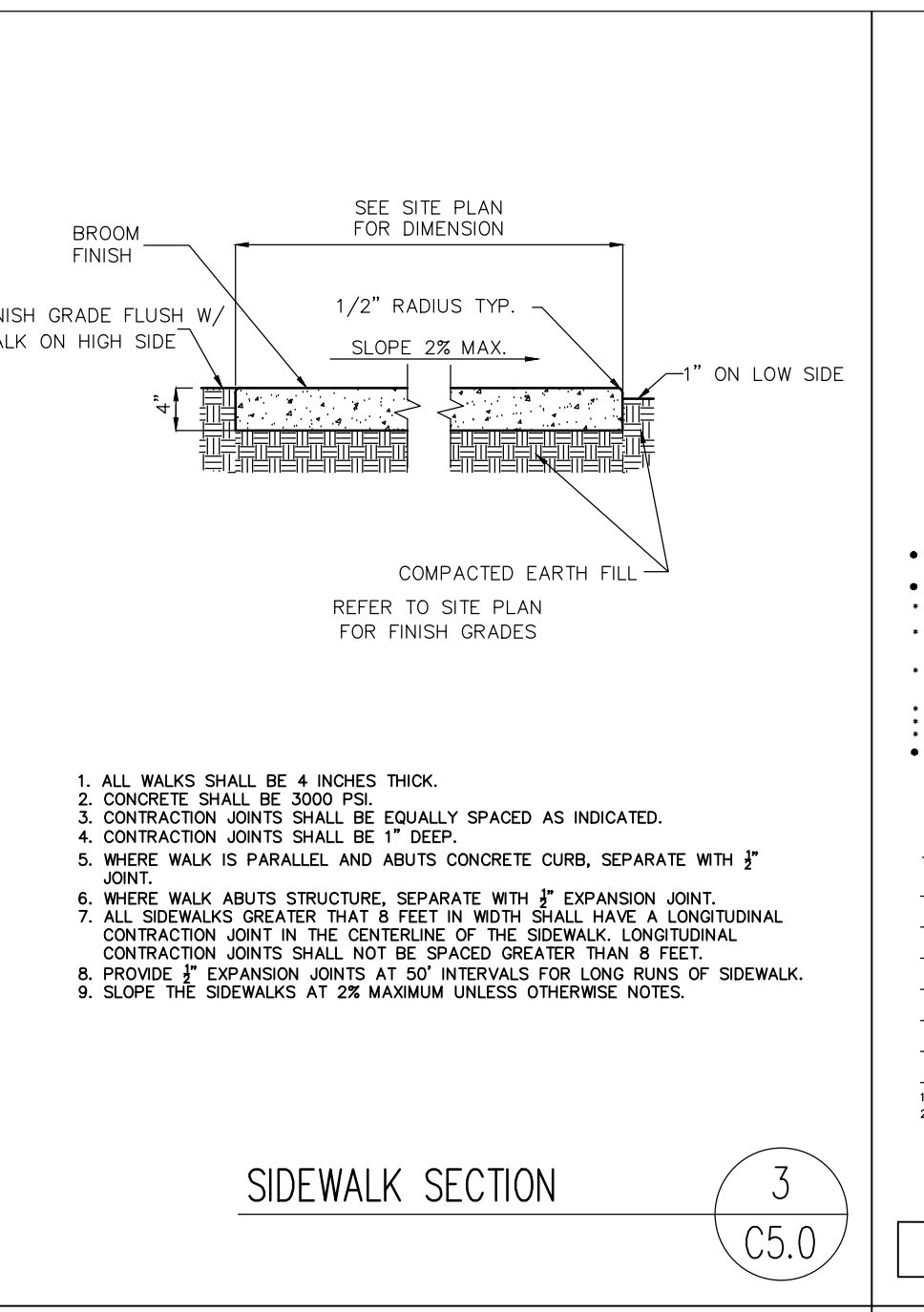
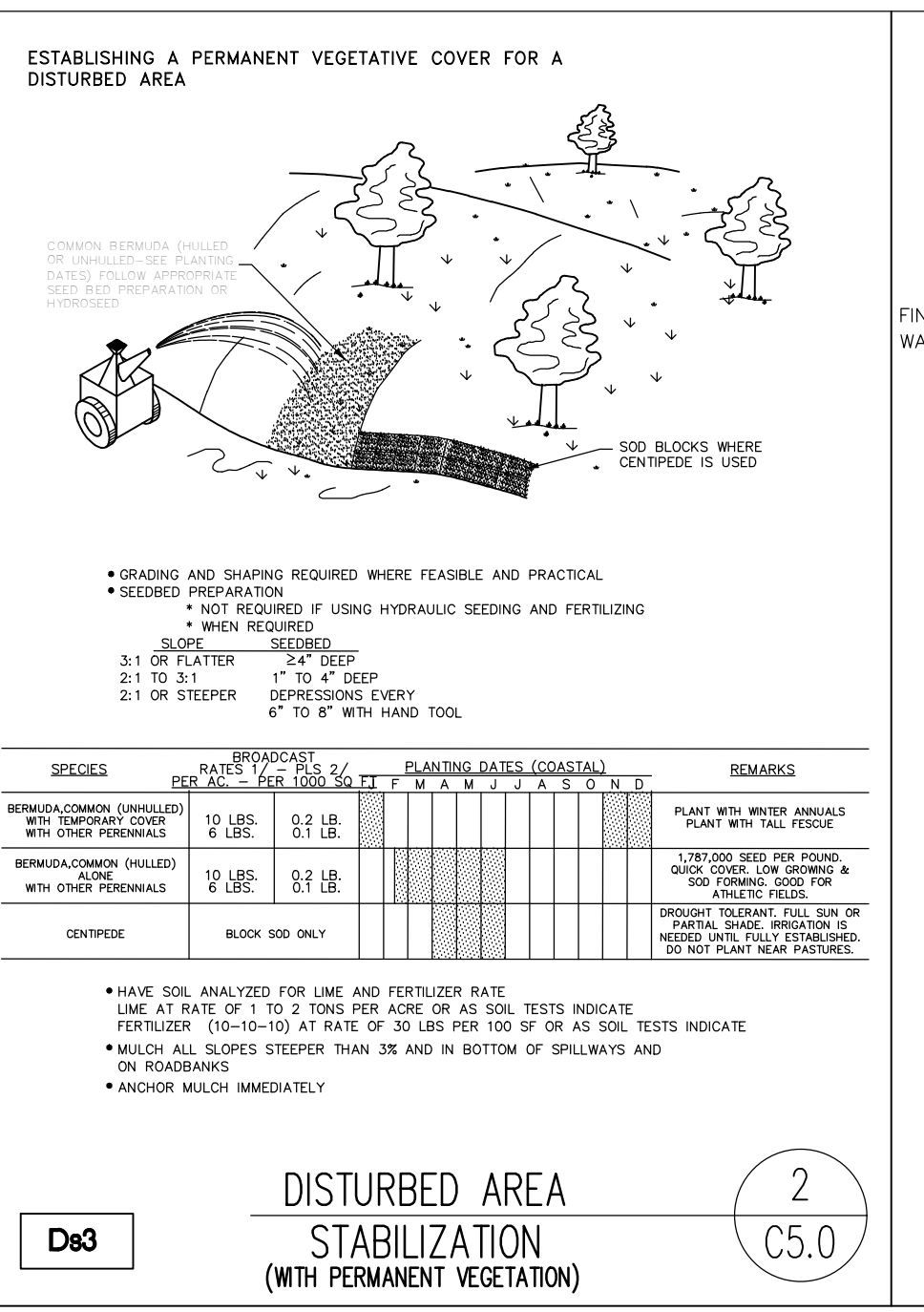
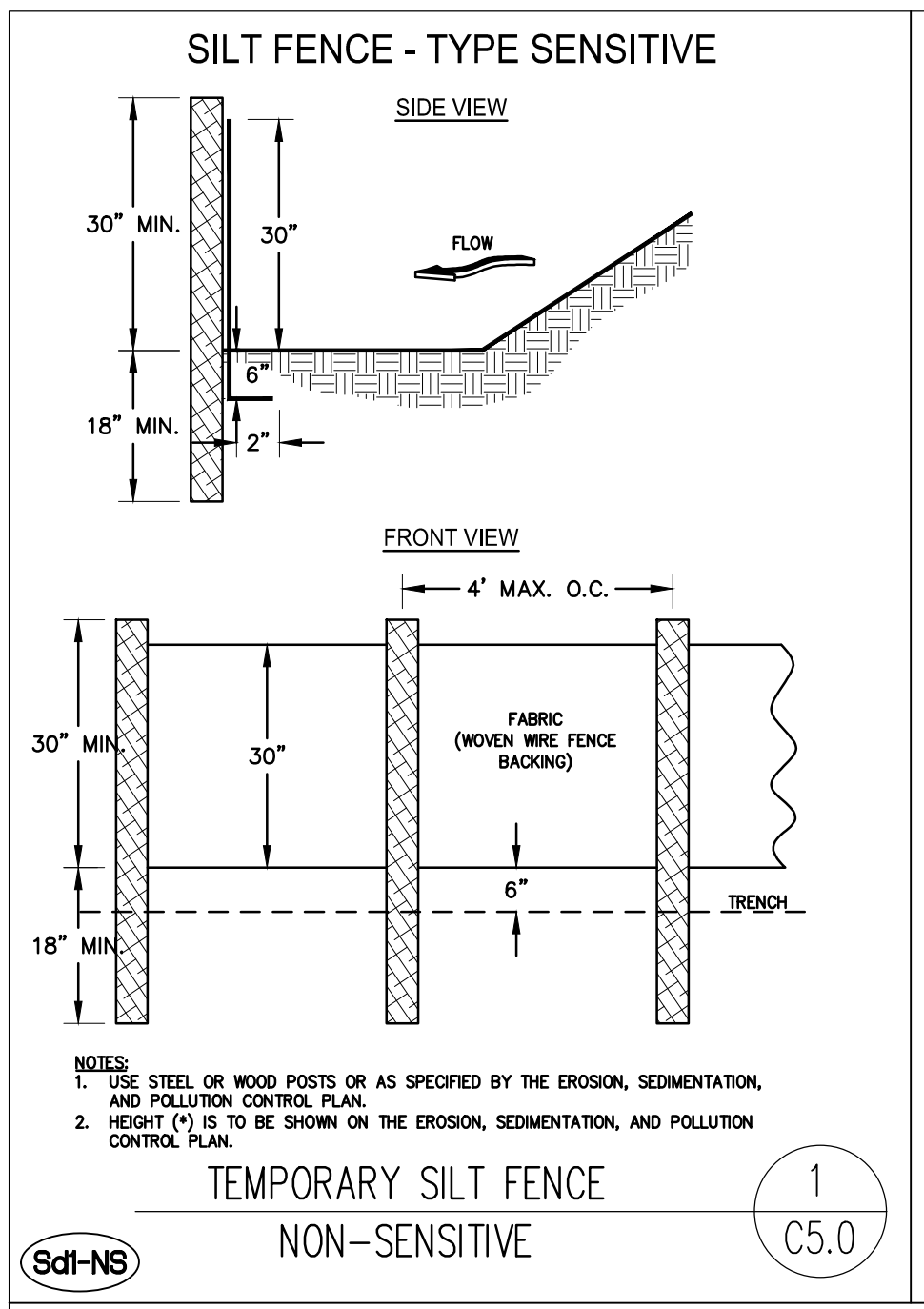

ENGINEER

TEI
Threadcraft Engineering, Inc.

1021 HADLEY MEADOWS DRIVE
RALEIGH, NORTH CAROLINA
(919) 600-8399
www.tei-engineers.com

ENGINEER

HARRELL
JACKSON
INC. CIVIL ENGINEERS

P.O. 7290
TIFTON, GEORGIA 31793
(229) 382-1700
www.harrelljacksoninc.com

OWNER

FURLOW
CHARTER SCHOOL

63 VALLEY DRIVE
AMERICUS, GEORGIA 31709
(229) 931-8667

REGISTERED PROFESSIONAL ENGINEER
E.J. JACKSON
No. 10030
SINCE 1982

REVISIONS

1	
2	
3	
4	
5	
6	
7	
8	

PROJECT:

MODULAR BUILDING FOR FURLOW CHARTER SCHOOL

PART OF LAND LOT X
27th LAND DISTRICT
AMERICUS, SUMNER COUNTY, GEORGIA
DATE: NOVEMBER 28, 2022

JN: 22023
SHEET NUMBER

C6.0

6 OF 6